ELECTRICAL POWER UTILIZATION

Subject Code : 10EE72

IA Marks : 25

No. of Lecture Hrs./ Week : 04

Exam Hours : 03

Total No. of Lecture Hrs. : 52

Exam Marks : 100

PART - A**UNIT – 1**

HEATING AND WELDING: Advantages and methods of electric of heating, resistance ovens, induction heating, dielectric heating, the arc furnace, heating of building. Electric welding, resistance and arc welding, control devices and welding equipment. 10 Hours

UNIT – 2

ELECTROLYTICPROCESS: Fundamental principles, extraction, refining of metals and electroplating. Factors affecting electro deposition process, power supply for electrolytic process.

06 Hours

UNIT - 3 & 4

ILLUMINATION: Laws of illumination, lighting calculation, factory lighting, flood lighting, street lighting, different types of lamps-incandescent, fluorescent, vapour, CFL and LED lamps and their working, comparison, Glare and its remedy. 12 Hours

PART – B**UNIT - 5, 6 & 7**

ELECTRIC TRACTION: Introduction, requirements of an ideal traction, systems of traction, speed time curve, tractive effort, co-efficient of adhesion, selection of traction motors, method of speed control, energy saving by series parallel control, ac traction equipment. AC series motor characteristics, regenerative braking, linear induction motor and their use. AC traction, diesel electric equipment, trains lighting system,

Specific energy, factors affecting specific energy consumption.

20 Hours

UNIT - 8

INTRODUCTION TO ELECTRIC AND HYBRID VEHICLES: Configuration and performance of electrical vehicles, traction motor characteristics, tractive effort, transmission requirement, vehicle performance and energy consumption. 6 Hours

TEXT BOOKS:

1. Utilization Of Electric Energy, E Openshaw Taylor, 12th Impression, 2009, Universities Press. 2. Modern Electric, Hybrid Electric and Fuel Cell Vehicles, Mehrdad, Ehsani, Yimin Gao, Sebastien. E. Gay, Ali Emadi- CRC Press.

REFERENCE BOOKS:

1. A Course in Electrical Power, Soni Gupta and Bhatnager-Dhanapat Rai & sons.
3. Electrical Power, Dr. S.L.Uppal, Khanna Publications

Sl.no	Contents	Page number
1	Unit-1: Heating And Welding	4 to 73
	Advantages	
	Resistance ovens	
	Induction heating	
	Dielectric heating,	
	The arc furnace	
	Heating of building	
	Electric welding	
	Resistance and arc welding	
	Control devices and welding equipment	
2	Unit-2 : Electrolytic Process	74 to 83
	Defination	
	Fundamental Principle	
	Extraction	
	Refining of metals	
	Electrodeposition	
	Power supply for electrolytic process	
3	Unit-3 & 4 : Illumination	84 to 113
	Laws of illumination	
	Lighting calculation	
	Factory lighting, flood lighting, street lighting	
	Different types of lamps-incandescent, fluorescent, vapor, CFL and LED lamps and their working	
	Glare and its remedy	
	Comparison	
4	Unit-5,6 &7:Electric Traction	114 to 158
	Introduction	
	Requirements of an ideal traction	
	Systems of traction	
	Speed time curve	
	Tractive effort	
	Co-efficient of adhesion, selection of traction motors	
	Method of speed control	
	Saving by series parallel control, ac traction equipment	
	AC series motor characteristics, regenerative braking	
	Linear induction motor and their use	
	AC traction, diesel electric equipment, trains lighting system	
	Specific energy	

	Factors affecting specific energy consumption	
5	Unit-8: introduction to electric and hybrid vehicles	159 to 171
	Configuration and performance of electrical vehicles	
	Traction motor characteristics	
	Tractive effort	
	Transmission requirement	
	Vehicle performance and energy consumption	

PART A

UNIT-1

HEATING AND WELDING:

Introduction

Electric heating is extensively used both for domestic and industrial applications. Domestic applications include (i) room heaters (ii) immersion heaters for water heating (iii) hot plates for cooking (iv) electric kettles (v) electric irons (vi) pop-corn plants (vii) electric ovens for bakeries and (viii) electric toasters etc. Industrial applications of electric heating include (i) melting of metals (ii) heat treatment of metals like annealing, tempering, soldering and brazing etc. (iii) moulding of glass (iv) baking of insulators (v) enameling of copper wires etc.

Advantages of Electric Heating

As compared to other methods of heating using gas, coal and fire etc., electric heating is far superior for the following reasons:

- (i) Cleanliness. Since neither dust nor ash is produced in electric heating, it is a clean system of heating requiring minimum cost of cleaning. Moreover, the material to be heated does not get contaminated.
- (ii) No Pollution. Since no flue gases are produced in electric heating, no provision has to be made for their exit.
- (iii) Economical. Electric heating is economical because electric furnaces are cheaper in their initial cost as well as maintenance cost since they do not require big space for installation or for storage of coal and wood. Moreover, there is no need to construct any chimney or to provide extra heat installation.
- (iv) Ease of Control. It is easy to control and regulate the temperature of an electric furnace with the help of manual or automatic devices. Temperature can be controlled within $\pm 5^{\circ}\text{C}$ which is not possible in any other form of heating.

- (v) **Special Heating Requirement.** Special heating requirements such as uniform heating of a material or heating one particular portion of the job without affecting its other parts or heating with no oxidation can be met only by electric heating.
- (vi) **Higher Efficiency.** Heat produced electrically does not go away waste through the chimney and other by-products. Consequently, most of the heat produced is utilised for heating the material itself. Hence, electric heating has higher efficiency as compared to other types of heating.
- (vii) **Better Working Conditions.** Since electric heating produces no irritating noises and also the radiation losses are low, it results in low ambient temperature. Hence, working with electric furnaces is convenient and cool.
- (viii) **Heating of Bad Conductors.** Bad conductors of heat and electricity like wood, plastic and bakery items can be uniformly and suitably heated with dielectric heating process.
- (ix) **Safety.** Electric heating is quite safe because it responds quickly to the controlled signals. (x) **Lower Attention and Maintenance Cost.** Electric heating equipment generally will not require much attention and supervision and their maintenance cost is almost negligible. Hence, labour charges are negligibly small as compared to other forms of heating.

Different Methods of Heat Transfer

The different methods by which heat is transferred from a hot body to a cold body are as under:

1. Conduction

In this mode of heat transfer, one molecule of the body gets heated and transfers some of the heat to the adjacent molecule and so on. There is a temperature gradient between the two ends of the body being heated.

Consider a solid material of cross-section A sq.m. and thickness x metre as shown in Fig. 1.1

If T_1 and T_2 are the temperatures of the two sides of the slab in $^{\circ}K$, then heat conducted between the two opposite faces in time t seconds is given by:

$$H = \frac{KA(T_1 - T_2)t}{x}$$

Where K is thermal conductivity of the material

2. Convection

In this process, heat is transferred by the flow of hot and cold air currents. This process is applied in the heating of water by immersion heater or heating of buildings. The quantity of heat absorbed by the body by convection process depends mainly on the temperature of the heating element above the surroundings and upon the size of the surface of the heater. It also depends, to some extent, on the position of the heater. The amount of heat dissipated is given by

$H = a(T_1 - T_2)$, where a and b are constants and T_1 and T_2 are the temperatures of the heating surface and the fluid in $^{\circ}K$ respectively.

In electric furnaces, heat transferred by convection is negligible

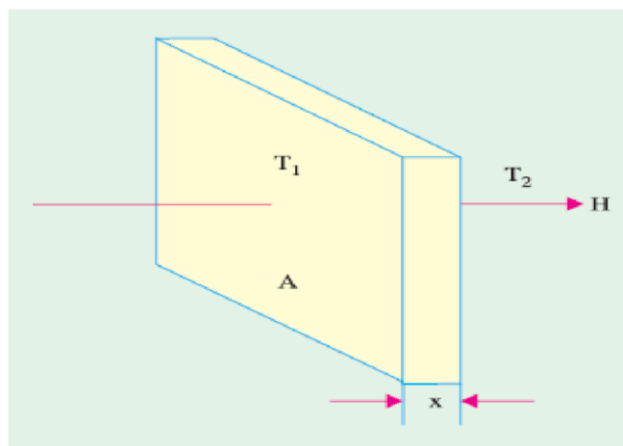

Fig1.1

It is the transfer of heat from a hot body to a cold body in a straight line without affecting the intervening medium. The rate of heat emission is given by Stefan’s law according to which Heat

$$H = 5.72 eK \left[\left(\frac{T_1}{100} \right)^4 - \left(\frac{T_2}{100} \right)^4 \right] \text{ W/m}^2$$

dissipated where K is radiating efficiency and e is known as emissivity of the heating element.

If d is the diameter of the heating wire and l its total length, then its surface area from which heat is radiated $= \pi d l$. If H is the power radiated per m^2 of the heating surface, then total power radiated as heat $= H \pi d l$. If P_{in} is the electrical power input to the heating element, then $P_{in} = \pi d l H$.

□

Methods of Electric Heating

Basically, heat is produced due to the circulation of current through a resistance. The current may circulate directly due to the application of potential difference or it may be due to induced eddy currents. Similarly, in magnetic materials, hysteresis losses are used to create heat. In dielectric heating, molecular friction is employed for heating the substance. An arc established between an electrode and the material to be heated can be made a source of heat. Bombarding the surface of material by high energy particles can be used to heat the body.



Different methods of producing heat for general industrial and domestic purposes may be classified below:

Resistance Heating

It is based on the I^2R effect. When current is passed through a resistance element I^2R loss takes place which produces heat. There are two methods of resistance heating.

(a) Direct Resistance Heating. In this method the material (or charge) to be heated is treated as a resistance and current is passed through it. The charge may be in the form of powder, small solid pieces or liquid. The two electrodes are inserted in the charge and connected to either a.c. or d.c. supply (Fig. 1.2). Obviously, two electrodes will be required in the case of d.c. or single-phase a.c. supply but there would be three electrodes in the case of 3-phase supply. When the charge is in the form of small pieces, a powder of high resistivity material is sprinkled over the surface of the charge to avoid direct short circuit.

Heat is produced when current passes through it. This method of heating has high efficiency because the heat is produced in the charge itself.

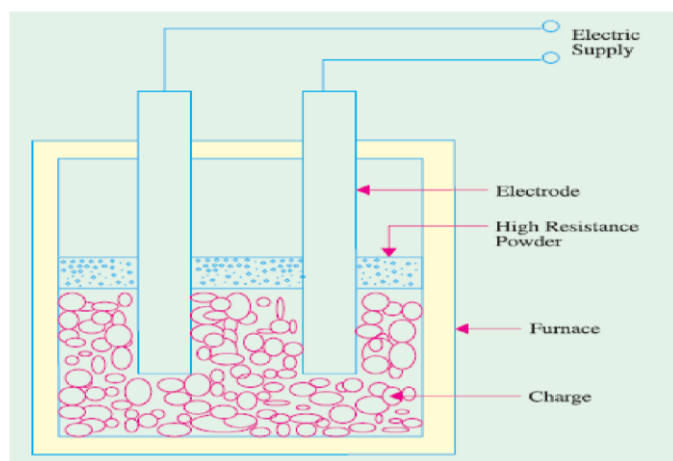
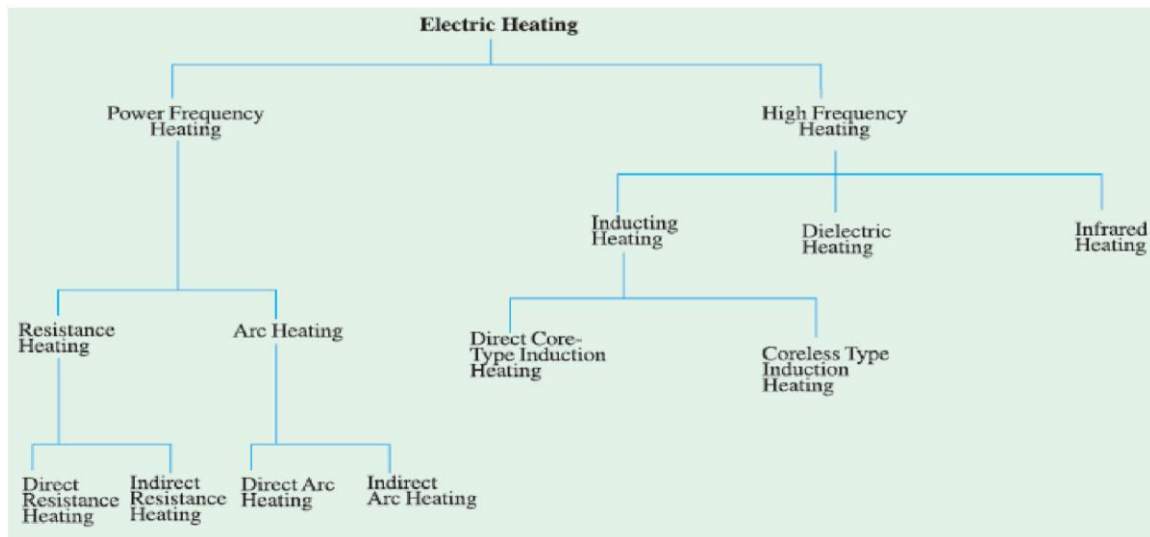

Fig1.2

Indirect Resistance

Heating. In this method of heating, electric current is passed through a resistance element which is placed in an electric oven. Heat produced is proportional to I^2R losses in the heating element. The heat so produced is delivered to the charge either by radiation or convection or by a combination of the two.

Sometimes, resistance is placed in a cylinder which is surrounded by the charge placed in the jacket as shown in the Fig. 1.3. This arrangement provides uniform temperature. Moreover, automatic temperature control can also be provided.

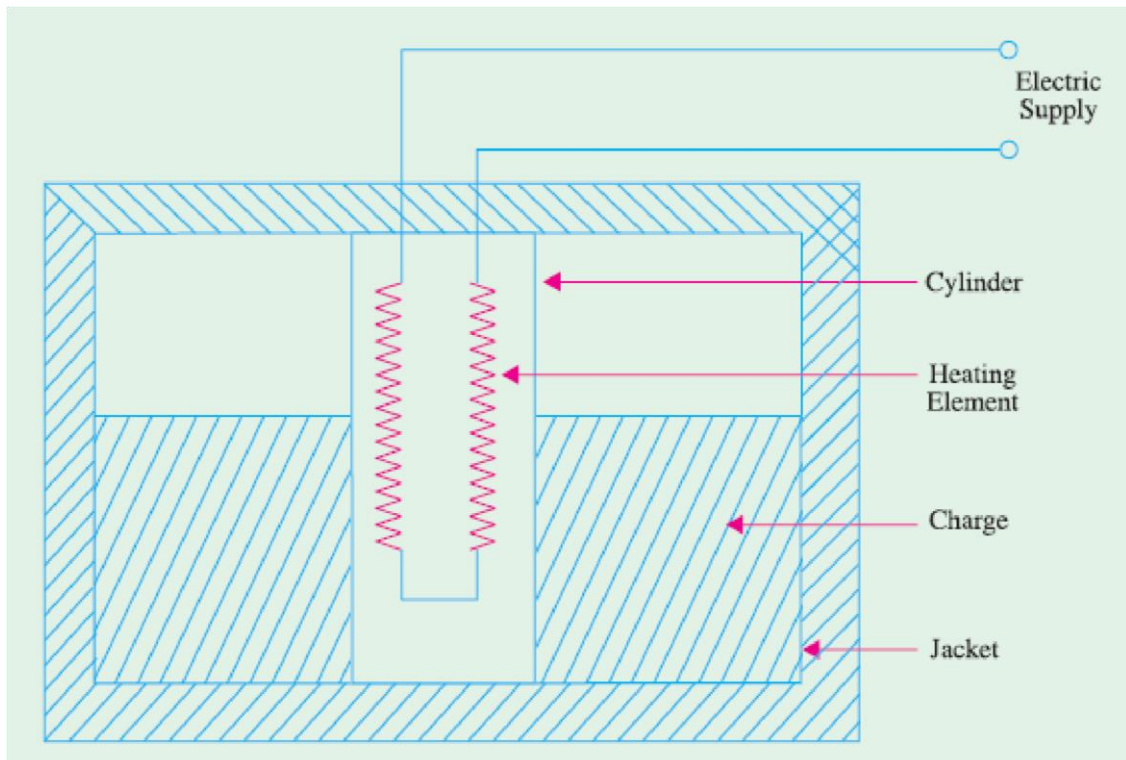

Fig1.3

Requirement of a Good Heating Element

Indirect resistance furnaces use many different types of heating elements for producing heat. A good heating element should have the following properties :

- (1) **High Specific Resistance.** When specific resistance of the material of the wire is high, only short length of it will be required for a particular resistance (and hence heat) or for the same length of the wire and the current, heat produced will be more.
- (2) **High Melting Temperature.** If the melting temperature of the heating element is high, it would be possible to obtain higher operating temperatures.
- (3) **Low Temperature Coefficient of Resistance.** In case the material has low temperature coefficient of resistance, there would be only small variations in its resistance over its normal range of temperature. Hence, the current drawn by the heating element when cold (*i.e.*, at start) would be practically the same when it is hot.
- (4) **Oxidising Temperature.** Oxidisation temperature of the heating element should be high in order to ensure longer life.

(5) **Positive Temperature Coefficient of Resistance.** If the temperature coefficient of the resistance of heating element is negative, its resistance will decrease with rise in temperature and it will draw more current which will produce more wattage and hence heat. With more heat, the resistance will decrease further resulting in instability of operation.

(6) **Ductile.** Since the material of the heating elements has to have convenient shapes and sizes, it should have high ductility and flexibility.

(7) **Mechanical Strength.** The material of the heating element should possess high mechanical strength of its own. Usually, different types of alloys are used to get different operating temperatures. For example maximum working temperature of *constantan* (45% Ni, 55% Cu) is 400°C, that of *nichrome* (50% Ni, 20% Cr) is 1150°C, that of *Kantha* (70% Fe, 25% Cr, 5% Al) is 1200°C and that of *silicon carbide* is 1450°C.

With the passage of time, every heating element breaks open and becomes unserviceable.

Some of the factors responsible for its failure are :

(1) Formation of hot spots which shine brighter during operation, (2) Oxidation (3) Corrosion (4) Mechanical failure

Resistance Furnaces or Ovens

These are suitably-insulated closed chambers with a provision for ventilation and are used for a wide variety of purposes including heat treatment of metals like annealing and hardening etc., stoving of enamelled wares, drying and baking of potteries, vulcanizing and hardening of synthetic materials and for commercial and domestic heating. Temperatures upto 1000°C can be obtained by using heating elements made of nickel, chromium and iron. Ovens using heating elements made of graphite can produce temperatures upto 3000°C. Heating elements may consist of circular wires or rectangular ribbons. The ovens are usually made of a metal framework having an internal lining of fire bricks. The heating element may be located on the top, bottom or sides of the oven. The nature of the insulating material is determined by the maximum temperature required in the oven.

An enclosure for charge which is heated by radiation or convection or both is called a *heating chamber*.

Temperature Control of Resistance Furnaces

The temperature of a resistance furnace can be changed by controlling the I^2R or V^2/R losses.

Following different methods are used for the above purpose :

(1) Intermittent Switching. In this case, the furnace voltage is switched ON and OFF intermittently. When the voltage supply is switched off, heat production within the surface is stalled and hence its temperature is reduced. When the supply is restored, heat production starts and the furnace temperature begins to increase. Hence, by this simple method, the furnace temperature can be limited between two limits.

(2) By Changing the Number of

Heating Elements. In this case, the number of heating elements is changed without cutting off the supply to the entire furnace. Smaller the number of heating elements, lesser the heat produced. In the case of a 3-phase circuit, equal number of heating elements is switched off from each phase in order to maintain a balanced load condition.

(3) Variation in Circuit Configuration. In the case of 3-phase secondary load, the heating elements give less heat when connected in a star than when connected in delta because in the two cases, voltages across the elements is different (Fig.1.4). In single-phase circuits, series and parallel grouping of the heating elements causes change in power dissipation resulting in change of furnace temperature.

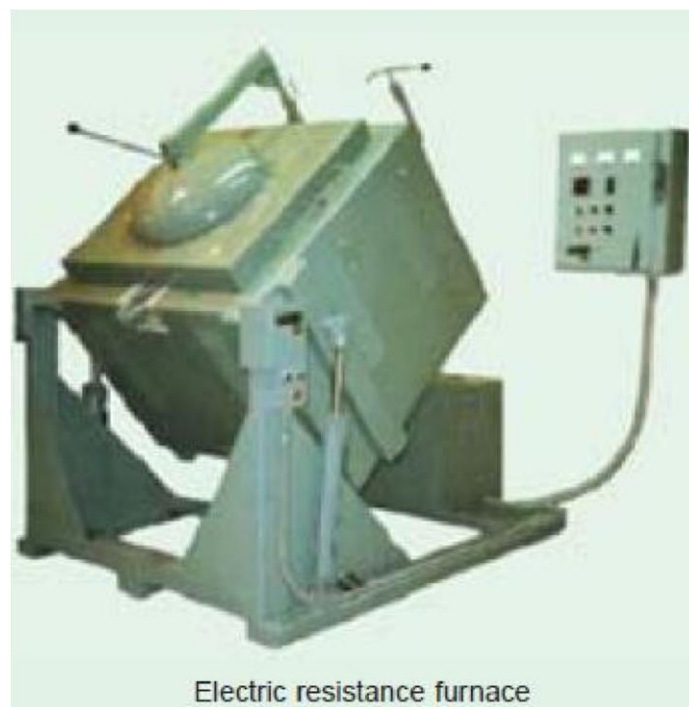

As shown in Fig. 47.5 heat produced is more when all these elements are connected in parallel than when they are connected in series or series-parallel.

(4) Change of Applied Voltage. (a) Obviously, lesser the magnitude of the voltage applied to the load, lesser the power dissipated and hence, lesser the temperature produced. In the case of a furnace transformer having high voltage primary, the tapping control is kept in the primary winding because the magnitude of the primary current is less. Consider the multi-tap step-down transformer shown in Fig. 1.6.

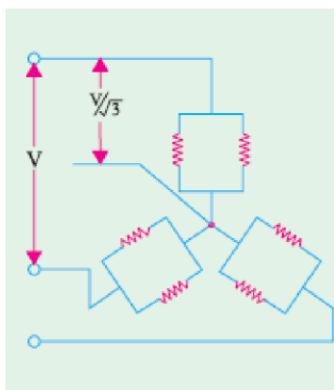

Fig1.5

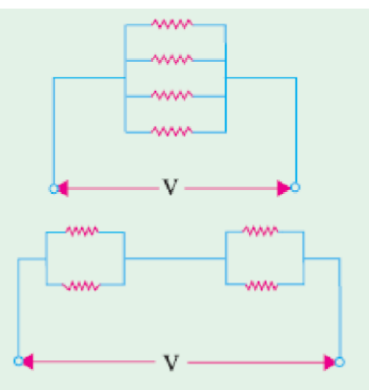
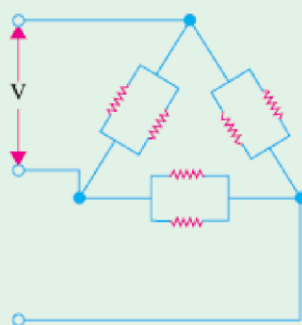

Fig1.6

(b) Bucking-Boosting the Secondary Voltage. In this method, the transformer secondary is wound in two sections having unequal number of turns. If the two sections are connected in series aiding, the secondary voltage is boosted *i.e.*, increased to $(E_2 + E_3)$ as shown in Fig.1.7 (a).

When the two sections are connected in series-opposing [Fig. 1.7 (b)] the secondary voltage is reduced *i.e.*, there is bucking effect. Consequently, furnace voltage becomes $(E_2 - E_3)$ and, hence, furnace temperature is reduced.

(c) **Autotransformer Control.** Fig. 47.8 shows the use of tapped autotransformer used for decreasing the furnace voltage and, hence, temperature of small electric furnaces. The required voltage can be selected with the help of a voltage selector.

(d) **Series Reactor Voltage.** In this case, a heavy-duty core-wounded coil is placed in series with the furnace as and when desired. Due to drop in voltage across the impedance of the coil, the voltage available across the furnace is reduced. With the help of D.P.D.T. switch, high/low, two mode temperature control can be obtained as shown in the Fig. 47.9. Since the addition of series coil reduces the power factor, a power capacitor is simultaneously introduced in the circuit for keeping the p.f. nearly unity. As seen, the inductor is connected in series, whereas the capacitor is in parallel with the furnace.

Design of Heating Element

Normally, wires of circular cross-section or rectangular conducting ribbons are used as heating elements. Under steady-state conditions, a heating element dissipates as much heat from its surface as it receives the power from the electric supply. If P is the power input and H is the heat dissipated by radiation, then $P = H$ under steady-state conditions.

As per Stefan's law of radiation, heat radiated by a hot body is given by

$$H = 5.72 eK \left[\left(\frac{T_1}{100} \right)^4 - \left(\frac{T_2}{100} \right)^4 \right] \text{W/m}^2$$

where T_1 is the temperature of hot body in $^{\circ}K$ and T_2 that of the cold body (or cold surroundings) in $^{\circ}K$

$$\text{Now, } P = \frac{V^2}{R}, \text{ and } R = \rho \frac{l}{A} = \rho \frac{l}{\pi d^2 / 4} = \frac{4\rho l}{\pi d^2}$$

$$\therefore P = \frac{V^2}{4\rho l / \pi d^2} = \frac{\pi d^2 V^2}{4\rho l} \text{ or } \frac{l}{d^2} = \frac{\pi V^2}{4\rho}$$

Total surface area of the wire of the element = $(\pi d) \times l$i

If H is the heat dissipated by radiation per second per unit surface area of the wire, then heat radiated per second = $(\pi d) \times l \times H$ii

Equating (i) and (ii), we have

$$P = (\pi d) \times l \times H \text{ or } \frac{\pi d^2 V^2}{4\rho l} = (\pi d) \times H \text{ or } \frac{d}{l^2} = \frac{4\rho H}{V^2} \dots\dots\dots iii$$

We can find the values of l and d from Eq. (i) and (iii) given above.

Ribbon Type Element

If w is the width of the ribbon and t its thickness, then

$$P = \frac{V^2}{R} = \frac{V^2}{\rho l / A} = \frac{V^2}{\rho l / Twt} = \frac{wtV^2}{\rho l} \text{ or } \frac{t}{wt} = \frac{V^2}{\rho P} \dots\dots\dots iv$$

Heat lost from ribbon surface = $2wlH$ (neglecting the side area $2tl$)

$$\therefore \frac{wtV^2}{\rho l} = 2wlH \text{ or } \frac{t}{l^2} = \frac{2\rho H}{V^2} \dots\dots\dots v$$

Values of l and w for a given ribbon of thickness t can be found from Eqn. (iv) and (v) given above.

Arc Furnaces

If a sufficiently high voltage is applied across an air-gap, the air becomes ionized and starts conducting in the form of a continuous spark or arc thereby producing intense heat. When electrodes are made of carbon/graphite, the temperature obtained is in the range of 3000°C-

3500C. The high voltage required for striking the arc can be obtained by using a step-up transformer fed from a variable a.c. supply as shown in Fig. 1.10 (a).

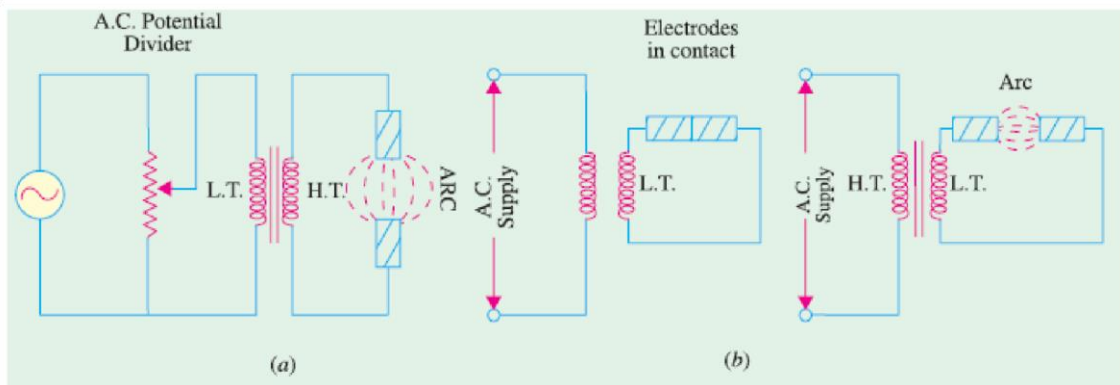

Fig1.10

An arc can also be obtained by using low voltage across two electrodes initially in contact with each other as shown in Fig. 1.10 (b). The low voltage required for this purpose can be obtained by using a step-down transformer. Initially, the low voltage is applied, when the two electrodes are in contact with each other. Next, when the two electrodes are gradually separated from each other, an arc is established between the two.

Arc furnaces can be of the following two types :

1. Direct Arc Furnace

In this case, arc is formed between the two electrodes and the charge in such a way that electric current passes through the body of the charge as shown in Fig. 47.11 (a). Such furnaces produce very high temperatures.

2. Indirect Arc Furnace

In this case, arc is formed between the two electrodes and the heat thus produced is passed on to the charge by radiation as shown in Fig. 1.11 (b).

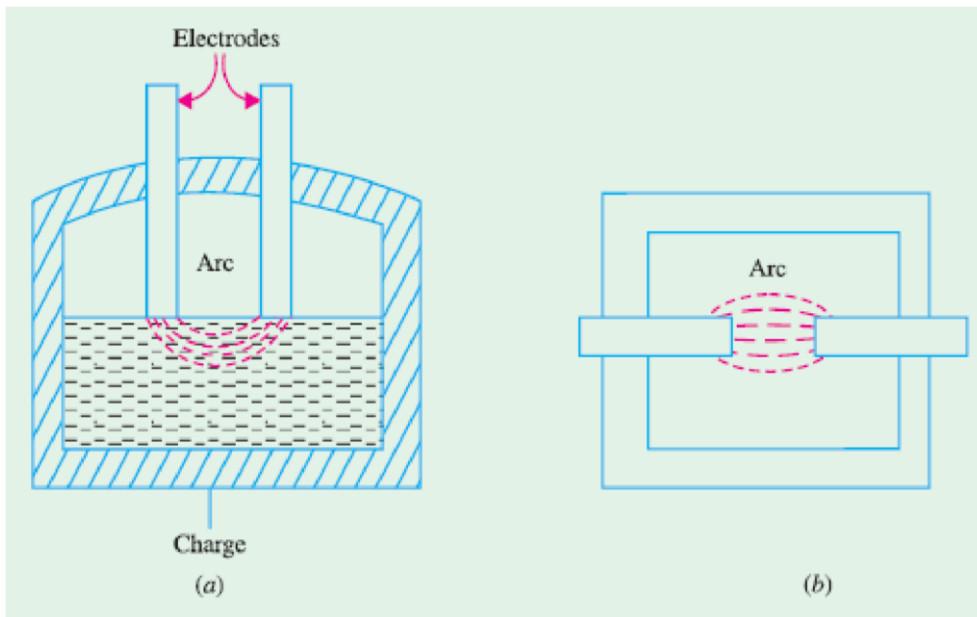

Fig1.11

Direct Arc Furnace

It could be either of conducting-bottom type [Fig. 1.12 (a)] or non-conducting bottom type [Fig. 1.12 (b)]. As seen from Fig. 47.12 (a), bottom of the furnace forms part of the electric circuit so that current passes through the body of the charge which offers very low resistance. Hence, it is possible

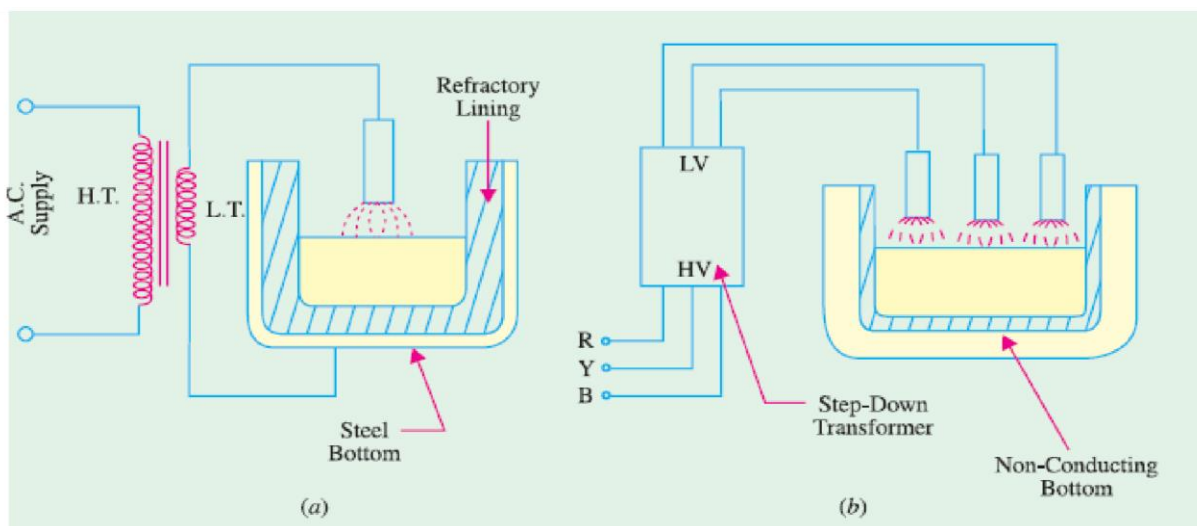

Fig 1.12

to obtain high temperatures in such furnaces. Moreover, it produces uniform heating of charge without stirring it mechanically. In Fig. 47.12 (b), no current passes through the body of the furnace.

Most common application of these furnaces is in the production of steel because of the ease with which the composition of the final product can be controlled during refining.

Most of the furnaces in general use are of non-conducting bottom type due to insulation problem faced in case of conducting bottom.

Indirect Arc Furnace

Fig. 1.13 shows a single-phase indirect arc furnace which is cylindrical in shape. The arc is struck by shortcircuiting the electrodes manually or automatically for a moment and then, withdrawing them apart. The heat from the arc and the hot refractory lining is transferred to the top layer of the charge by radiation. The heat from the hot top layer of the charge is further transferred to other parts of the charge by conduction. Since no current passes through the body of the charge, there is no inherent stirring action due to electro-magnetic forces set up by the current. Hence, such furnaces have to be rocked continuously in order to distribute heat uniformly by exposing different layers of the charge to the heat of the arc. An electric motor is used to operate suitable grinders and rollers to impart rocking motion to the furnace. Rocking action provides not only thorough mixing of the charge, it also increases the furnace efficiency in addition to increasing the life of the refractory lining material. Since in this furnace, charge is heated by radiation only, its temperature is lower than that obtainable in a direct arc furnace. Such furnaces are mainly used for melting nonferrous metals although they can be used in iron foundries where small quantities of iron are required frequently.

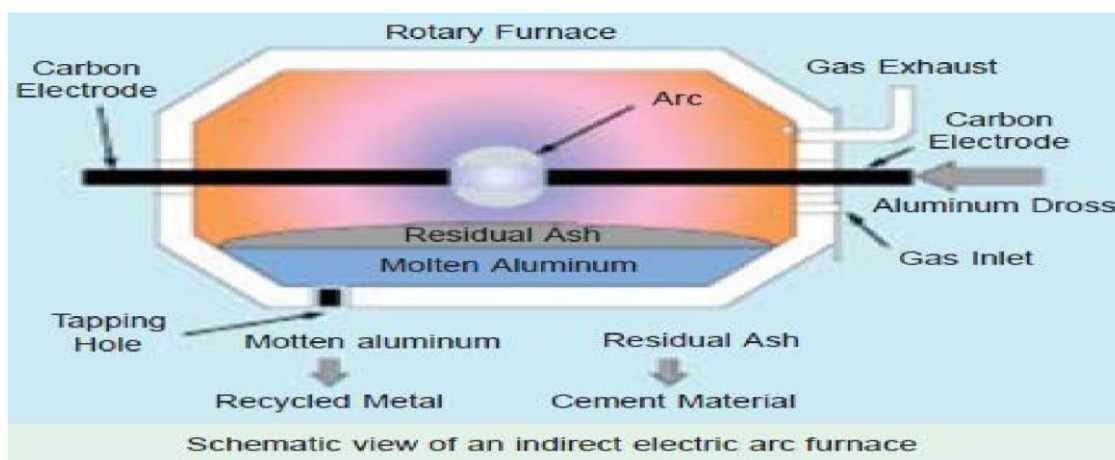

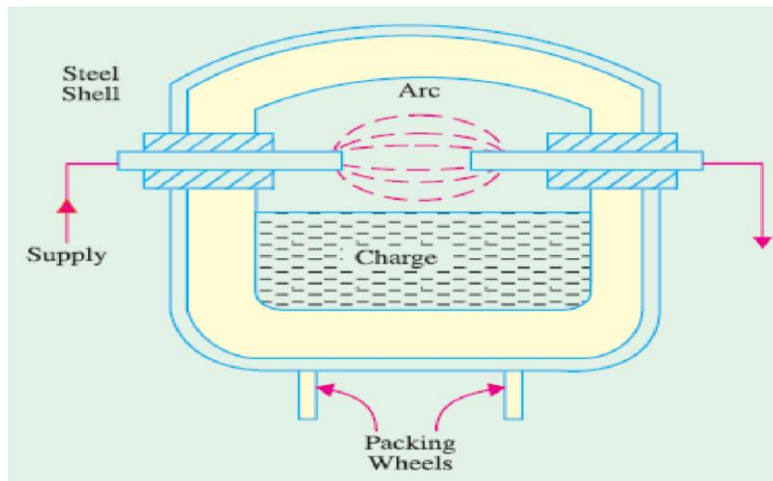

Fig1.13

Induction Heating

This heating process makes use of the currents induced by the electro-magnetic action in the charge to be heated. In fact, induction heating is based on the principle of transformer working. The primary winding which is supplied from an a.c. source is magnetically coupled to the charge which acts as a short circuited secondary of single turn. When an a.c. voltage is applied to the primary, it induces voltage in the secondary *i.e.* charge. The secondary current heats up the charge in the same way as any electric current does while passing through a resistance. If V is the voltage induced in the charge and R is the charge resistance, then heat produced = V^2/R . The value of current induced in the charge depends on (i) magnitude of the primary current (ii) turn ratio of the transformer

(iii) co-efficient of magnetic coupling. Low-frequency induction furnaces are used for melting and refining of different metals. However, for other processes like case hardening and soldering etc., high-frequency eddy-current heating is employed. Low frequency induction furnaces employed for the melting of metals are of the following two types :

- (a) **Core-type Furnaces** — which operate just like a two winding transformer. These can be further sub-divided into (i) Direct core-type furnaces (ii) Vertical core-type furnaces and (iii) Indirect core-type furnaces.
- (b) **Coreless-type Furnaces** — in which an inductively-heated element is made to transfer heat to the charge by radiation.

Core Type Induction Furnace

It is shown in Fig. 1.14 and is essentially a transformer in which the charge to be heated forms a single-turn short-circuited secondary and is magnetically coupled to the primary by an iron core. The furnace consists of a circular hearth which contains the charge to be melted in the form of an annular ring. When there is no molten metal in the ring, the secondary becomes open-circuited there-by cutting off the secondary current. Hence, to start the furnace, molten metal has to be poured in the annular hearth. Since, magnetic coupling between the primary and secondary is very poor, it results in high leakage and low power factor. In order to nullify the effect of increased leakage reactance, low primary frequency of the order of 10 Hz is used. If the transformer secondary current density exceeds 500 A/cm² then, due to the interaction of secondary current with the alternating magnetic field, the molten metal is squeezed to the extent that secondary circuit is interrupted. This effect is known as —pinch effectl.

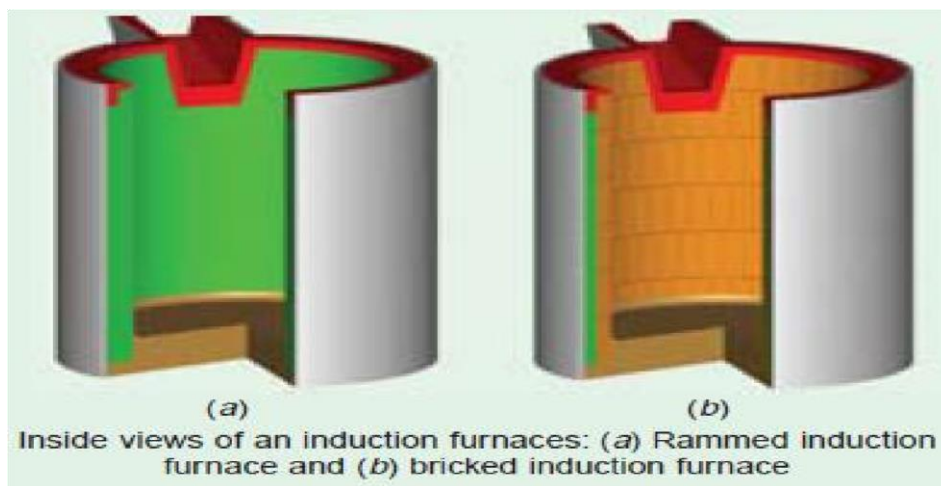

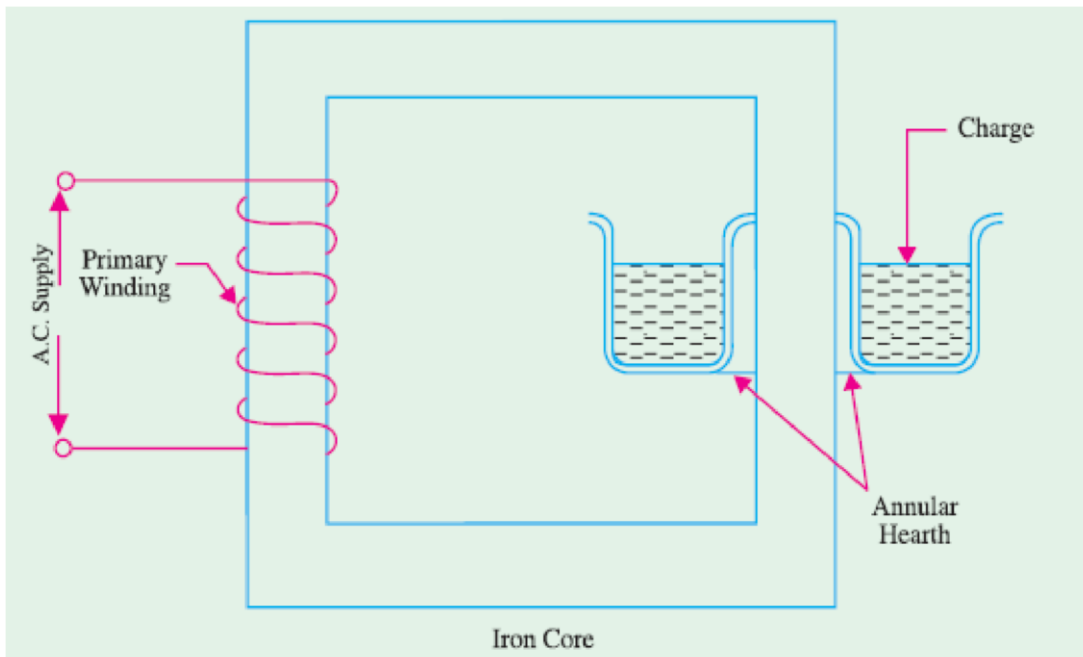
**Fig1.14**

This furnace suffers from the following drawbacks:

1. It has to be run on low-frequency supply which entails extra expenditure on motor-generator set or frequency convertor.
2. It suffers from pinching effect.
3. The crucible for charge is of odd shape and is very inconvenient for tapping the molten charge.
4. It does not function if there is no molten metal in the hearth *i.e.* when the secondary is open. Every time molten metal has to be poured to start the furnace.
5. It is not suitable for intermittent service. However, in this furnace, melting is rapid and clean and temperature can be controlled easily.

Moreover, inherent stirring action of the charge by electro-magnetic forces ensures greater uniformity of the end product.

Vertical Core-Type Induction Furnace

It is also known as Ajax-Wyatt furnace and represents an improvement over the core-type furnace discussed above. As shown in Fig., it has vertical channel (instead of a horizontal one) for the charge, so that the crucible used is also vertical which is convenient from metallurgical

point of view. In this furnace, magnetic coupling is comparatively better and power factor is high. Hence, it can be operated from normal frequency supply. The circulation of the molten metal is kept up round the Vee portion by convection currents as shown in Fig. 1.15. As Vee channel is narrow, even a small quantity of charge is sufficient to keep the secondary circuit closed. However, Vee channel must be kept full of charge in order to maintain continuity of secondary circuit.

This fact makes this furnace suitable for continuous operation. The tendency of the secondary circuit to rupture due to pinch-effect is counteracted by the weight of the charge in the crucible. The choice of material for inner lining of the furnace depends on the type of charge used. Clay lining is used for yellow brass. For red brass and bronze, an alloy of magnetia and alumina or corundum is used. The top of the furnace is covered with an insulated cover which can be removed for charging. The furnace can be tilted by the suitable hydraulic arrangement for taking out the molten metal.

This furnace is widely used for melting and refining of brass and other non-ferrous metals. As said earlier, it is suitable for continuous operation. It has a p.f. of 0.8-0.85. With normal supply frequency, its efficiency is about 75% and its standard size varies from 60-300 kW, all single-phase.

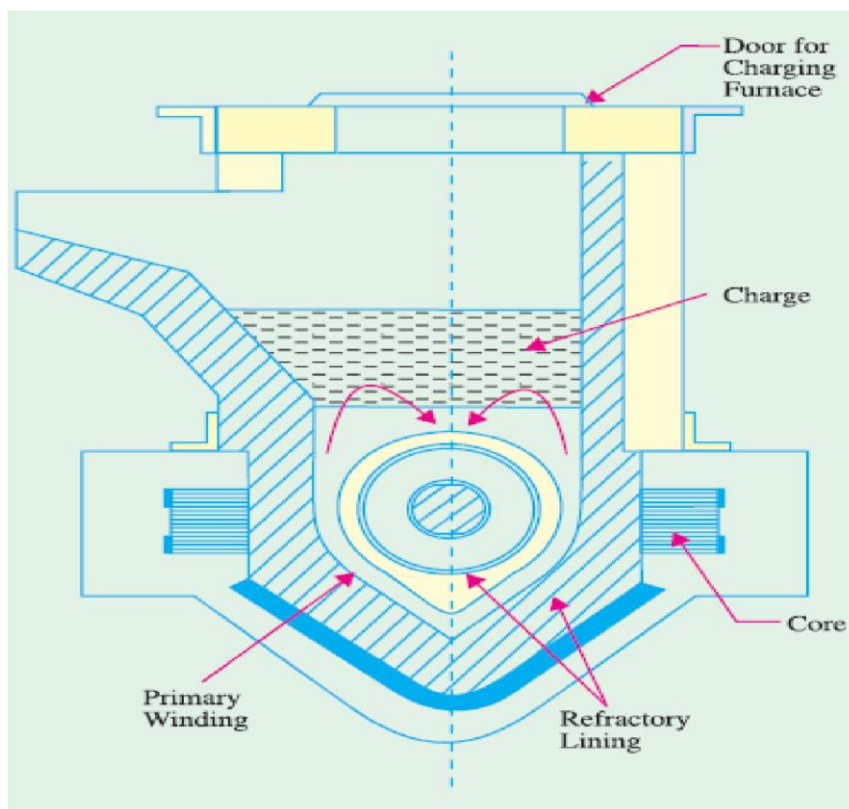

Fig1.15**Indirect Core-Type Induction Furnace**

In this furnace, a suitable element is heated by induction which, in turn, transfers the heat to the charge by radiation. So far as the charge is concerned, the conditions are similar to those in a resistance oven.

As shown in Fig. 1.16, the secondary consists of a metal container which forms the walls of the furnace proper. The primary winding is magnetically coupled to this secondary by an iron core. When primary winding is connected to a.c. supply, secondary current is induced in the metal container by transformer action which heats up the container. The metal container transfers this heat to the charge. A special advantage of this furnace is that its temperature can be automatically controlled without the use of an external equipment. The part AB of the magnetic circuit situated inside the oven chamber consists of a special alloy which loses its magnetic properties at a particular temperature but regains them when cooled back to the same temperature. As soon as the chamber attains the critical temperature, reluctance of the magnetic circuit increases manifold thereby cutting off the heat supply. The bar AB is detachable and can be replaced by other bars having different critical temperatures.

Coreless Induction Furnace

As shown in Fig. 1.17, the three main parts of the furnace are (i) primary coil (ii) a ceramic crucible containing charge which forms the secondary and (iii) the frame which includes supports and tilting mechanism. The distinctive feature of this furnace is that it contains no heavy iron core with the result that there is no continuous path for the magnetic flux. The crucible and the coil are relatively light in construction and can be conveniently tilted for pouring. The charge is put into the crucible and primary winding is connected to a high-frequency a.c. supply. The flux produced by the primary sets up eddy-currents in the charge and heats it up to the melting point. The charge need not be in the molten state at the start as was required by core-type furnaces. The eddy-currents also set up electromotive forces which produce stirring action which is essential for obtaining uniform quality of metal. Since flux

density is low (due to the absence of the magnetic core) high frequency supply has to be used because eddy-current loss W_e . However, this high frequency increases the resistance of the primary winding due to skin effect, thereby increasing primary Cu losses. Hence, the primary winding is not made of Cu wire but consists of hollow Cu tubes which are cooled by water circulating through them. Since magnetic coupling between the primary and secondary windings is low, the furnace p.f. lies between 0.1 and 0.3. Hence, static capacitors are invariably used in parallel with the furnace to improve its p.f.

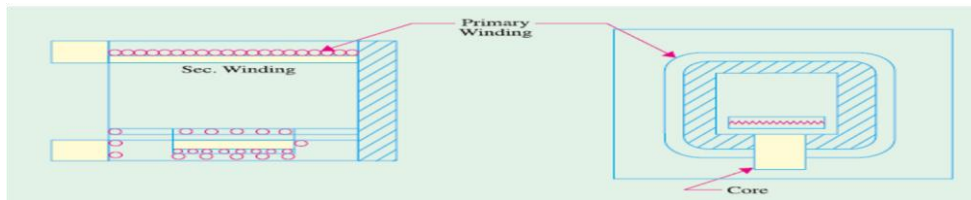

Fig1.16

Such furnaces are commonly used for steel production and for melting of non-ferrous metals like brass, bronze, copper and aluminium etc., along with various alloys of these elements. Special application of these furnaces include vacuum melting, melting in a controlled atmosphere and melting for precision casting where high frequency induction heating is used. It also finds wide use in electronic industry and in other industrial activities like soldering, brazing hardening and annealing and sterilizing surgical instruments etc. Some of the advantages of coreless induction furnaces are as follows :

- (1) They are fast in operation.
- (2) They produce most uniform quality of product.
- (3) They can be operated intermittently.
- (4) Their operation is free from smoke, dirt, dust and noises.
- (5) They can be used for all industrial applications requiring heating and melting.
- (6) They have low erection and operating costs.
- (7) Their charging and pouring is simple.

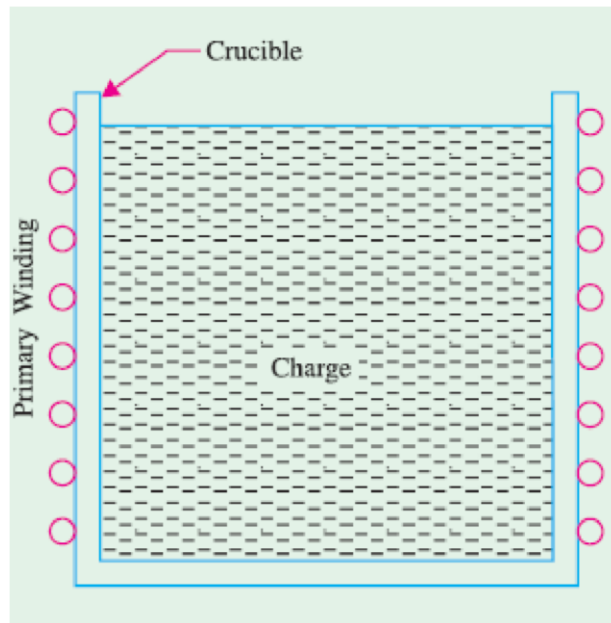

Fig1.17

High Frequency Eddy-current Heating

For heating an article by eddy-currents, it is placed inside a high frequency a.c. current-carrying coil (Fig. 1.18). The alternating magnetic field produced by the coil sets up eddy-currents in the article which, consequently, gets heated up. Such a coil is known as heater coil or work coil and the material to be heated is known as **charge or load**. Primarily, it is the eddy-current loss which is responsible for the production of heat although hysteresis loss also contributes to some extent in the case of non-magnetic materials.

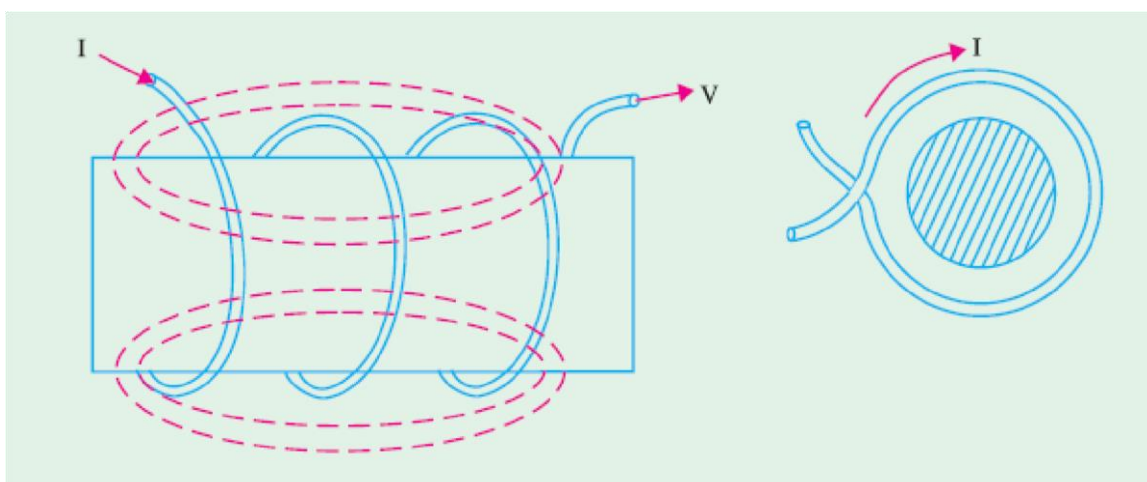

Fig1.18

The eddy-current loss $W_e \propto B^2 f^2$. Hence, this loss can be controlled by controlling flux density B and the supply frequency f . This loss is greatest on the surface of the material but decreases as we go deep inside. The depth of the material upto which the eddy-current loss penetrates is given by

$$d = \frac{1}{2\pi} \sqrt{\frac{\rho \times 10^9}{\mu_r \cdot f}}$$

where ρ = resistivity of the molten metal
 f = supply frequency
 μ_r = relative permeability of the charge

Advantages of Eddy-current Heating

- (1) There is negligible wastage of heat because the heat is produced in the body to be heated.
- (2) It can take place in vacuum or other special environs where other types of heating are not possible.
- (3) Heat can be made to penetrate any depth of the body by selecting proper supply frequently.

Applications of Eddy-current Heating

- (1) **Surface Hardening.** The bar whose surface is to be hardened by heat treatment is placed within the working coil which is connected to an a.c. supply of high frequency. The depth upto which the surface is to be hardened can be obtained by the proper selection of frequency of the coil current. After a few seconds, when surface has reached the proper temperature, a.c. supply is cut off and the bar is at once dipped in water.
- (2) **Annealing.** Normally, annealing process takes long time resulting in scaling of the metal which is undesirable. However, in eddy-current heating, time taken is much less so that no scale formation takes place.
- (3) **Soldering.** Eddy-current heating is economical for precise high-temperature soldering where silver, copper and their alloys are used as solders.

Dielectric Heating

It is also called high-frequency capacitive heating and is used for heating insulators like wood, plastics and ceramics etc. which cannot be heated easily and uniformly by other methods. The supply frequency required for dielectric heating is between 10-50 MHz and the applied voltage is upto 20 kV. The overall efficiency of dielectric heating is about 50%.

Dielectric Loss

When a practical capacitor is connected across an a.c. supply, it draws a current which leads the voltage by an angle ϕ which is a little less than 90° or falls short of 90° by an angle δ . It means that there is a certain component of the current which is in phase with the voltage and hence produces some loss called dielectric loss. At the normal supply frequency of 50 Hz, this loss is negligibly small but at higher frequencies of 50 MHz or so, this loss becomes so large that it is sufficient to heat the dielectric in which it takes place. The insulating material to be heated is placed between two conducting plates in order to form a parallel-plate capacitor as shown in Fig. 1.19 (a).

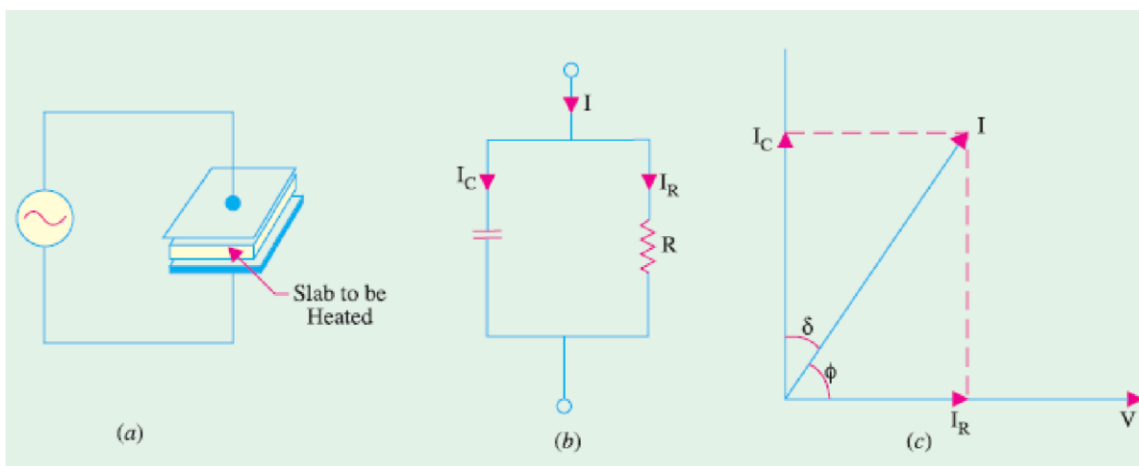

Fig1.19

Fig. 1.19 (b) shows the equivalent circuit of the capacitor and Fig. 1.19 (c) gives its vector diagram.

where d is the thickness and A is ϕ the surface area of the dielectric slab. This power is converted into heat. Since ϕ for a given insulator material, C and δ are constant, the dielectric loss ϕ is directly proportional to $V^2 f$. That is why high-frequency voltage is used in dielectric heating. Generally, a.c. voltage of about 20 kV at a frequency of 10-30 MHz is used.

Advantages of Dielectric Heating

1. Since heat is generated within the dielectric medium itself, it results in uniform heating.
2. Heating becomes faster with increasing frequency.
3. It is the only method for heating bad conductors of heat.
4. Heating is fastest in this method of heating.
5. Since no naked flame appears in the process, inflammable articles like plastics and wooden products etc., can be heated safely.
6. Heating can be stopped immediately as and when desired

Applications of Dielectric Heating

Since cost of dielectric heating is very high, it is employed where other methods are not possible or are too slow. Some of the applications of dielectric heating are as under:

1. For gluing of multilayer plywood boards.
2. For baking of sand cores which are used in the moulding process.
3. For preheating of plastic compounds before sending them to the moulding section.
4. For drying of tobacco after glycerine has been mixed with it for making cigarettes.
5. For baking of biscuits and cakes etc. in bakeries with the help of automatic machines.
6. For electronic sewing of plastic garments like raincoats etc. with the help of cold rollers fed with high-frequency supply.
7. For dehydration of food which is then sealed in air-tight containers.
8. For removal of moistures from oil emulsions.
9. In diathermy for relieving pain in different parts of the human body.
10. For quick drying of glue used for book binding purposes.

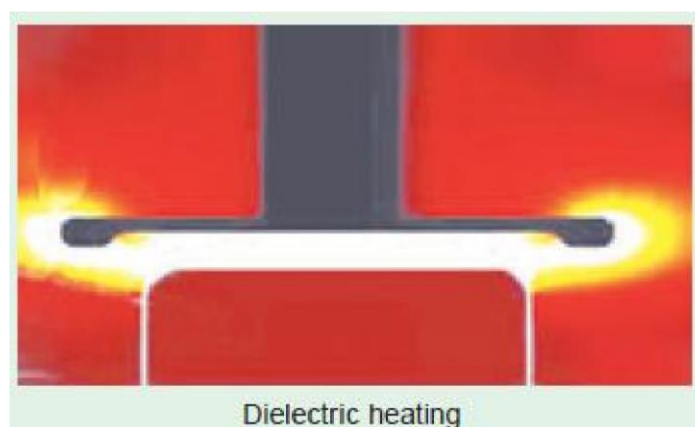

Choice of Frequency

The selection of frequency for heating is important because it has a great bearing on the work to be heated and the method of its heating whether by induction heating or dielectric heating. Furnaces running on power frequency of 50 Hz can be of 1 MW capacity whereas those running on medium frequencies (500 Hz to 1000 Hz) have a capacity of 50 kW and those running on high frequency (1 MHz to 2 MHz) have capacities ranging from 200 kW to 500 kW.

1. Induction Heating. While choosing frequency for induction heating, the following factors are considered :

- (a) Thickness of the surface to be heated. Higher the frequency, thinner the surface that will get heated.
- (b) The time of continuous heating. Longer the duration of heating, deeper the penetration of heat in the work due to conduction.
- (c) The temperature to be obtained. Higher the temperature, higher the capacity of the generator required.

Dielectric Heating. The power consumed during dielectric heating,

$P = 2 \pi f CV^2 \cos \phi$. As seen, $P \propto f \times C \times V^2 \times \cos \phi$. Hence, rate of heat production can be increased by increasing voltage or voltage across any specimen is limited by its thickness or because of the consideration of potential gradient, breakdown voltage and safety etc., Voltages ranging from 600 V to 3000 V are used for dielectric heating, although voltages of 20 kV or so are also used sometimes. Rate of heat production can also be increased by applying high potential but it is also limited because of the following considerations: (a) Possibility of formation of standing waves between the surface of two electrodes having wavelength nearly equal to or more than one quarter of the wavelength of the particular frequency used.

(b) Necessity of employing special matching circuit at higher frequencies due to the fact that

maximum power transfer takes place when the oscillator impedance equals the load impedance.

(c) At higher frequencies it is difficult for tuning inductance to resonate with the charge capacitance.

(d) At higher frequencies, it is almost impossible to get uniform voltage distribution.

- (e) Since higher frequencies disturb near-by radio station services, special arrangement has to be made to stop radiations from the high-frequency generator used for the purpose.

When tungsten filament lamps are operated at about 2300°C (instead of 3000°C), they produce plenty of heat radiations called *infrared radiations*. With the help of suitable reflectors, these infrared radiations are focused on the surface to be heated. The lamps so employed have ratings varying from 250 W to 1000 W operating at 115 V. Lower voltage results in robust filaments. With this arrangement, the charge temperature obtained is between 200°C and 300°C. The heat emission intensity obtained is about 7000 W/m² as compared to 1500 W/m² obtained with ordinary resistance furnaces. In this type of heating, heat absorption remains practically constant whatever the charge temperature whereas it falls rapidly as the temperature of charge rises in the ordinary resistance furnace. Infrared heating is used for paint drying and for drying foundry moulds, for low temperature heating of plastics and for various dehydration and other processes.

ELECTRIC WELDING

Definition of Welding

It is the process of joining two pieces of metal or non-metal at faces rendered plastic or liquid by the application of heat or pressure or both. Filler material may be used to effect the union.

Welding Processes

All welding processes fall into two distinct categories:

1. Fusion Welding—It involves melting of the parent metal. Examples are:

- (i) Carbon arc welding, metal arc welding, electron beam welding, electroslag welding and electrogas welding which utilize electric energy and
- (ii) Gas welding and thermit welding which utilize chemical energy for the melting purpose.

2. Non-fusion Welding—It does not involve melting of the parent metal. Examples are:

- (i) Forge welding and gas non-fusion welding which use chemical energy.

- (ii) Explosive welding, friction welding and ultrasonic welding etc., which use mechanical energy.
- (iii) Resistance welding which uses electrical energy.

Proper selection of the welding process depends on the (a) kind of metals to be joined (b) cost involved (c) nature of products to be fabricated and (d) production techniques adopted. The principal welding processes have been tabulated in Fig. 1.20

Use of Electricity in Welding

Electricity is used in welding for generating heat at the point of welding in order to melt the material which will subsequently fuse and form the actual weld joint. There are many ways of producing this localised heat but the two most common methods are as follows:

1. **Resistance welding**—here current is passed through the inherent resistance of the joint to be welded thereby generating the heat as per the equation $I^2 R t / J$ kilocalories.
2. **Arc welding**—here electricity is conducted in the form of an arc which is established between the two metallic surfaces

Formation and Characteristics of Electric Arc

An electric arc is formed whenever electric current is passed between two metallic electrodes which are separated by a short distance from each other. The arc is started by momentarily touching the positive electrode (anode) to the negative metal (or plate) and then withdrawing it to about 3 to 6 mm from the plate. When electrode first touches the plate, a large short-circuit current flows and as it is later withdrawn from the plate, current continues to flow in the form of a spark across the air gap so formed. Due to this spark (or discharge), the air in the gap becomes ionized *i.e.* is split into negative electrons and positive ions. Consequently, air becomes conducting and current is able to flow across the gap in the form of an arc.

As shown in Fig. 1.22, the arc consists of *lighter* electrons which flow from cathode to anode and *heavier* positive ions which flow from anode to cathode. Intense heat is generated when high velocity electrons strike the anode. Heat generated at the cathode is much less because of the low velocity of the impinging ions. It is found that nearly **two-third** of the heat is developed

at the anode which burns into the form of a crater where temperature rises to a value of 3500-4000°C. The remaining one-third of the heat is developed near the cathode. The above statement is true in all d.c. systems of welding where positive side of the circuit is the hottest side. As a result, an electrode connected to the positive end of the d.c. supply circuit will burn 50% faster than if connected to the negative end. This fact can be used for obtaining desired penetration of the base metal during welding.

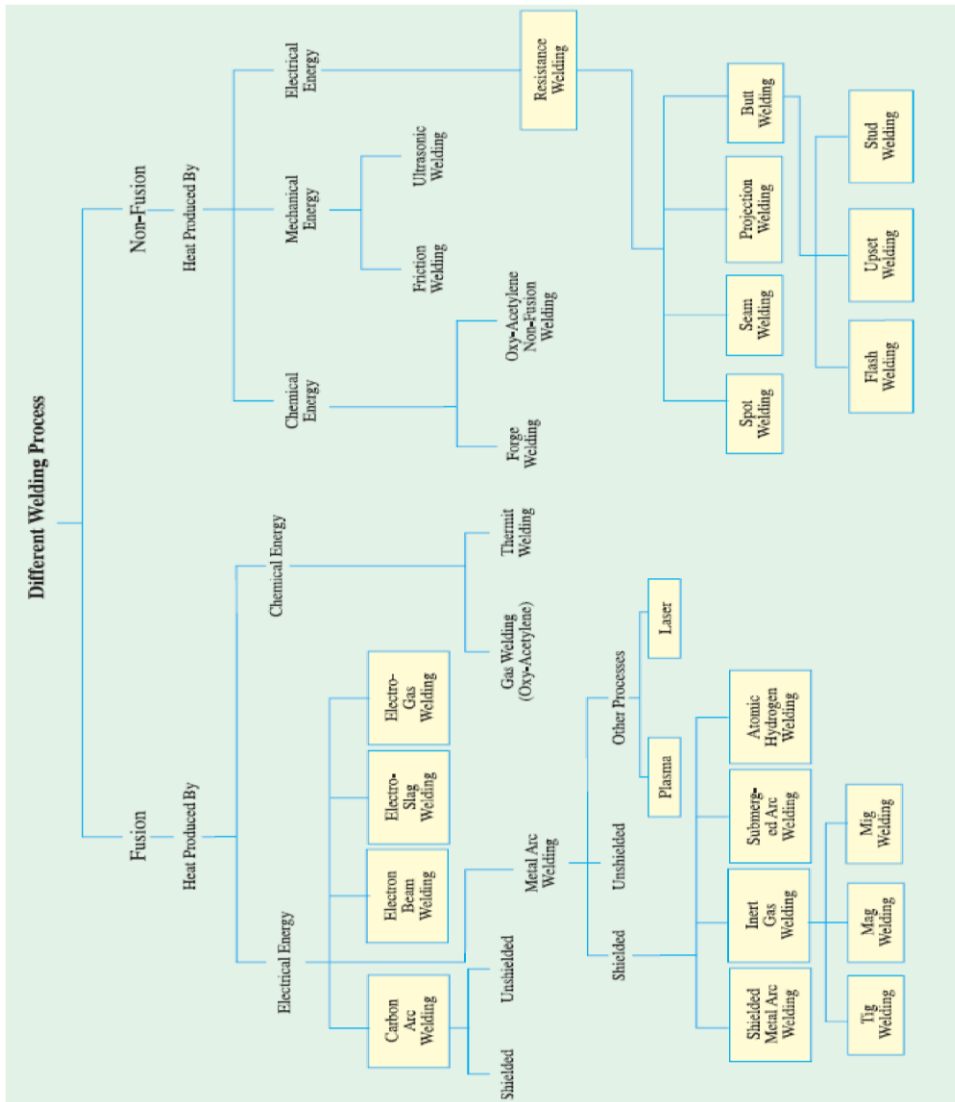

Fig 1.20

If positive supply end is connected to the base metal (which is normally grounded), penetration will be greater due to more heat and, at the same time, the electrode will burn away slowly [Fig. 1.23(a)] since it is connected to the negative end of the supply. If supply connections are reversed, the penetration of heat zone in the base metal will be comparatively shallow and, at the same time, electrode will burn fast [Fig.1.23 (b)]. AC supply produces a penetration depth that is

early halfway between that achieved by the d.c. positive ground and negative ground as shown in Fig.1.23(c). It may be noted that with a.c. supply, heat is developed equally at the anode and cathode due to rapid reversal of their polarity. The arc utilized for arc welding is a low-voltage high-current discharge. The voltage required for striking the arc is higher than needed for maintaining it. Moreover, amperage increases as voltage decreases after the arc has been established. Fig 1.24 shows V/I characteristics of an electric arc for increasing air-gap lengths. The voltage required to strike a d.c. arc is about 50-55 V and that for a.c. arc is 80-90 V. The voltage drop across the arc is nearly 15-20 V. It is difficult to maintain the arc with a voltage less than 14 V or more than 40 V.

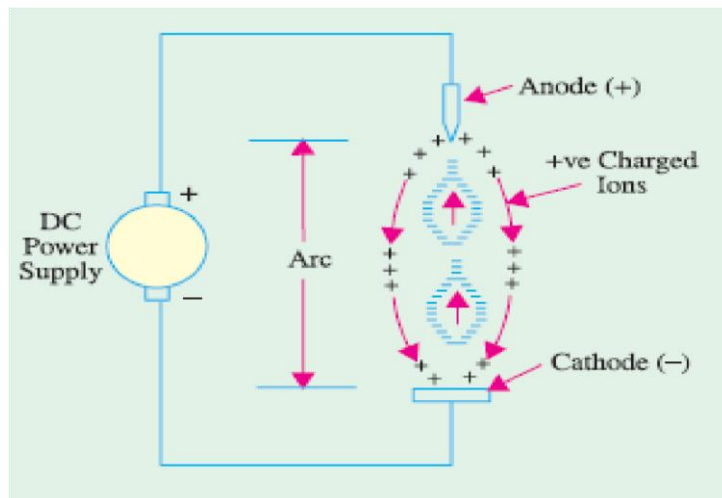

Fig1.22

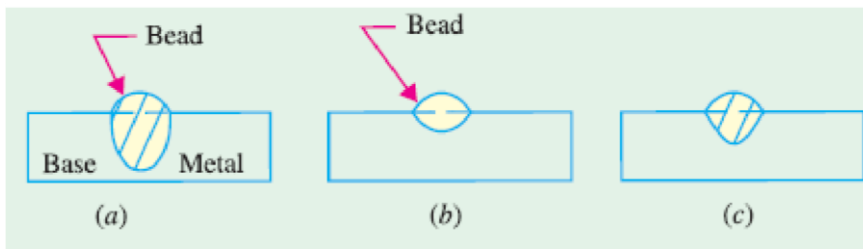

Fig 1.23

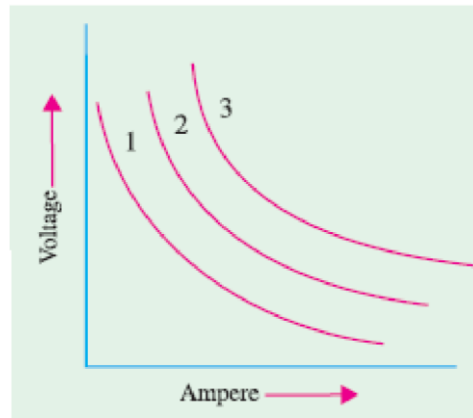
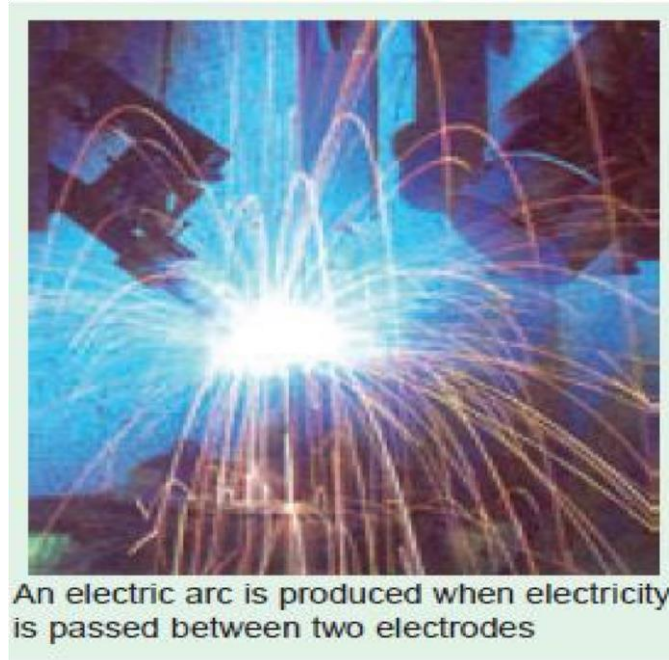

Fig1.24

Effect of Arc Length

In metal arc welding, a fairly short arc length is necessary for getting good welds. Short arc length permits the heat to be concentrated on the workpiece, is more stable because effect of magnetic blow is reduced and the vapours from the arc surround the electrode metal and the molten pool thereby preventing air from destroying the weld metal. When arc length is long

1. large amount of heat is lost into the surrounding area thus preventing good penetration and fusion;
2. arc flame is very unstable since effect of magnetic blow is increased. Hence, arc flame will have a tendency to blow out;
3. air is able to reach the molten globule of metal as it passes from the electrode to the weld and weld pool. It leads to the contamination of the weld due to absorption of oxygen and nitrogen;
4. weld deposits have low strength, poor ductility, high porosity, poor fusion and excessive spatter. The length of arc required for welding will depend on the kind of electrode used, its coating, its diameter, position of welding and the amount of current used. Usually, shorter arc length are necessary for vertical, horizontal and overhead welding than for flat welding.



Arc Blow

An arc column can be considered as a flexible current-carrying conductor which can be easily deflected by the magnetic field set up in its neighbourhood by the

positive and negative leads from the d.c. welding set. The two leads carry currents in the opposite directions and hence, set up a repulsive magnetic force which pulls the arc away from the weld point particularly when welding corners where field concentration is maximum. The deflection of the arc is called **arc blow**. This condition is encountered only with d.c. welding sets and is especially noticeable when welding with bare electrodes. It is experienced most when using currents above 200 A or below 40 A. Due to arc blow, heat penetration in the required area is low which leads to incomplete fusion and bead porosity apart from excessive weld spatter.

Arc blow can be avoided by using a.c. rather than d.c. welding machines because reversing currents in the welding leads produce magnetic fields which cancel each other out thereby eliminating the arc blow. However, with d.c. welding machines, arc blow effects can be minimized by

(i) welding away from the earth ground connection, (ii) changing the position of the earth connection on the work, (iii) wrapping the welding electrode cable a few turns around the work, (iv) reducing the welding current or electrode size, (v) reducing the rate of travel of the electrode and (vi) shortening the arc column length etc.

Polarity in DC Welding

Arc welding with the electrode connected to the positive end of the d.c. supply is called reverse polarity.* Obviously, the workpiece is connected to the negative end.

A better name for d.c. reverse polarity (DCRP) is *electrode-positive* as shown in Fig. 1.25(a).

As stated earlier in Art. 48.4, two-third of the arc heat is developed at the anode. Hence, in DCRP welding, electrode is the hottest whereas work piece is comparatively cooler. Consequently, electrode burns much faster but weld bead is relatively shallow and wide. That is why thick and heavily coated electrodes are used in DCRP welding because they require more heat for melting. Arc welding with the electrode connected to the negative end of the d.c. supply is called **straight polarity**** Obviously, the workpiece is connected to the positive end as shown in Fig. 1.25 (b). A better name for d.c. straight polarity (DCSP) is *electrode-negative*

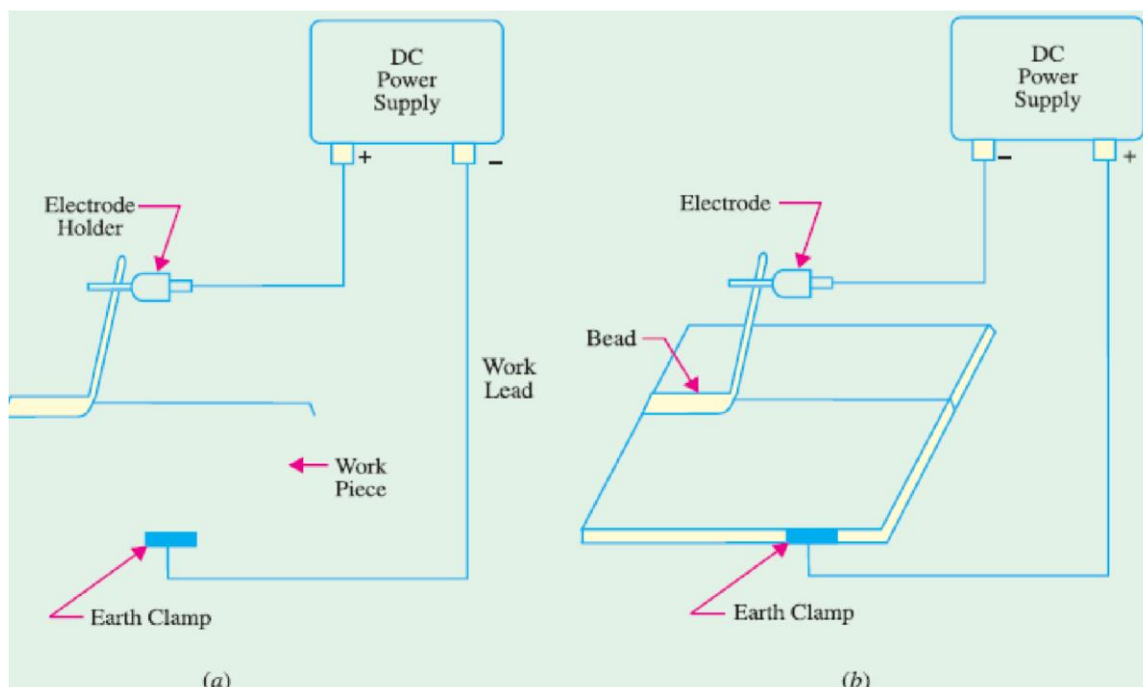

Fig 1.25

In DCSP welding, workpiece is the hottest, hence base metal penetration is narrow and deep. Moreover, bare and medium-coated electrodes can be used in this welding as they require less

amount of heat for melting. It is seen from the above discussion that polarity necessary for the welding operation is determined by the type of electrode used. It is also worth noting that in a.c. welding, there is no choice of polarity because the circuit becomes alternately positive, first on one side and then on the other. In fact, it is a combination of DCSP and DCRP.

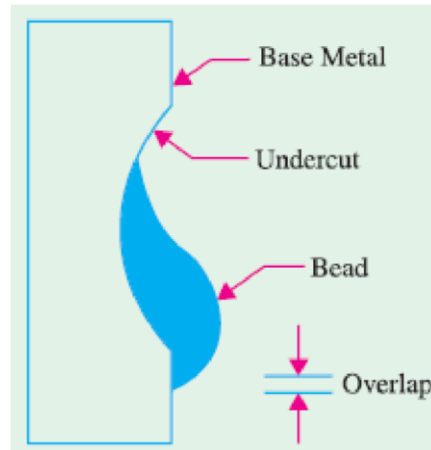

Fig1.26

Four Positions of Arc Welding

There are four basic positions in which manual arc welding is done.

- 1. Flat position.** It is shown in Fig. 1.27 (a). Of all the positions, flat position is the easiest, most economical and the most used for all shielded arc welding. It provides the strongest weld joints. Weld beads are exceedingly smooth and free of slag spots. This position is most adaptable for welding of both ferrous and non-ferrous metals particularly for cast iron.
- 2. Horizontal Position.** It is the second most popular position and is shown in Fig. 1.27(b). It also requires a short arc length because it helps in preventing the molten puddle of the metal from sagging. However, major errors that occur while welding in horizontal position are undercutting and over-lapping of the weld zone (Fig. 1.26).
- 3. Vertical Position.** It is shown in Fig. 1.27 (c). In this case, the welder can deposit the bead either in the uphill or downhill direction. Downhill welding is preferred for thin metals because it is faster than the uphill welding. Uphill welding is suited for thick metals because it produces stronger welds.

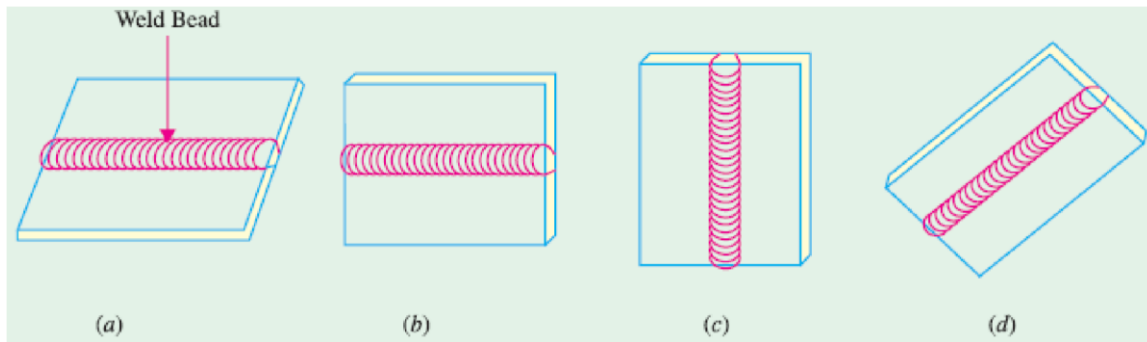

Fig 1.27

3. **Overhead Position.** It is shown in Fig.1.27 (d). Here, the welder has to be very cautious otherwise he may get burnt by drops of falling metal. This position is thought to be the most hazardous but not the most difficult one.

Electrodes for Metal Arc Welding

An electrode is a filler metal in the form of a wire or rod which is either bare or coated uniformly with flux. As per IS : 814-1970, the contact end of the electrode is left bare and clean to a length of 20-30 mm. for inserting it into electrode holder (Fig.

1.28)

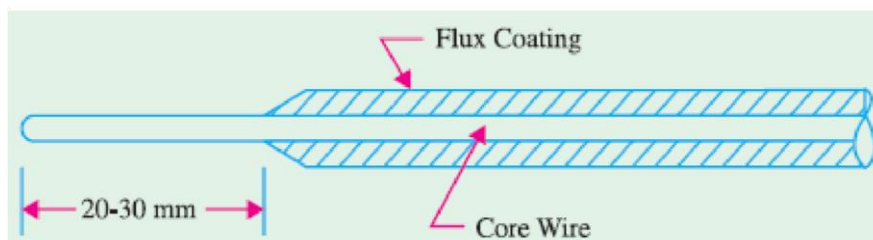

Fig1.28

Metal arc welding was originally done with bare electrodes which consisted of a piece of wire or rod of the same metal as the base metal. However, due to atmospheric contamination, they produced brittle and poor quality welds. Hence, bare wire is no longer used except for automatic welding in which case arrangement is made to protect the weld area from the atmosphere by

either powdered flux or an inert gas. Since 1929, coated electrodes are being extensively used for shielded arc welding.

They consist of a metal core wire surrounded by a thick flux coating applied by extrusion, winding or other processes. Depending on the thickness of the flux coating, coated electrodes may be classified into **(i)** lightly-dusted (or dipped) electrodes and **(ii)** semi-coated (or heavilycoated) electrodes. Materials commonly used for coating are **(i)** titanium oxide **(ii)** ferromanganese **(iii)** silica flour **(iv)** asbestos clay **(v)** calcium carbonate and **(vi)** cellulose with sodium silicate often used to hold ingredients together.

Electrode coating contributes a lot towards improving the quality of the weld. Part of the coating burns in the intense heat of the arc and provides a gaseous shield around the arc which prevents oxygen, nitrogen and other impurities in the atmosphere from combining with the molten metal to cause a poor quality brittle and weak weld. Another portion of the coating flux melts and mixes with the impurities in the molten pool causing them to float to the top of the weld where they cool in the form of slag (Fig. 1.29). This slag improves the bead quality by protecting it from the contaminating effects of the atmosphere and causing it to cool down more uniformly. It also helps in controlling the basic shape of the weld bead.

The type of electrode used depends on the type of metal to be welded, the welding position, the type of electric supply whether a.c. or d.c. and the polarity of the welding machine.

Advantages of Coated Electrodes

The principal advantages of using electrode coating are as under :

1. It stabilizes the arc because it contains ionizing agents such as compounds of sodium and potassium.
2. It fluxes away impurities present on the surface being welded.
3. It forms slag over the weld which **(i)** protects it from atmospheric contamination **(ii)** makes it cool uniformly thereby reducing the changes of brittleness and **(iii)** provides a smoother surface by reducing ‘ripples’ caused by the welding operation.
4. It adds certain materials to the weld metal to compensate for the loss of any volatile alloying elements or constituents lost by oxidization.
5. It speeds up the welding operation by increasing the rate of melting.
6. It prevents the sputtering of metal during welding.

7. it makes it possible for the electrode to be used on a.c. supply. In a.c. welding, arc tends to cool and interrupt at zero-current positions. But the shielding gases produced by the flux keep the arc space ionized thus enabling the coated electrodes to be used on a.c. supply. It is worth noting that efficiency of all coated (or covered) electrodes is impaired by dampness. Hence, they must always be stored in a dry space. If dampness is suspected, the electrodes should be dried in a warm cabinet for a few hours.

Types of Joints and Types of Applicable Welds

Bureau of Indian Standards (B.I.S.) has recommended the following types of joints and the welds applicable to each one of them (Fig. 1.30).

1. Tee joint — with six types of welds.
2. Corner joint — with two types of welds.
3. Edge joint — with one type of weld.
4. Lap joint — with four types of welds.
5. Butt joint — with nine types of welds.

Arc Welding Machines

Welding is never done directly from the supply mains. Instead, special welding machines are used which provided currents of various characteristics. Use of such machines is essential for the following reasons :

1. To convert a.c. supply into d.c. supply when d.c. welding is desired.
2. To reduce the high supply voltage to a safer and suitable voltage for welding purposes

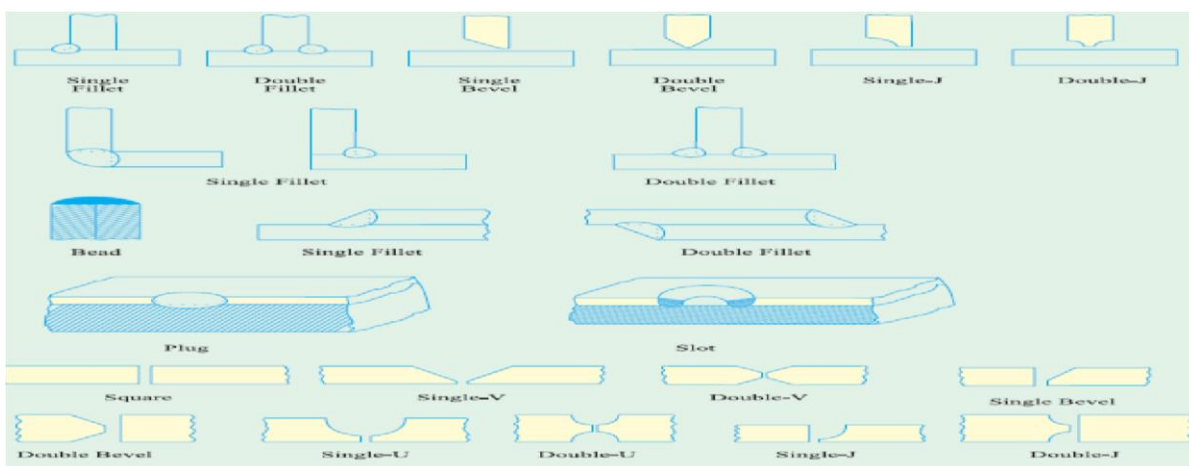

Fig 1.30

3. To provide high current necessary for arc welding without drawing a corresponding high current from the supply mains.
4. To provide suitable voltage/current relationships necessary for arc welding at minimum cost.

There are two general types of arc welding machines :

(a) d.c. welding machines

- (i) motor-generator set
- (ii) a.c. transformers with rectifiers

(b) a.c. welding machines

V-I Characteristics of Arc Welding DC Machines

It is found that during welding operation, large fluctuations in current and arc voltage result from the mechanism of metal transfer and other factors. The welding machine must compensate for such changes in arc voltage in order to maintain an even arc column. There are three major voltage/ current characteristics used in modern d.c. welding machines which help in controlling these current fluctuations :

1. drooping arc voltage (DAV).
2. constant arc voltage (CAV).
3. rising arc voltage (RAV).

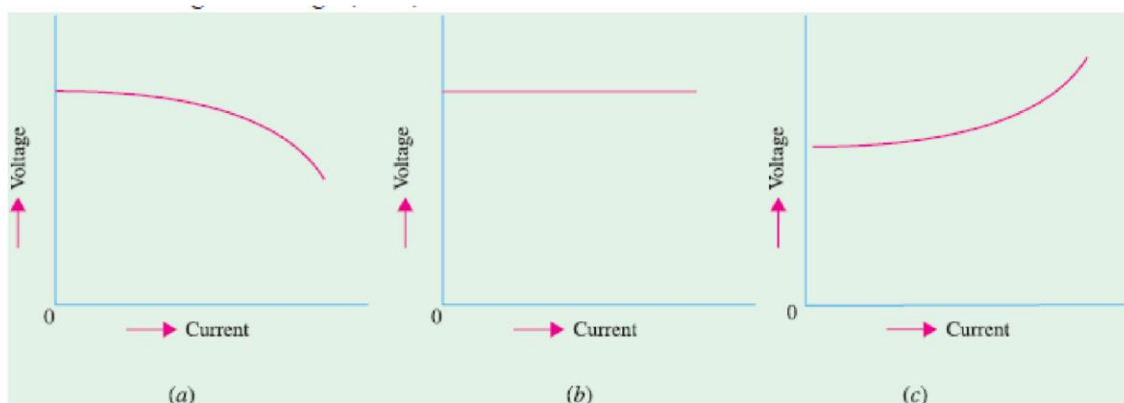

Fig 1.31

The machines with DAV characteristics have high open-circuit voltage which drops to a minimum when arc column is started. The value of current rises rapidly as shown in Fig. 1.31(a).

This type of characteristic is preferred for manual shield metal arc welding.

The CAV characteristic shown in Fig. 1.31 (b) is suitable for semi-automatic or automatic welding processes because voltage remains constant irrespective of the amount of current drawn. Because of its rising voltage characteristic, RAV has an advantage over CAV because it maintains a constant arc gap even if short circuit occurs due to metal transfer by the arc. Moreover, it is well adapted to fully automatic process. DC welding machines can be controlled by a simple rheostat in the exciter circuit or by a combination of exciter regulator and series of field taps. Some arc welding are equipped with remote-controlled current units enabling the operator to vary voltage amperage requirement without leaving the machines.

DC Welding Machines with Motor Generator Set

Such a welding plant is a self-contained single-operator motor-generator set consisting of a reverse series winding d.c. generator driven by either a d.c. or an a.c. motor (usually 3-phase). The series winding produces a magnetic field which opposes that of the shunt winding. On open-circuit, only shunt field is operative and provides maximum voltage for striking the arc. After the arc has been established, current flows through the series winding and sets up a flux which opposes the flux produced by shunt winding. Due to decreases in the net flux, generator voltage is decreased (Art. 1.33). With the help of shunt regulator, generator voltage and current values can be adjusted to the desired level. Matters are so arranged that despite changes in arc voltage due to variations in arc length, current remains practically constant. Fig. 1.32 shows the circuit of a d.c. motor-generator type of welding machine.

Advantages. Such a d.c. welder has the following advantages :

1. It permits portable operation.
2. It can be used with either straight or reverse polarity.
3. It can be employed on nearly all ferrous and non-ferrous materials.
4. It can use a large variety of stick electrodes.
5. It can be used for all positions of welding.

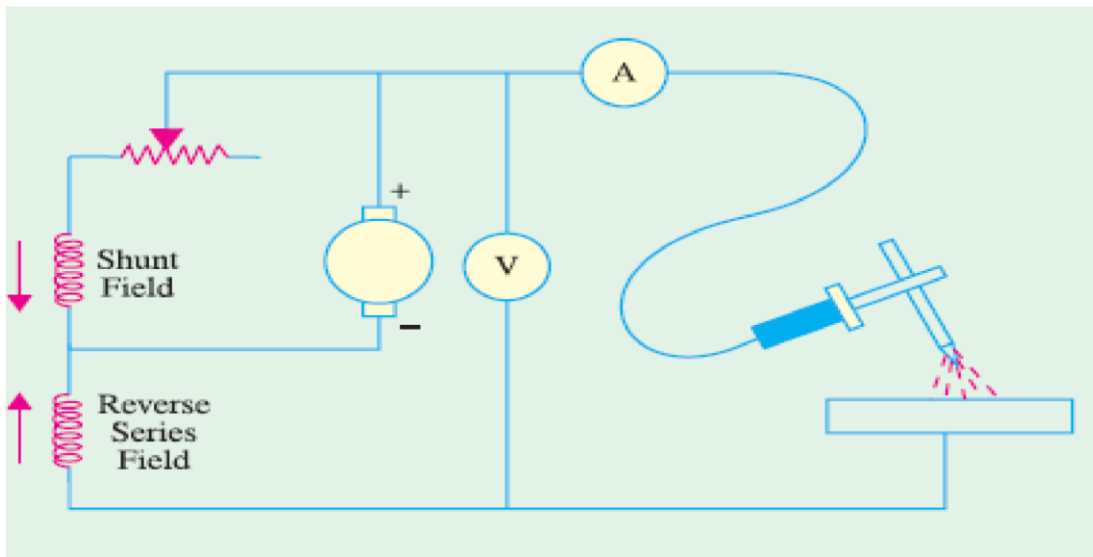

Fig 1.32

Disadvantages

1. It has high initial cost.
2. Its maintenance cost is higher.
3. Machine is quite noisy in operation.
4. It suffers from arc blow.

AC Rectified Welding Unit

It consists of a transformer (single-or three-phase) and a rectifier unit as shown in Fig. 1.33. Such a unit has no moving parts, hence it has long life. The only moving part is the fan for cooling the transformer. But this fan is not the basic part of

the electrical system. Fig. 1.33 shows a single-phase full-wave rectified circuit of the welder. Silicon diodes are used for converting a.c. into d.c. These diodes are hermetically sealed and are almost ageless because they maintain rectifying characteristics indefinitely. Such a transformer-rectifier welder is most adaptable for shield arc welding because it provides both d.c. and a.c. polarities. It is very efficient and quiet in operation. These welders are particularly suitable for the welding of *(i)* pipes in all positions *(ii)* non-ferrous metals *(iii)* low-alloy and corrosion- heat and creep-resisting steel *(iv)* mild steels in thin gauges.

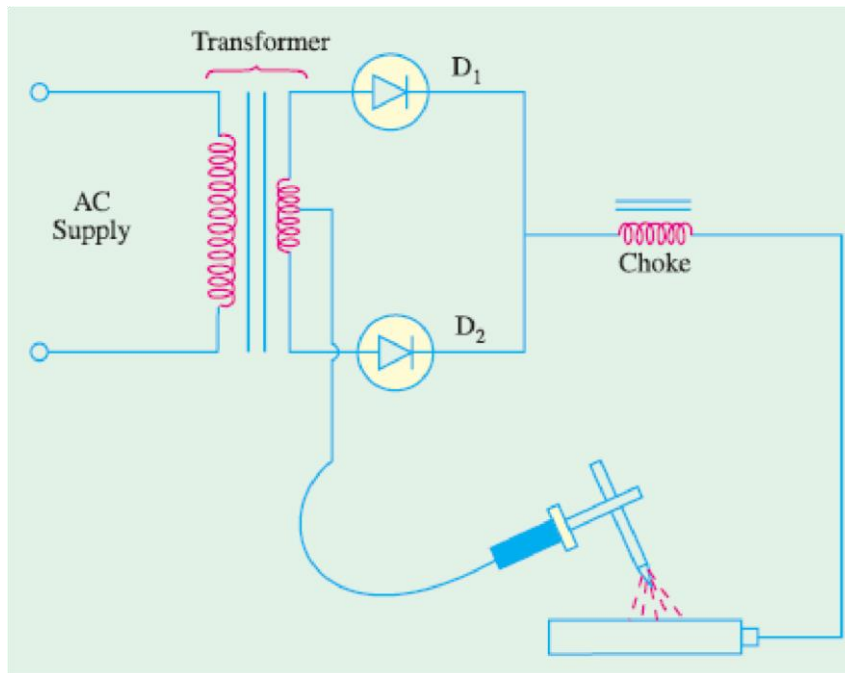

Fig 1.33

AC Welding Machines

As shown in Fig. 1.34, it consists of a step-down transformer with a tapped secondary having an adjustable reactor in series with it for obtaining drooping V/I characteristics. The secondary is tapped to give different voltage/ current settings.

Advantages. This a.c. welder which can be operated from either a single-phase or 3-phase supply has the following advantages : (i) Low initial cost (ii) Low operation and maintenance cost (iii) Low wear (iv) No arc blow

Disadvantages. (i) its polarity cannot be changed (ii) it is not suitable for welding of cast iron and non-ferrous metals.

Duty Cycle of a Welder

The duty cycle of an arc welder is based on a working period of 10 minutes. For example, if a welder is operated for 2 minutes in a period of 10 minutes, then its percentage duty cycle is $(2/10) \times 100 = 20$ percent. Conversely, a 10 percent duty cycle would mean that the welder would

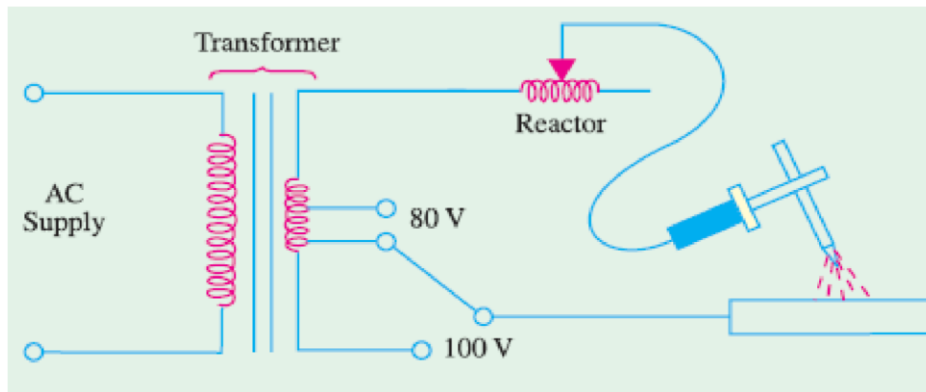

Fig1.34

be operated for 10 percent of 10 minutes *i.e.* for one minute only in a period of 10 minutes. Usually, values of maximum amperage and voltage are indicated along with the duty cycle. It is advisable to adhere to these values. Suppose a welding machine has maximum amperage of 300A and voltage of 50 V for a duty cycle of 60 percent. If this machine is operated at higher settings and for periods longer than 6 minutes, then its internal insulation will deteriorate and cause its early failure

Carbon Arc Welding

(a) General

Carbon arc welding was the first electric welding process developed by a French inventor Auguste de Meritens in 1881. In this process, fusion of metal is accomplished by the heat of an electric arc. No pressure is used and generally, no shielding atmosphere is utilized. Filler rod is used only when necessary. Although not used extensively these days, it has, nevertheless, certain useful fields of application.

Carbon arc welding differs from the more common shield metal arc welding in that *it uses nonconsumable carbon or graphic electrodes* instead of the consumable flux-coated electrodes.

(b) Welding Circuit

The basic circuit is shown in Fig. 48.15 and can be used with d.c. as well as a.c. supply. When direct current is used, the electrode is mostly negative (DCSP). The process is started by adjusting the amperage on the d.c. welder, turning welder ON and bringing the electrode into contact with the workpiece. After the arc column starts, electrode is withdrawn 25 – 40 mm away and the arc is maintained at this distance. The arc can be extinguished by simply removing the electrode from the

workpiece completely. The only function of the carbon arc is to supply heat to the base metal. This heat is used to melt the base metal or filler rod for obtaining fusion weld. Depending on the type and size of electrodes, maximum current values range from 15 A to 600 A for single-electrode carbon arc welding.

(c) Electrodes

These are made of either carbon or graphite, are usually 300 mm long and 2.5 – 12mm in diameter. Graphite electrodes are harder, more brittle and last longer than carbon electrodes. They can withstand higher current densities but their arc column is harder to control. Though considered nonconsumable, they do disintegrate gradually due to vaporisation and oxidation.

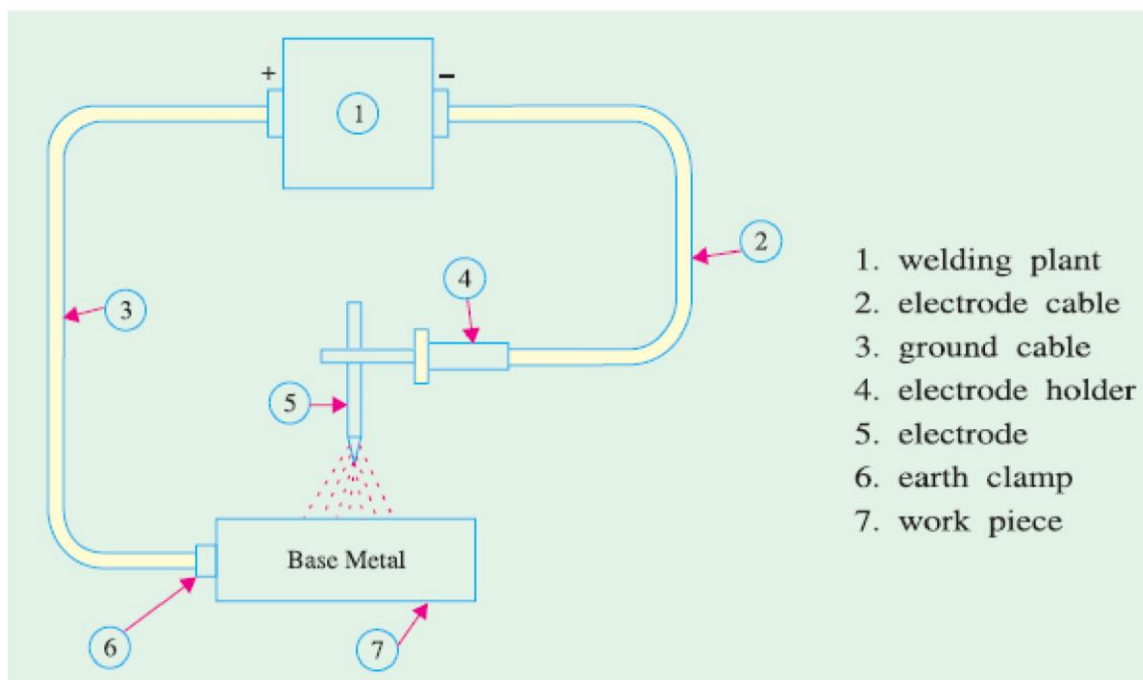

Fig1.35

(d) Applications

1. The joint designs that can be used with carbon arc welding are butt joints, bevel joints, flange joints, lap joints and fillet joints.
2. This process is easily adaptable for automation particularly where amount of weld deposit is large and materials to be fabricated are of simple geometrical shapes such as water tanks.
3. It is suitable for welding galvanised sheets using copper-silicon-manganese alloy filler metal.
4. It is useful for welding thin high-nickel alloys.
5. Monel metal can be easily welded with this process by using a suitable coated filler rod.
6. Stainless steel of thinner gauges is often welded by the carbon-arc process with excellent results.

(e) Advantages and Disadvantages

1. The main advantage of this process is that the temperature of the molten pool can be easily controlled by simply varying the arc length.
2. It is easily adaptable to automation.
3. It can be easily adapted to inert gas shielding of the weld and
4. It can be used as an excellent heat source for brazing, braze welding and soldering etc.

Its disadvantages are as under:

1. A separate filler rod has to be used if any filler material is required.
2. Since arc serves only as a heat source, it does not transfer any metal to help reinforce the weld joint.
3. The major disadvantage of the carbon-arc process is that blow holes occur due to magnetic arc blow especially when welding near edges of the workpiece.

Submerged Arc Welding

In this *fusion* process, welding is done under a blanket of granulated flux which shields the weld from all bad effects of atmospheric gases while a consumable electrode is continuously and mechanically fed into the arc. The arc, the end of the bare metal electrode and the molten weld pool are all submerged under a thick mound of finely-divided granulated powder that contains deoxidisers, cleansers and other fluxing agents. The fluxing powder is fed from a hopper that is carried on the welding head itself (Fig. 1.36). This hopper spread the powder in a continuous mound ahead of the

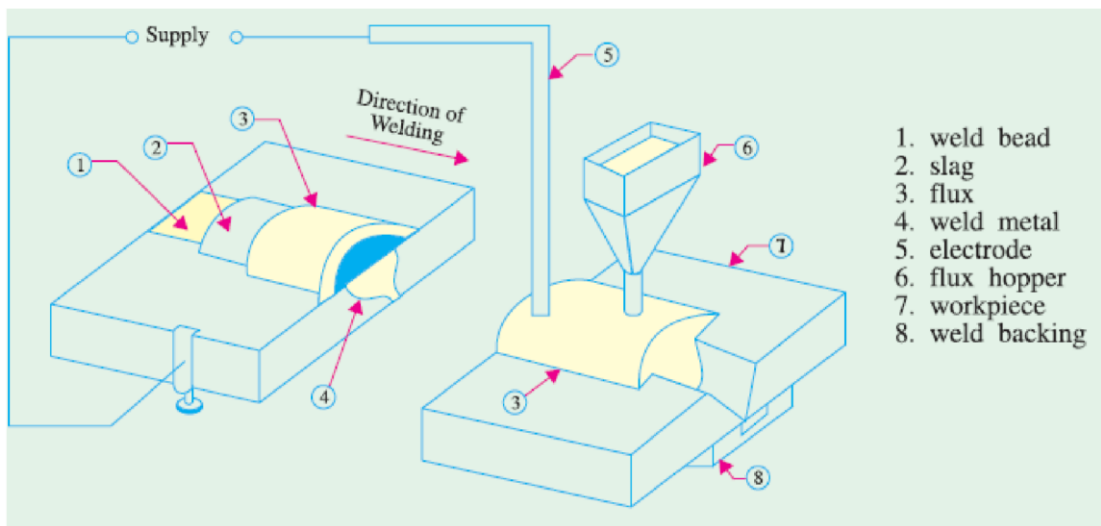

Fig 1.36

electrode in the direction of welding. Since arc column is completely submerged under the powder, there is no splatter or smoke and, at the same time, weld is completely protected from atmospheric contamination. Because of this protection, weld beads are extremely smooth. The flux adjacent to the arc column melts and floats to the top of the molten pool where it solidifies to form slag. This slag is easy to remove. Often it cracks off by itself as it cools. The unused flux is removed and is reused again and again.

The electrode is either a bare wire or has a slight mist of copper coated over it to prevent oxidation. In automatic or semi-automatic submerged arc welding, wire electrode is fed mechanically through an electrically contacting collet. Though a.c. power supply may be used, yet d.c. supply is more popular because it assures a simplified and positive control of the welding process.

This process requires high current densities about 5 to 6 times of those used in ordinary manual stick electrode welding. As a result, melting rate of the electrode as well as welding speed become much higher. Faster welding speed minimizes distortion and warpage. The submerged arc process is suitable for

1. Welding low-alloy, high-tensile steels.
2. Welding mild, low-carbon steels.
3. Joining medium-carbon steel, heat-resistant steels and corrosion-resistant steels etc.
4. Welding nickel, Monel and other non-ferrous metals like copper.

This process has many industrial applications such as fabrication of pipes, boiler pressure vessels, railroad tank cars, structural shapes etc. which demand welding in a straight line. Welds

made by this process have high strength and ductility. A major advantage of this process is that fairly thick sections can be welded in a single pass without edge preparation.

Submerged arc welding can be done manually where automatic process is not possible such as on curved lines and irregular joints. Such a welding gun is shown in Fig. 1.37. Both manual and automatic submerged arc processes are most suited for flat and slightly downhill welding positions.

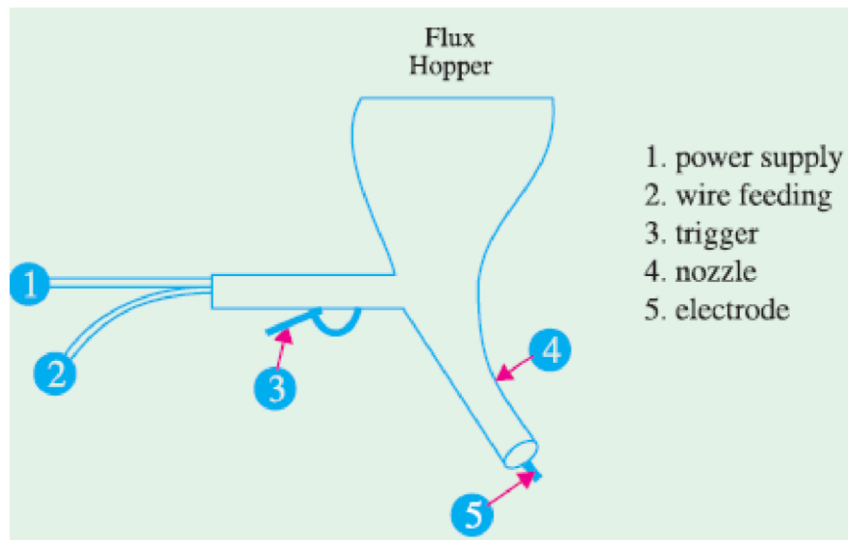

Fig 1.37

Twin Submerged Arc Welding

As shown in Fig. 1.38 in this case, two electrodes are used simultaneously instead of one. Hence, weld deposit size is increased considerably. Moreover, due to increase in welding current (upto 1500 A), much deeper penetration of base metal is achieved.

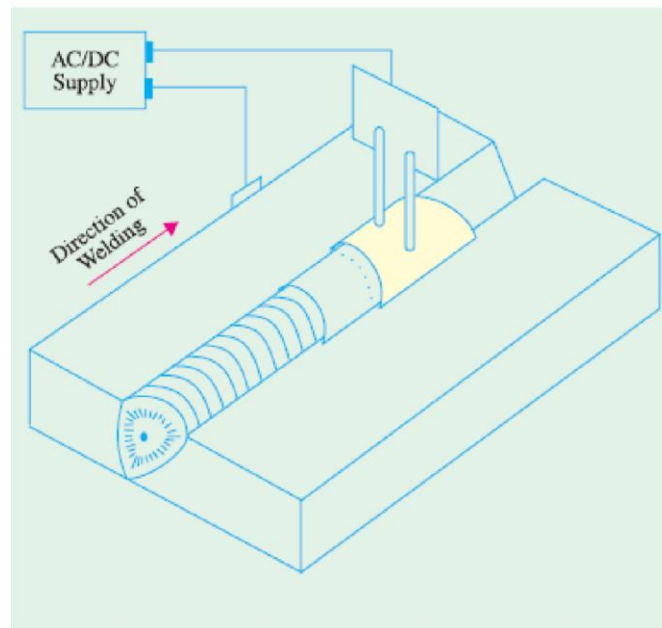

Fig1.38

Gas Shield Arc Welding

In this fusion process, welding is done with bare electrodes but weld zone is shielded from the atmosphere by a gas which is piped to the arc column. Shielding gases used are carbon dioxide, argon, helium, hydrogen and oxygen. No flux is required. Different processes using shielding gas are as follows.

(a) Tungsten inert-gas (TIG) Process

In this process, non-consumable tungsten electrode is used and filler wire is fed separately. The weld zone is shielded from the atmosphere by the inert gas (argon or helium) which is ducted directly to the weld zone where it surrounds the tungsten and the arc column.

(b) Metal inert-gas (MIG) Process

It is a refinement of the TIG process. It uses a bare consumable (*i.e.* fusible) wire electrode which acts as the source for the arc column as well as the supply for the filler material. The weld zone is shielded by argon gas which is ducted directly to the electrode point.

TIG Welding

(a) Basic Principle

It is an electric process which uses a bare non-consumable tungsten electrode for striking the arc only (Fig. 48.19). Filler material is added separately. It uses an inert gas to shield the weld

puddle from atmospheric contamination. This gas is ducted directly to the weld zone from a gas cylinder.

(b) Welding Equipment

The usual TIG welding system consists of the following (Fig. 48.20).

1. A standard shield arc welding machine complete with cables etc.
2. A supply of inert gas complete with hose, regulators etc.
3. A source of water supply (in the case of water-cooled torches).
4. A TIG torch with a control switch to which all the above are connected.

(c) Electrodes

The electrodes are made of either pure tungsten or zirconiated or thoriated tungsten.

Addition of zirconium or thorium (0.001 to 2%) improves electron emission tremendously.

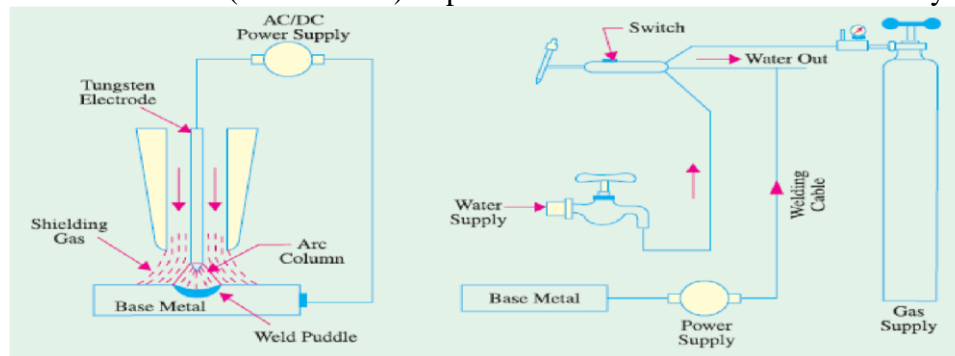

Fig 1.39

(d) Power Supply

The three basic power supplies used in TIG operation are :

1. DCSP power supply—here electrode is negative, runs cooler and, hence, can be thin.
2. DCRP power supply—here electrode is positive and hot. Hence, it has to be large.
3. A.C. high frequency (ACHF) power supply—it is a combination of standard a.c. supply of 50 Hz and high-voltage high-frequency d.c. supply. The function of this d.c. supply is to sustain the arc when a.c. supply

is at zero current positions.

(e) Advantages of TIG Welding

1. It provides maximum protection to weld bead from atmospheric contamination.

2. TIG welds are stronger, more ductile and more corrosion-resistant than those of shield metal arc welding.
3. Since no flux is used, there is no flux entrapment in the bead.
4. Since no flux is required, a wider variety of joint designs can be used.
5. No post-weld cleansing is necessary.
6. There is no weld splatter or sparks that could damage the surface of the base metal.
7. It gives relatively fast welding speeds.
8. It is suitable for welding food or medical containers where entrapment of any decaying organic matter could be extremely harmful.
9. It is suitable for all welding positions—the flat, horizontal, vertical and overhead positions.

The joints suitable for TIG welding process are (i) butt joint (ii) lap joint (iii) T-joint, (iv) corner joint and (v) edge joint.

(f) Applications

1. Aluminum and its alloys — AC/DCRP
2. Magnesium and its alloys — ACHF
3. Stainless steel — DCSP
4. Mild steel, low-alloy steel, medium — DCSP -carbon steel and cast iron — DCSP
5. Copper and alloys — DCSP
6. Nickel and alloys — DCSP

TIG welding is also used for dissimilar metals, hard facing and surfacing of metals. Special industrial applications include manufacture of metal furniture and air-conditioning equipment.

Fig. 1.40 shows Phillips 400-D compact fan-cooled DC TIG welding set which has an open-circuit voltage of 80 V and a welding current of 400 A with 60% duty cycle and 310 A with 100% duty cycle.

MIG Welding

(a) Basic Principle

It is also called inert-gas consumable- electrode process. The fusible wire electrode is driven by the drive wheels. Its function is two-fold: to produce arc column and to provide filler material. This process uses inert gas for shielding the weld zone from atmospheric contamination. Argon is used to weld non-ferrous metals though helium gives better control of porosity and arc stability. This



Fig 1.40

process can deposit large quantities of weld metal at a fast welding speed. The process is easily adaptable to semi-automatic or fully automatic operations.

(b) Welding Equipment

The basic MIG welding system (Fig. 1.43) consists of the following :

1. Welding power supply
2. Inert gas supply with a regulator and flow meter
3. Wire feed unit containing controls for wire feed, gas flow and the ON/OFF switch for MIG torch
4. MIG torch
5. Depending on amperage, a water cooling unit.

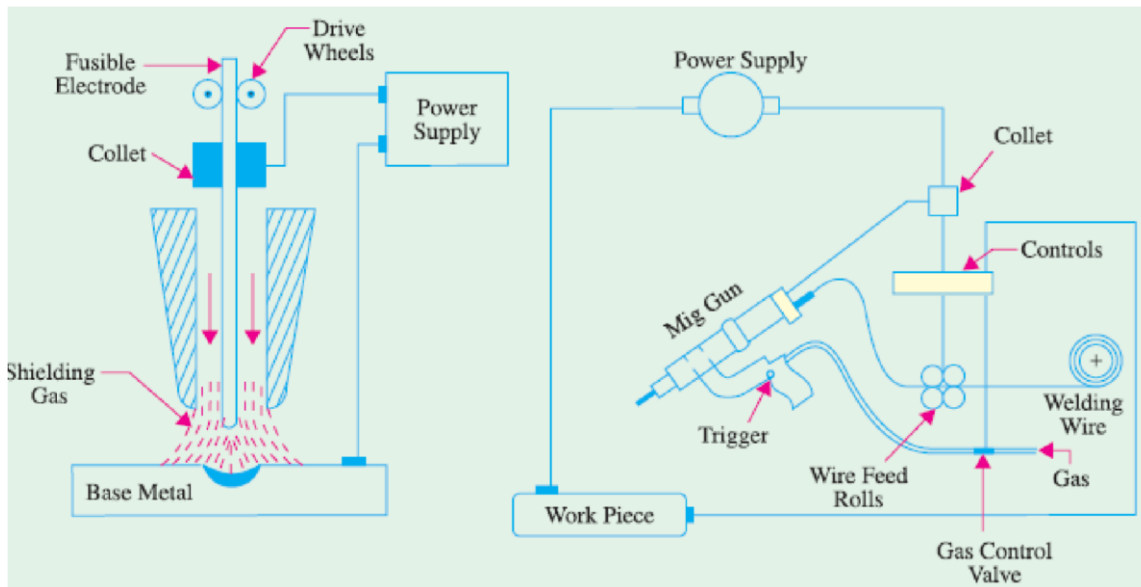

Fig 1.42

(c) Electrode

It is a bare wire fed to the MIG gun by a suitable wire-feed mechanism.

(d) Power Supply

The major power supply used for MIG welding is DCRP and the machines which provide this supply are motor-generator sets or a.c. transformers with rectifiers (Art. 1.44). They have either CAV or RAV characteristics (Art. 1.42). The CAV supply gives the operator great latitude in arc length and is helpful in preventing the wire electrode from stubbing. A DCRP current produces deeper penetration and a cleaner weld surface than other types of current. The RAV machines are more suitable for automatic operation. They are capable of handling large diameter wires than CAV machines. Fig. 1.44 shows semi-automatic forced-air cooled arc welding set MIG-400. It consists of (i) Indarc 400 MMR rectifier which is basically a 3-phase transformer rectifier with silicon



Fig. 48.24.

MIG-400 Welding Set. (Courtesy : Indian Oxygen Ltd. Calcutta)

diodes and a constant potential output. It provides maximum current of 400 A at 40 V for 75% duty cycle and 350 A at 42 V for 100% duty cycle.

- (ii) Indarc Wire Feeder which has a twin roll drive system, designed to feed 0.8 to 2.4 mm diameter welding wires to a hand-operated MIG welding torch.
- (iii) MIG Torches which are available in both air-cooled and water-cooled varieties. Fig. 1.45(a) and (b) show light-weight swan-necked torches which are designed to operate upto 360 A and 400 A with CO₂ as shielding gas. Fig. 48.25 (c) shows a heavy-duty water-cooled torch designed to operate upto 550 A with CO₂ /mixed shielding gases at 100% duty cycle.
- (iv) CO₂ Kit for hard wire applications and Argon Kit for soft wire applications.

(e) Advantages of MIG Welding

1. Gives high metal deposit rates varying from 2 to 8 kg/h.
2. Requires no flux.
3. Requires no post-welding cleaning.
4. Gives complete protection to weld bead from atmospheric contamination.
5. Is adaptable for manual and automatic operations.
6. Can be used for a wide range of metals both ferrous and non-ferrous.
7. Is easy to operate requiring comparatively much less operating skill.
8. Is especially suited for horizontal, vertical and overhead welding positions.

(f) Applications

With inert gas shielding, this process is suitable for fusion welding of (i) aluminium and its alloys (ii) nickel and its alloys (iii) copper alloys (iv) carbon steels (v) low-alloy steels (vi) high strength steels and (vii) titanium.

Atomic Hydrogen Welding

(a) General

It is a non-pressure fusion welding process and the welder set is used only as heat supply for the base metal. If additional metal is required, a filler rod can be melted into the joint. It uses two tungsten electrodes between which an arc column (actually, an arc fan) is maintained by an a.c. supply.

(b) Basic Principle

As shown in Fig. 1.46, an arc column is struck between two tungsten electrodes with an a.c. power supply. Soon after, normal molecular hydrogen (H_2) is forced through this arc column. Due to intense heat of the arc column, this diatomic hydrogen is dissociated into atomic hydrogen (H).

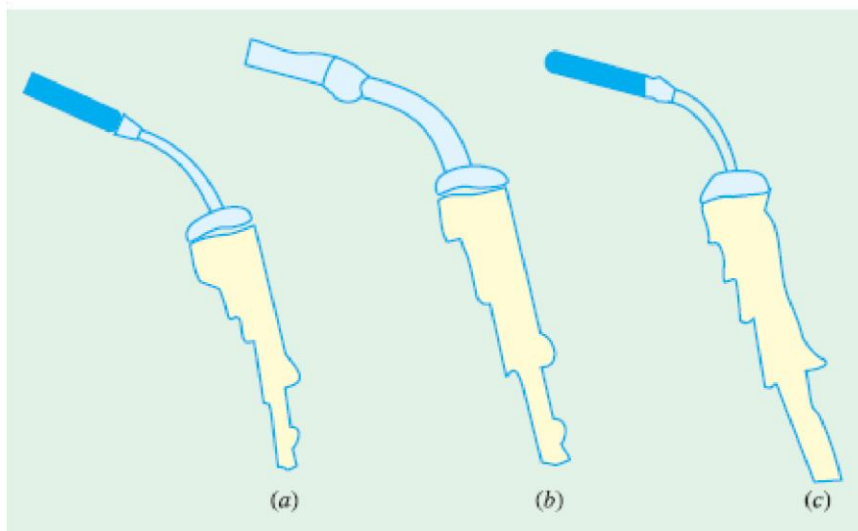

Fig1.45

However, atomic hydrogen being unstable, recombines to form stable molecular hydrogen. In so doing, it releases intense heat at about $3750^{\circ}C$ which is used to fuse the metals.

(c) Welding Equipment

The welding equipment essentially consists of the following :

1. Standard welding machine consisting of a step-down transformer with tapped secondary (not shown in Fig. 48.27) energised from normal a.c. supply. Amperage requirement ranges from 15 A to 150 A
2. Hydrogen gas supply with an appropriate regulator
3. Atomic hydrogen welding torch having an ON-OFF switch and a trigger for moving the two tungsten electrodes close together for striking and maintaining the arc column

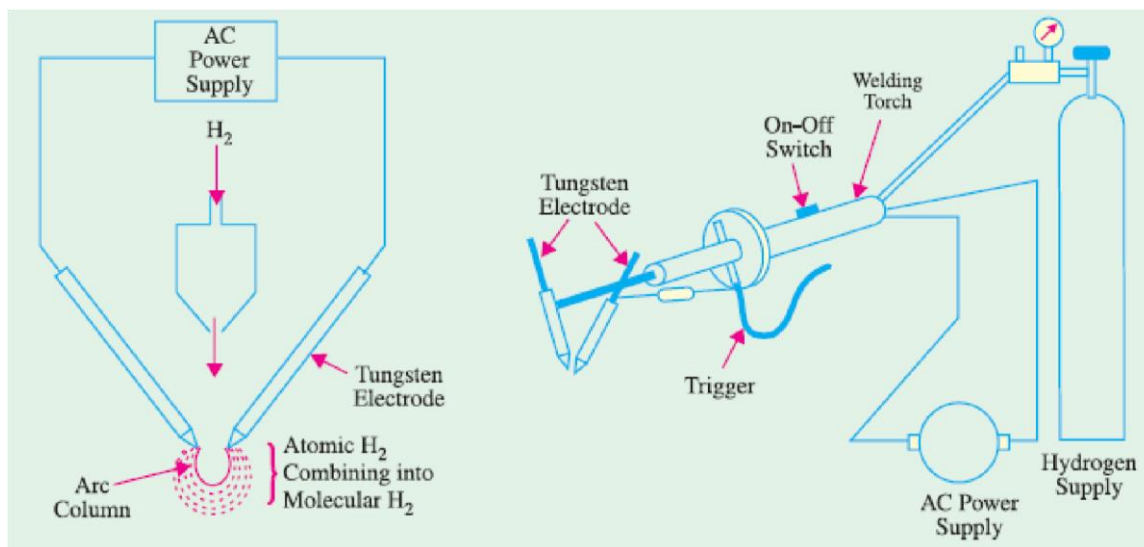

Fig

1.46

(d) Method of Welding

The torch is held in the right hand with first finger resting lightly on the trigger. The arc is struck either by allowing the two tungsten electrodes to touch and separate or by drawing the separated electrodes over a carbon block. At the same time, a stream of hydrogen is allowed to flow through the arc. As soon as the arc strikes, an intensely hot flame extends fanwise between the electrodes.

When this fan touches the workpiece, it melts it down quickly. If filler material is required, it can be added from the rod held in the left hand as in gas welding.

(e) Advantages

1. Arc and weld zone are shrouded by burning hydrogen which, being an active reducing agent, protects them from atmospheric contamination.
2. Can be used for materials too thin for gas welding.
3. Can weld quite thick sections.
4. Gives strong, ductile and sound welds.
5. Can be used for welding of mild steel, alloy steels and stainless steels and aluminum alloys.
6. Can also be used for welding of most non-ferrous metals such as nickel, monel, brass, bronze, tungsten and molybdenum etc.

Resistance Welding

It is fundamentally a heat and squeeze process. The term '*resistance welding*' denotes a group of processes in which welding heat is produced by the resistance offered to the passage of electric current through the two metal pieces being welded. These processes differ from the fusion processes in the sense that no extra metal is added to the joint by means of a filler wire or electrode. According to Joule's law, heat produced electrically is given by $H = I^2 R t / J$. Obviously, amount of heat produced depends on.

(i) square of the current (ii) the time of current and (iii) the resistance offered.

As seen, in simple resistance welding, high-amperage current is necessary for adequate weld. Usually, R is the contact resistance between the two metals being welded together. The current is passed for a suitable length of time controlled by a timer. The various types of resistance welding processes may be divided into the following four main groups : (i) spot welding (ii) seam welding

(iii) projection welding and (iv) butt welding which could be further subdivided into flash welding, upset welding and stud welding etc.

Advantages

Some of the advantages of resistance welding are as under :

1. Heat is localized where required
2. Welding action is rapid
3. No filler material is needed
4. Requires comparatively lesser skill
5. Is suitable for large quantity production
6. Both similar and dissimilar metals can be welded

7. Parent metal is not harmed 8. Difficult shapes and sections can be welded.

Only disadvantages are with regard to high initial as well as maintenance cost.

It is a form of resistance welding in which the two surfaces are joined by spots of fused metal caused by fused metal between suitable electrodes under pressure.

Spot Welding

The process depends on two factors :

1. Resistance heating of small portions of the two workpieces to plastic state and
2. Application of forging pressure for welding the two workpieces.

Heat produced is $H = I^2 R t / J$. The resistance R is made up of (i) resistance of the electrodes and metals themselves (ii) contact resistance between electrodes and workpieces and (iii) contact resistance between the two workpieces. Generally, contact resistance between the two workpieces is the greatest.

As shown in 1.48 (b), mechanical pressure is applied by the tips of the two electrodes. In fact, these electrodes not only provide the forging pressure but also carry the welding current and concentrate the welding heat on the weld spot directly below them. Fig. 1.48(a) shows diagrammatically the basic parts of a modern spot welding. It consists of a step-down transformer which can supply huge currents (upto 5,000 A) for short duration of time.



The lower arm is fixed whereas the upper one is movable. The electrodes are made of low-resistance, hard-copper alloy and are either air cooled or butt-cooled by water circulating through the rifled drillings in the electrode. Pointed electrodes [Fig. 48.29 (a)] are used for ferrous materials

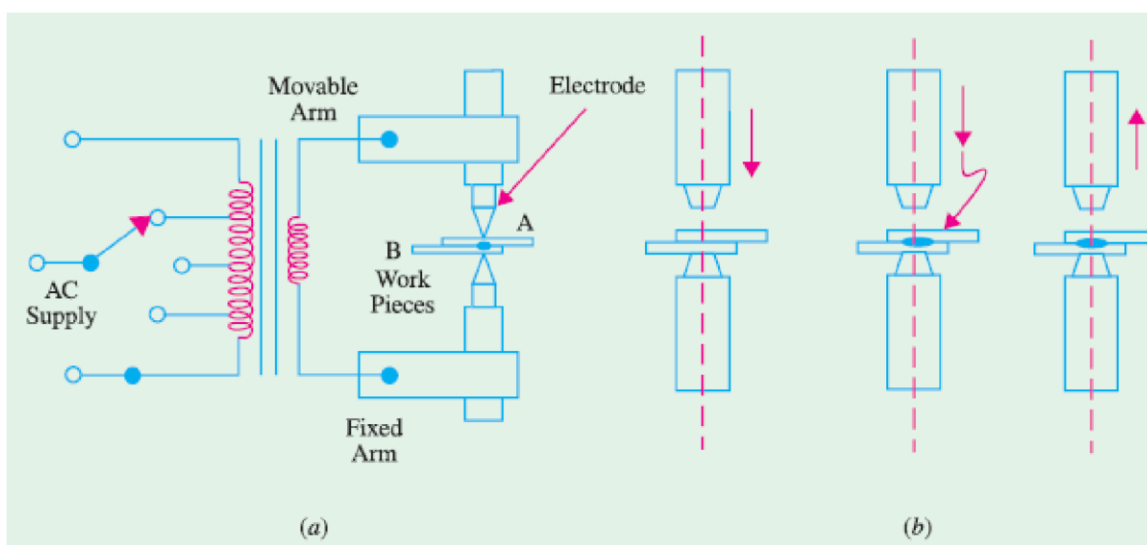

Fig: 1.48

whereas domed electrodes [Fig. 48.25 (b)] are used for non-ferrous materials. Flat domes are used when spot-welding deformation is not desired. The weld size is determined by the diameter of the electrode.

The welding machine is cycled in order to produce the required heat timed to coincide with the pressure exerted by the electrodes as shown in Fig. 48.28 (a). As the movable electrode comes down and presses the two work pieces *A* and *B* together, current is passed through the assembly. The metals under the pressure zone get heated upto about 950°C and fuse together. As they fuse, their resistance is reduced to zero, hence there is a surge of current. This surge is made to switch off the welding current automatically. In motor-driven machines, speeds of 300 strokes minute are common. Spot welders are of two different types. One is a stationary welder which is available in different sizes. The other has a stationary transformer but the electrodes are in a gun form.

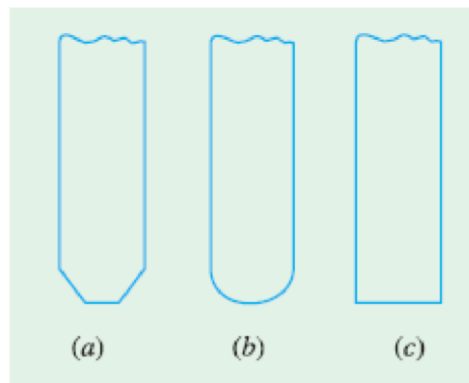
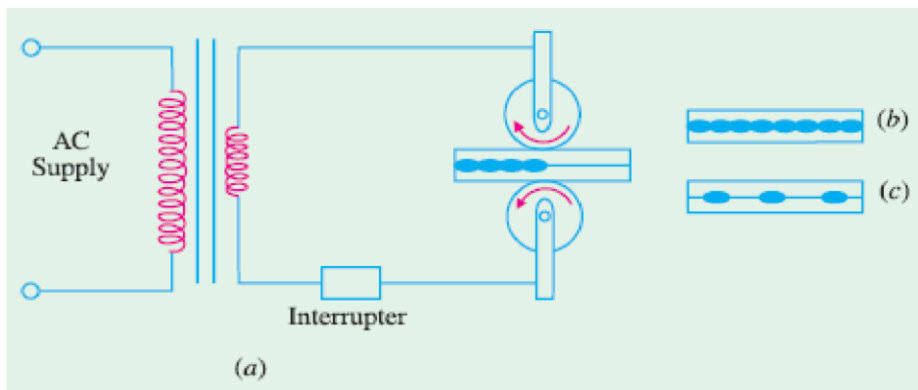

Fig1.49

Electric resistance spot welding is probably the best known and most widely-used because of its low cost, speed and dependability. It can be easily performed by even a semi-skilled operator. This process has a fast welding rate and quick set-up time apart from having low unit cost per weld.

Spot welding is used for galvanized, tinned and leadcoated sheets and mild steel sheet work. This technique is also applied to non-ferrous materials such as brass, aluminium, nickel and bronze etc.



Seam Welding

The seam welder differs from ordinary spot welder only in respect of its electrodes which are of disc or roller shape as shown in Fig. 1.50 (a). These copper wheels are power driven and rotate whilst gripping the work. The current is so applied through the wheels that the weld spots either overlap as in Fig. 48.30 (b) or are made at regular intervals as in Fig. 1.50 (c). The continuous or overlapped seam weld is also called *stitch weld* whereas the other is called roll weld.

Seam welding is confined to welding of thin materials ranging in thickness from 2 mm to 5 mm. It is also restricted to metals having low hardenability rating such as hot-rolled grades of low alloy steels. Stitch welding is commonly used for long water-tight and gas-tight joints. Roll welding is used for simple joints which are not water-tight or gas-tight. Seam welds are usually tested by pillow test.

Projection Welding

It can be regarded as a mass-production form of spot welding. Technically, it is a cross between spot welding and butt welding. It uses the same equipment as spot welding. However, in this process, large-diameter flat electrodes (also called platens) are used. This welding process derives its name from the fact that, prior to welding, projections are raised on the surfaces to be welded [Fig. 1.51(a)]. As seen, the upper and lower platens are connected across the secondary of a step-down transformer and are large enough to cover all the projections to be welded at one stroke of the machine. When platen

A touches the workpiece, welding current flows *through each projection*.

The welding process is started by first lowering the upper platen A on to the work-piece and then applying mechanical pressure to ensure correctly-forged welds. Soon after, welding current

is switched on as in spot welding. As projection areas heat up, they collapse and union takes place at all projections simultaneously [Fig. 48.31 (b)].

It is seen that projections serve many purposes:

1. They increase the welding resistance of the material locally.
2. They accurately locate the positions of the welds.
3. They speed up the welding process by making it possible to perform several small welds simultaneously.
4. They reduce the amount of current and pressure needed to form a good bond between two surfaces.
5. They prolong the life of the electrode considerably because the metal itself controls the heat produced.

Projection welding is used extensively by auto manufactures for joining nuts, bolts and studs to steel plates in car bodies. This process is especially suitable for metals like brass, aluminium and copper etc. mainly due to their high thermal conductivity.

A variation of projection welding is the metal fibre welding which uses a metal fibre rather than a projection point (Fig. 1.52). This metal fibre is generally a felt material. Instead of projections, tiny elements of this felt material are placed between the two metals which are then projection-welded in the usual way

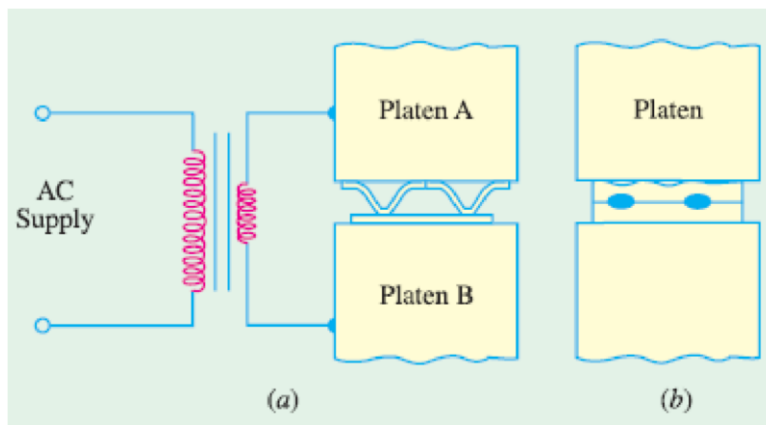

Fig1.51

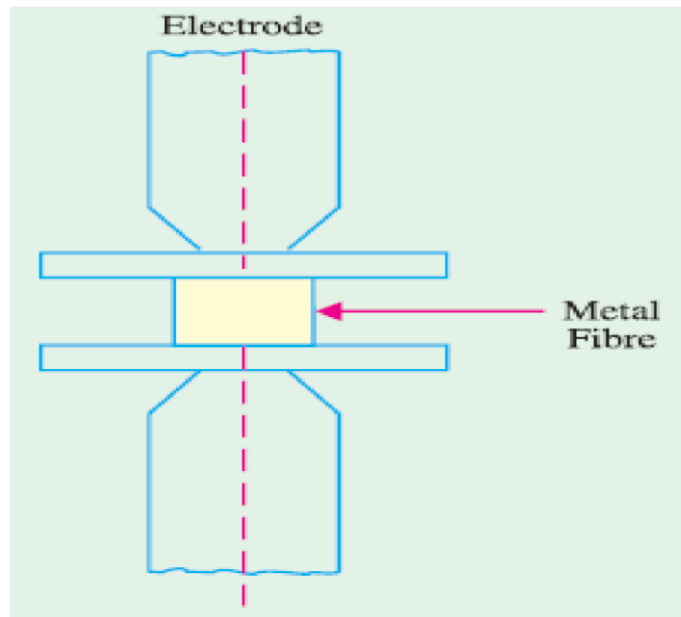

Fig 1.52

Butt Welding

In this case, the two workpieces are brought into contact end-to-end and the butted ends are heated by passing a heavy current through the joint. As in other forms of resistance welding, the weld heat is produced mainly by the electrical resistance of the joint faces. In this case, however, the electrodes are in the form of powerful vice clamps which hold the work-pieces and also convey the forging pressure to the joint [Fig. 1.53].

This process is useful where parts have to be joined end-to-end or edge-to-edge. *i.e.* for welding pipes, wires and rods. It is also employed for making continuous lengths of chain.

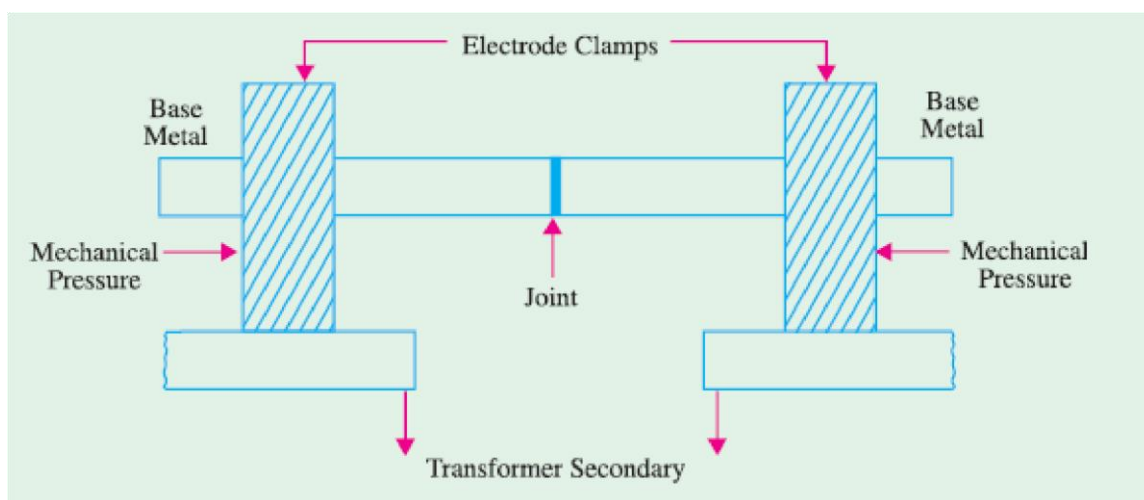

Fig 1.53

Flash Butt Welding

It is also called by the simple name of *flash welding*. It is similar to butt welding but with the difference that here current is applied when ends of the two metal pieces are quite close to each other *but do not touch intimately*. Hence, an arc or flash is set up between them which supplies the necessary welding heat. As seen, in the process heat is applied *before* the two parts are pressed together.

As shown in Fig. 1.54 (a), the workpieces to be welded are clamped into specially designed electrodes one of which is fixed whereas the other is movable. After the flash has melted their faces, current is cut off and the movable platen applies the forging pressure to form a fusion weld. As shown in Fig. 1.54 (b), there is increase in the size of the weld zone because of the pressure which forces the soft ends together

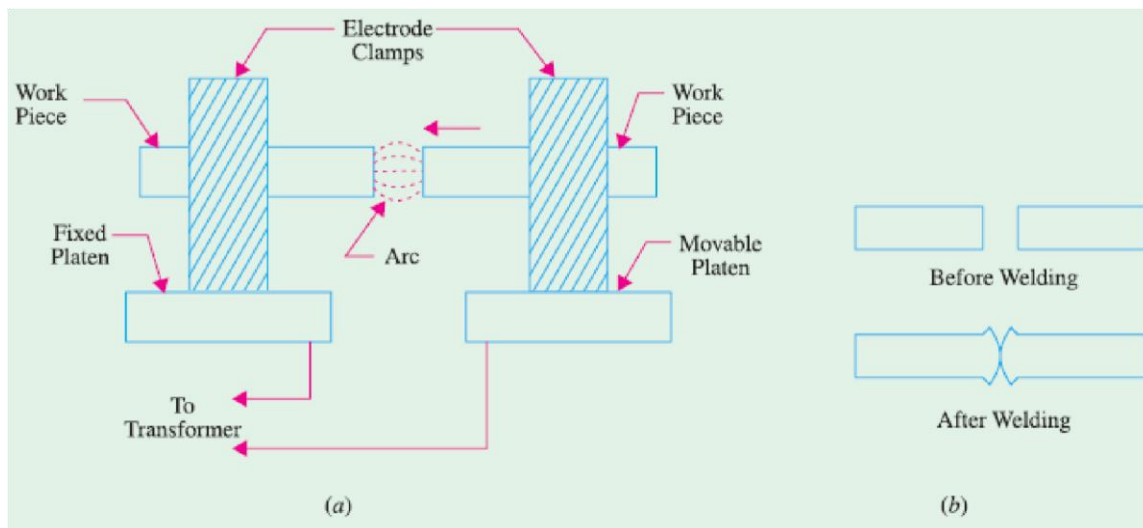

Fig 1.54

Upset Welding

In this process, *no flash is allowed to occur* between the two pieces of the metals to be welded. When the two base metals are brought together to a single interface, heavy current is passed between them which heats them up. After their temperature reaches a value of about 950°C , the two pieces of base metal are pressed together more firmly. This pressing together is called *upsetting*. This upsetting takes place *while current is flowing and continues even after current is switched off*. This upsetting action mixes the two metals homogeneously while pushing out many atmospheric impurities.

Stud Welding

(a) Basic Principle

It is similar to flash welding because it incorporates a method of drawing an arc between the stud (a rod) and the surface of the base metal. Then, the two molten surfaces are brought together under pressure to form a weld. Stud welding eliminates the need for drilling holes in the main structure.

(b) Welding Equipment

The stud welding equipment consists of a stud welding gun, a d.c. power supply capable of giving currents upto 400 A, a device to control current and studs and ferrules which are used not only as arc shields but also as containing walls for the molten metal.

(c) Applications

It is a low-cost method of fastening extensions (studs) to a metal surface. Most of the ferrous and non-ferrous metals can be stud-welded successfully. Ferrous metals include stainless steel, carbon steel and low-alloy steel. Non-ferrous metals include aluminum, lead-free brass, bronze and chrome plated metals.

Stud welding finds application in the installations of conduit pipe hangers, planking and corrugated roofings.

This process is also used extensively in shipbuilding, railroad and automotive industries.

Plasma Arc Welding

(a) Basic Principle

It consists of a high-current electronic arc which is forced through a small hole in a water-cooled metallic nozzle [Fig. 1.55 (a)]. The plasma gas itself is used to protect the nozzle from the extreme heat of the arc. The plasma arc is shielded by inert gases like argon and helium which are pumped through an extra passageway within the nozzle of the plasma torch. As seen, plasma arc consists of electronic arc, plasma gas and gases used to shield the jet column. The idea of using the nozzle is to constrict

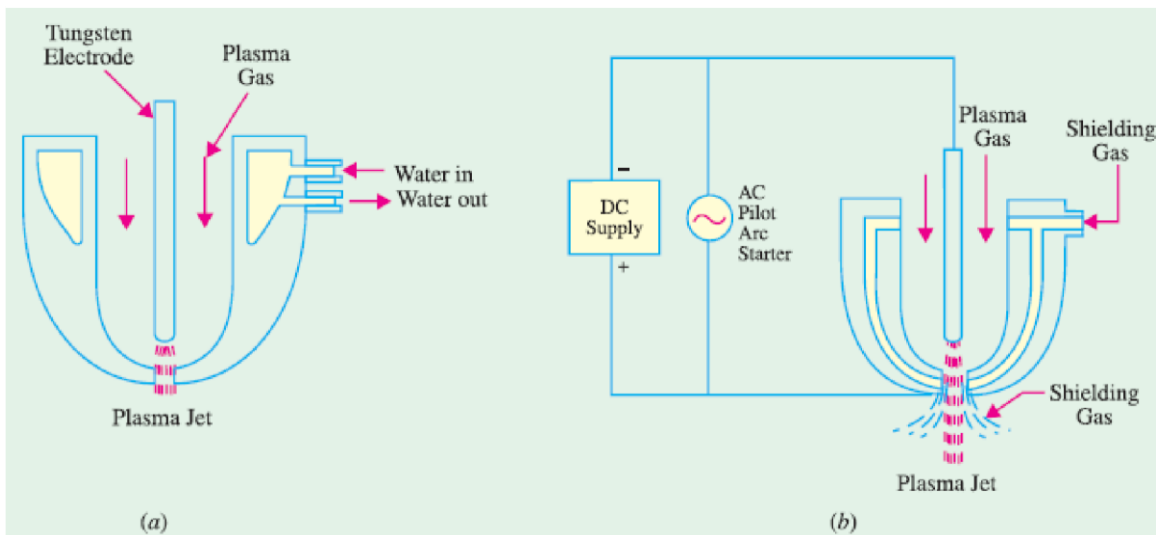

Fig 1.55

the arc thereby increasing its pressure. Collision of high-energy electrons with gas molecules produces the plasma which is swept through the nozzle and forms the current path between the electrode and the workpiece. Plasma jet torches have temperature capability of about $35,000^{\circ}\text{C}$.

(b) Electrodes

For stainless steel welding and most other metals, straight polarity tungsten electrodes are used. But for aluminium welding, reverse polarity water-cooled copper electrodes are used.

(c) Power Supply

Plasma arc welding requires d.c. power supply which could be provided either by a motor-generator set or transformer-rectifier combination. The latter is preferred because it produces better arc stability. The d.c. supply should have an open-circuit voltage of about 70V and drooping voltage-ampere characteristics. A high-frequency pilot arc circuit is employed to start the arc [Fig. 1.55 (b)].

(d) Method of Welding

Welding with plasma arc jet is done by a process called ‘keyhole’ method. As the plasma jet strikes the surface of the workpiece, it burns a hole through it. As the torch progresses along the work-piece, this hole also progresses along with but is filled up by the molten metal as it moves along. Obviously, 100 percent penetration is achieved in this method of welding. Since plasma jet melts a large surface area of the base metal, it produces a weld bead of wineglass design as shown in Fig. 1.56. The shape of the bead can be changed by changing the tip of the nozzle of the torch. Practically, all welding is done mechanically.

(e) Applications

1. Plasma arc welding process has many aerospace applications.
2. It is used for welding of reactive metals and thin materials.
3. It is capable of welding high-carbon steel, stainless steel, maraging steel, copper and copper alloys, brass alloys, aluminium and titanium.
4. It is also used for metal spraying.

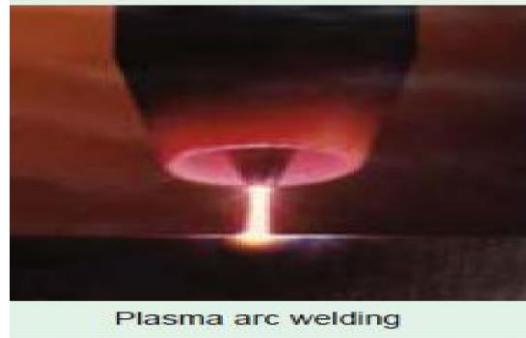

Fig 1.56

5. It can be modified for metal cutting purposes. It has been used for cutting aluminium, carbon steel, stainless steel and other hard-to-cut steels. It can produce high-quality drossfree aluminium cuts 15 cm deep.

(f) Disadvantages

1. Since it uses more electrical equipment, it has higher electrical hazards.
2. It produces *ultra-violet and infra-red* radiations necessitating the use of tinted lenses.
3. It produces high-pitched noise (100 dB) which makes it necessary for the operator to use ear plugs.
5. It can be modified for metal cutting purposes. It has been used for cutting aluminium, carbon steel, stainless steel and other hard-to-cut steels. It can produce high-quality drossfree aluminium cuts 15 cm deep.

(f) Disadvantages

1. Since it uses more electrical equipment, it has higher electrical hazards.
2. It produces *ultra-violet and infra-red* radiations necessitating the use of tinted lenses.
3. It produces high-pitched noise (100 dB) which makes it necessary for the operator to use ear plugs.

Electro slag Welding

(a) General

It is a metal-arc welding process and may be considered as a further development of submerged-arc welding.

This process is used for welding joints of thick sections of ferrous metals in a single pass and without any special joint preparation. Theoretically, there is no upper limit to the thickness of the weld bead. It is usually a vertical uphill process.

It is called *electroslag* process because heat is generated by passing current through the molten slag which floats over the top of the metal.

(b) Welding Equipment

As shown in Fig. 1.57, two water-cooled copper shoes (or dams) are placed on either side of the joint to be welded for the purpose of confining the molten metal in the joint area. The electrode is fed into the weld joint almost vertically from special wire guides. There is a mechanical device which raises the shoes and wire-feed mechanism as the weld continues upwards till it is completed.

An a.c. welding machine has 100 percent duty cycle and which can supply currents upto 1000 A if needed.

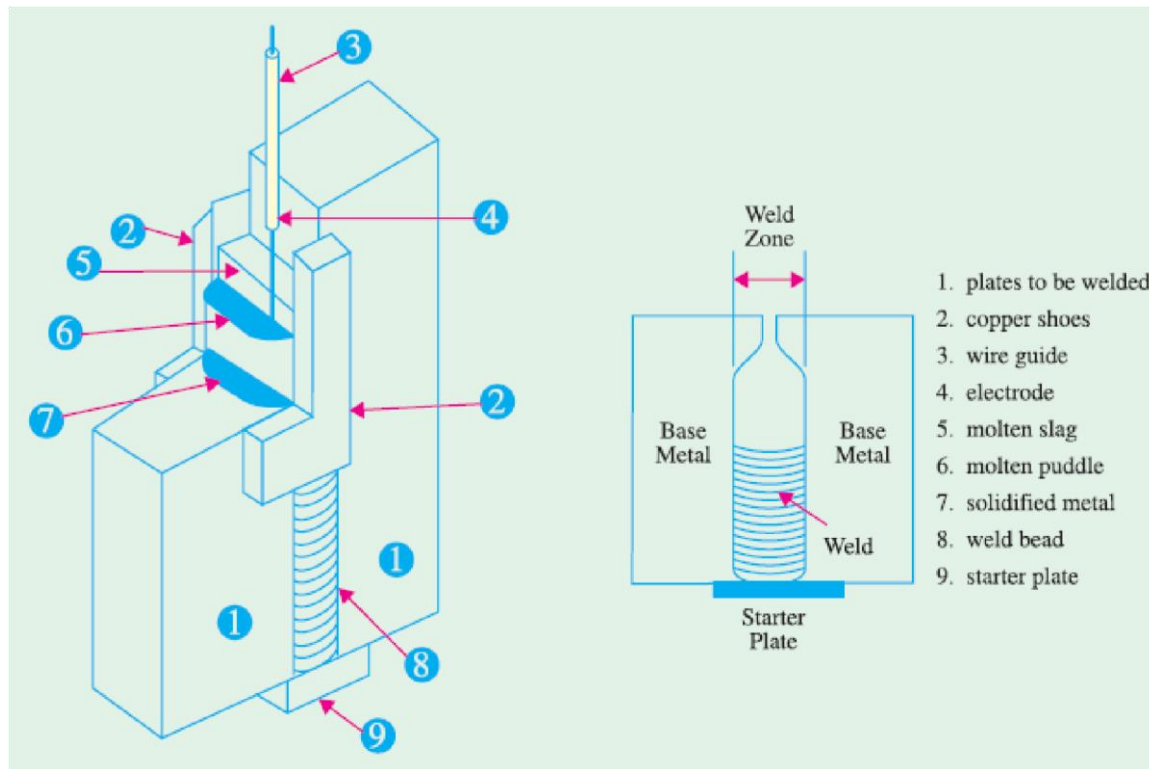

Fig 1.57

(c) Welding Process

The electroslag process is initiated just like submerged arc process by starting an electric arc beneath a layer of granular welding flux. When a sufficient thick layer of hot flux or molten slag is formed, arc action stops and from then onwards, current passes from the electrode to workpiece through the molten slag. At this point, the process becomes truly electroslag welding. A starting plate is used in order to build up proper depth of conductive slag before molten pool comes in contact with the work pieces.

The heat generated by the resistance to the flow of current through the molten slag is sufficient to melt the edges of the workpiece and the filler electrode. The molten base metal and filler metal collect at the bottom of the slag pool forming the weld pool. When weld pool solidifies, weld bead is formed which joins the faces of the base metal as shown in Fig. 1.53 (b).

As welding is continued upwards, flux flows to the top in the form of molten slag and cleanses the impurities from the molten metal. A mechanism raises the equipment as the weld is completed in the uphill vertical position.

(d) Advantages

1. It needs no special joint preparation.
2. It does welding in a single pass rather than in costly multiple passes.

3. There is theoretically no maximum thickness of the plate it can weld.
4. There is also no theoretical upper limit to the thickness of the weld bead. Weld beads upto 400 mm thick have been performed with the presently-available equipment.
5. This process requires less electrical power per kg of deposited metal than either the submerged arc welding process or the shield arc process.
6. It has high deposit rate of upto 20 kg of weld metal per hour.
7. It has lower flux consumption.
8. Due to uniform heating of the weld area, distortion and residual stresses are reduced to the minimal amounts.

However, for electroslag welding, it is necessary to have only a square butt joint or a square edge on the plates to be welded.

(e) Applications

It is commonly used in the fabrication of large vessels and tanks. Low-carbon steels produce excellent welding properties with this process.

Electro gas Welding

This process works on the same basic principle as the electroslag process but has certain additional features of submerged arc welding. Unlike electroslag process, the electrogas process uses an inert gas for shielding the weld from oxidation and there is a continuous arc (as in submerged arc process) to heat the weld pool.

Electron Beam Welding

In this process, welding operation is performed in a vacuum chamber with the help of a sharply focussed beam of high-velocity electrons. The electrons after being emitted from a suitable electrode are accelerated by the high anode voltage and are then focussed into a fine beam which is finally directed to the workpiece. Obviously, this process needs no electrodes. The

electron beam produces intense local heat which can melt not only the metal but can even boil it. A properly-focussed electron beam can completely penetrate through the base metal thereby creating a small hole whose walls are molten. As the beam moves along the joint, it melts the material coming in contact with it. The molten metal flows back to the previously-melted hole where it fuses to make a perfect weld for the entire depth of penetration.

Electron-beam welding has following Advantages:

1. It produces deep penetration with little distortion.
2. Its input power is small as compared to other electrical welding devices.
3. Electron-beam weld is much narrower than the fusion weld.
4. It is especially suitable for reactive metals which become contaminated when exposed to air because this process is carried out in vacuum.
5. It completely eliminates the contamination of the weld zone and the weld bead because operation is performed in a vacuum chamber.
6. It is especially suited to the welding of beryllium which is being widely used in the fabrication of industrial and aerospace components.
7. Its high deposition rate produces welds of excellent quality with only a single pass.
8. It is the only process which can join high temperature metals such as columbium.

At present, its only serious limitations are that it is extremely expensive and is not available in portable form. However, recently a non-vacuum electron-beam welder has been developed.

Laser Welding

It uses an extremely concentrated beam of coherent monochromatic light *i.e.* light of only one colour (or wavelength). It concentrates tremendous amount of energy on a very small area of the workpiece to produce fusion. It uses solid laser (ruby, sapphire), gas laser (CO₂) and semiconductor laser. Both the gas laser and solid laser need capacitor storage to store energy for later injection into the flash tube which produces the required laser beam.

The gas laser welding equipment consists of (i) capacitor bank for energy storage (ii) a triggering device (iii) a flash tube that is wrapped with wire (iv) lasing material (v) focussing lens and (vi) a worktable that can rotate in the three X, Y and Z directions.

When triggered, the capacitor bank supplies electrical energy to the flash tube through the wire. This energy is then converted into short-duration beam of laser light which is pin-pointed on the workpiece as shown in Fig. 48.38. Fusion takes place immediately and weld is completed fast.

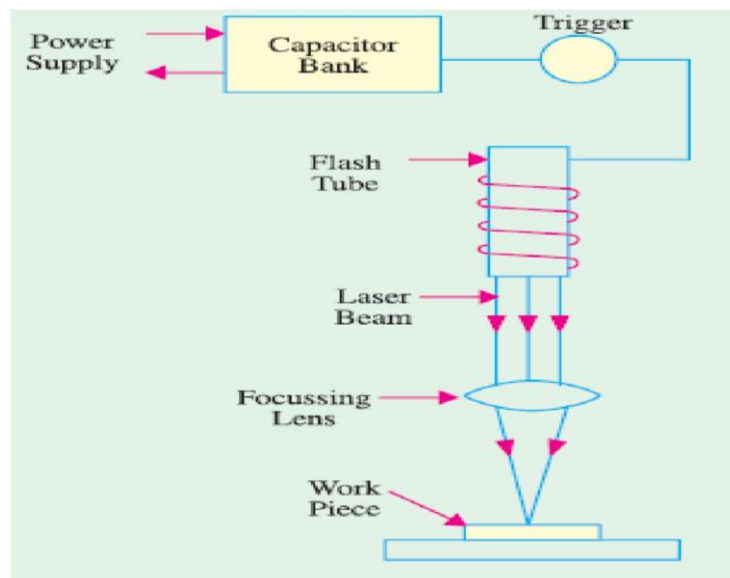

Fig 1.58

Since duration of laser weld beam is very short (2 ms or so), two basic welding methods have been adopted. In the first method, the workpiece is moved so fast that the entire joint is welded in a single burst of the light. The other method uses a number of pulses one after the other to form the weld joint similar to that formed in electric resistance seam welding (Art 1.51).

Laser welding is used in the aircraft and electronic industries for lighter gauge metals.

Some of the advantages of laser welding process are as follows :

1. It does not require any electrode.
2. It can make welds with high degree of precision and on materials as thin as 0.025 mm.
3. It does not heat the workpiece except at one point. In fact, heat-affected zone is virtually nonexistent.
4. Liquidus is reached only at the point of fusion.
5. It can produce glass-to-metal seals as in the construction of klystron tubes.
6. Since laser beam is small in size and quick in action, it keeps the weld zone uncontaminated.
7. It can weld dissimilar metals with widely varying physical properties.
8. It produces minimal thermal distortion and shrinkage because area of heat-affected zone is the minimum possible.
9. It can easily bond refractory materials like molybdenum, titanium and tantalium etc.

However, the major disadvantage of this process is its slow welding speed. Moreover, it is limited to welding with thin metals only.

Expected Questions

1. Explain the properties of good heating element?
2. Define welding, compare resistance and arc welding?
3. A 27kW, 3phase 400V resistance oven is to employ nickel-chrome strip 0.25mm thick for the three star connected heating elements. If the temperature of the strip is to be 1000°C and that of the charge to be 600°C , estimate suitable width for the strip. Assume emissivity=0.9 and radiating efficiency to be 0.5 and resistivity of the strip material is $101.6 \times 10^{-8} \text{ } \Omega\text{-m}$
4. Explain the principles of Induction heating
5. With neat sketch explain the working of a Vertical core type induction furnace.
6. Calculate the efficiency of a high frequency induction furnace which takes 10minutes to melt 1.8kg of aluminium. The input to the furnace is 4.8kW and initial temperature 15°C . Specific heat of aluminium= $0.88\text{kJ/kg }^{\circ}\text{C}$. Melting point of aluminium= 660°C . Latent heat of fusion of aluminium= 32kJ/kg . Assume $1\text{kJ}=2.78 \times 10^{-4}\text{kWh}$.
7. Explain clearly resistance and arc heating?
8. With neat figure, explain vertical core type induction furnace.
9. A cubic water tank has surface area of 6m^2 and is filled to 90% capacity six times daily. The water is heated from 20°C to 65°C . The losses per square metre of tank surface per 1°C temperature difference is 6.3 W. Find the loading kW and the efficiency of the tank. Assume specific heat of water= $4200\text{J/kg}^{\circ}\text{C}$ and $1\text{kWh}=3.6\text{MJ}$.
10. What are the requirements of good welding.
11. Write classification of electric welding.
12. What are the advantages of resistance welding? Explain clearly Butt welding along with its application.
13. Discuss methods of temperature control of resistance oven.
14. Discuss the following applications in dielectric heating. i) Heating of raw plastics ii) Gluing of wood.
15. A cubic water tank has surface area of 5.4m^2 and is filled to 92% capacity five times daily. The water is heated from 15°C to 60°C . The losses per square meter of tank per 1°C temperature difference are 5.9 W. Calculate i) Loading in kW ii) Efficiency of tank. Assume specific heat of water= $4.186\text{kJ/kg}^{\circ}\text{C}$
16. Define the term welding. What is resistance welding? What are its limitations?
17. Compare A.C and D.C welding?
18. Explain the terms i) Anodizing ii) Polarizing with respect to electrolytic process.

Unit 2

Electrolytic Process

Definition of Electrolysis

An electrolyte is such a chemical that's atoms are normally closely bonded together but when it is dissolved in water, its molecules split up into positive and negative ions. The positively charged ions are referred as cations whereas negatively charged ions are referred as anions. Both cations and anions move freely in the solution.

Principle of Electrolysis

As discussed in the definition of electrolyte, whenever any electrolyte gets dissolved in water, its molecules split into cations and anions moving freely in the electrolytic solution. Now two metal rods are immersed in the solution and an electrical potential difference applied between the rods externally preferably by a battery. These partly immersed rods are technically referred as electrodes. The electrode connected with negative terminal of the battery is known as cathode and the electrode connected with positive terminal of the battery is known as anode. The freely moving positively charged cations are attracted by cathode and negatively charged anions are attracted by anode. In cathode, the positive cations take electrons from negative cathode and in anode, negative anions give electrons to the positive anode. For continually taking and giving electrons in cathode and anode respectively, there must be flow of electrons in the external circuit of the electrolytic. That means, electric current continues to circulate around the closed loop created by battery, electrolytic and electrodes. This is the most basic **principle of electrolysis**

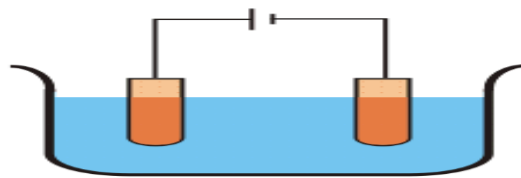

Fig:2.1: Electrolysis process

Electrolysis of Copper Sulfate

Whenever copper sulfate or CuSO_4 is added to water, it gets dissolved in the water. As the CuSO_4 is an electrolyte, it splits into Cu^{++} (cation) and SO_4^{--} (anion) ions and move freely in the solution. Now if two copper electrodes are immersed in that solution, the Cu^{++} ions (cation) will be attracted towards cathode i.e. the electrode connected to the negative terminal of the battery. On reaching on the cathode, each Cu^{++} ion will take electrons from it and becomes neutral copper atoms. Similarly the SO_4^{--} (anion) ions will be attracted by anode i.e. the electrode connected to the positive terminal of the battery. So SO_4^{--} ions will move towards anode where they give up two electrons and become SO_4 radical but since SO_4 radical can not exist in the electrical neutral state, it will attack copper anode and will form copper sulfate. If during **electrolysis of copper sulfate**, we use carbon electrode instead of copper or other metal electrodes, then **electrolysis** reactions will be little bit different. Actually SO_4 can not react with carbon and in this case the SO_4 will react with water of the solution and will form sulfuric acid and liberate oxygen.



The process described above is known as **electrolysis**. In the above process, after taking electrons the neutral copper atoms get deposited on the cathode. At the same time, SO_4 reacts with copper anode and becomes CuSO_4 but in water it can not exist as single molecules instead of that CuSO_4 will split into Cu^{++} , SO_4^{--} and dissolve in water. So it can be concluded that, during electrolysis of copper sulfate with copper electrodes, copper is deposited on cathode and same amount of copper is removed from anode.

Faraday's Laws of Electrolysis

Before understanding **Faraday's laws of electrolysis**, we have to recall the process of electrolysis of a metal sulfate.

Whenever an electrolyte like metal sulfate is diluted in water, its molecules split into positive and negative ions. The positive ions or metal ions move to the electrodes connected with negative terminal of the battery where these positive ions take electrons from it, become pure metal atom and get deposited on the electrode. Whereas negative ions or sulphions move to the electrode connected with positive terminal of the battery where these negative ions give up their extra electrons and become SO_4 radical. Since SO_4 cannot exist in electrically neutral state, it will attack metallic positive electrode and form metallic sulfate which will again dissolve in the water. **Faraday's laws of electrolysis** combine two laws and these are,

Faraday's First Law of Electrolysis

From the brief explanation above, it is clear that the flow of current through the external battery circuit fully depends upon how many electrons get transferred from negative electrode or cathode to positivemetallic ion or cations. If the cations have valency of two like Cu^{++} then for every cation, there would be two electrons transferred from cathode to cation. We know that every electron has negative electrical charge $- 1.602 \times 10^{-19}$ Coulombs and say it is $- e$. So for disposition of every Cu atom on the cathode, there would be $- 2.e$ charge transfers from cathode to cation. Now say for t time there would be total n number of copper atoms deposited on the cathode, so total charge transferred, would be $- 2.n.e$ Coulombs. Mass m of the deposited copper is obviously function of number of atoms deposited. So, it can be concluded that the mass of the deposited copper is directly proportional to the quantity of electrical charge that passes through the electrolyte. Hence mass of deposited copper $m \propto Q$ quantity of electrical charge passes through the electrolyte.

Faraday's First Law of Electrolysis states that only,

According to this law, the chemical deposition due to flow of electric current through an electrolyte is directly proportional to the quantity of electricity (coulombs) passed through it.

i.e. mass of chemical deposition,

$$m \propto \text{Quantity of electricity, } Q \Rightarrow m = Z \cdot Q$$

Where Z is a constant of proportionality and is known as electrochemical equivalent of the substance.

If we put $Q = 1$ coulombs in the above equation, we will get $Z = m$ which implies that electrochemical equivalent of any substance is the amount of the substance deposited on passing of 1 coulomb through its solution. This constant of passing of electrochemical equivalent is generally expressed in terms of milligram per coulomb or kilogram per coulomb.

Faraday's Second Law of Electrolysis

So far we have learned that the mass of the chemical, deposited due to electrolysis is proportional to the quantity of electricity that passes through the electrolyte. The mass of the chemical, deposited due to electrolysis is not only proportional to the quantity of electricity passes through the electrolyte, but it also depends upon some other factor. Every substance will have its own atomic weight. So for same number of atoms, different substances will have different masses. Again, how many atoms deposited on the electrodes also depends upon their number of valency. If valency is more, then for same amount of electricity, number

of deposited atoms will be less whereas if valency is less, then for same quantity of electricity, more number of atoms to be deposited. So, for same quantity of electricity or charge passes through different electrolytes, the mass of deposited chemical is directly proportional to its atomic weight and inversely proportional to its valency.

Faraday's second law of electrolysis states that, when the same quantity of electricity is passed through several electrolytes, the mass of the substances deposited are proportional to their respective chemical equivalent or equivalent weight.

Applications of Electrolysis:

Electrolytic Refining of Metals

The process of **electrolytic refining of metals** is used to extract impurities from crude metals. Here in this process, a block of crude metal is used as anode, a diluted salt of that metal is used as electrolyte and plates of that pure metal is used as cathode.

Electrolytic Refining of Copper

For understanding the process of **electrolytic refining of metals**, we will discuss about an example of **electrolytic refining of copper**. Copper extracted from its ore, known as blister copper, is 98 to 99 % pure but it can easily be made up to 99.95% pure for electrical application by the process of **electrorefining**.

In this process of electrolysis, we use a block of impure copper as anode or positive electrode, copper sulfate acidified with sulfuric acid, electrolyte and pure copper plates coated with graphite, as cathode or negative electrode.

The copper sulfate splits into positive copper ion (Cu^{++}) and negative sulfate ion (SO_4^{--}). The positive copper ion (Cu^{++}) or cations will move towards negative electrode made of pure copper where it takes electrons from cathode, becomes Cu atom and is deposited on the graphite surface of the cathode.

On the other hand, the SO_4^{--} will move towards positive electrode or anode where it will receive electrons from anode and become radical SO_4 but as radical SO_4 can not exist alone, it will attack copper of anode and form CuSO_4 . This CuSO_4 will then dissolve and split in the solution as positive copper ion (Cu^{++}) and negative sulfate ion (SO_4^{--}). These positive copper ions (Cu^{++}) will then move towards negative electrode where it takes electrons from cathode, become Cu atoms and are deposited on the graphite surface of the cathode. In this way, the copper of impure crude will be transferred and deposited on the graphite surface of the cathode. The metallic impurities of anode are also merged with SO_4 , form metallic sulfate and dissolve in the electrolyte solution. The impurities like silver and gold, which are not effected by sulfuric acid-copper sulfate solution, will settle down as the anode sludge or mud. At a regular interval of electrolytic refining of copper, the deposited copper is stripped out from the cathode and anode is replaced by a new block of crude copper.

Electroplating

The process of **electroplating** is theoretically same as electrorefining - only difference is that, in place of graphite coated cathode we have to place an object on which the **electroplating** has to be done. Let's take an example of brass key which is to be copper-plated by using **copper electroplating**.

Copper Electroplating

We have already stated that copper sulfate splits into positive copper ion (Cu^{++}) and negative sulfate ion (SO_4^{--}) in its solution. For **copper electroplating**, we use copper sulfate solution as electrolyte, pure copper as anode and an object (a brass key) as cathode. The pure copper rod is connected with positive terminal and the brass key is connected with negative terminal of a battery. While these copper rod and key are immersed into copper-sulfate solution, the copper rod will behave as anode and the key will behave as cathode. As the cathode or the brass key is connected with negative terminal of battery, it will attract the positive cations or Cu^{++} ions and on reaching of Cu^{++} ions on the surface of the brass key, they will receive electrons from it, become neutral copper atom and are about to be deposited on the surface of the brass key as uniform layer. The sulfate or SO_4^{--} ions move to the anode and extract copper from it into the solution as mentioned in the process of electro-refining. For proper and uniform copper plating, the object (here it is brass key) is being rotated slowly into the solution.

Electroforming

Reproduction of objects by electro-deposition on some sort of mould is known as **electroforming**. This is another very useful example among many applications of electrolysis. For that, first we have to take the impression of objects on wax or on other wax like material. The surface of the wax mold which bears exact impression of the object, is coated with graphite powder in order to make it conducting. Then the mold is dipped into the electrolyte solution as cathode. During electrolysis process, the electrolyte metal will be deposited on the graphite coated impressed surface of the mold. After obtaining a layer of desired thickness, the article is removed and the wax is melted to get the reproduced object in form of metal shell.

A popular use of **electroforming** is reproduction of gramophone record dices. The original recording is done on a record of wax composition. This wax mold is then coated with gold powder to make it conducting. Then this mold is dipped into a blue vitriol electrolyte as cathode. The solution is kept saturated by using a copper anode. The copper electroforming on the wax mold produces master plate which is used to stamp a large number of shellac discs.

Factors affecting Electro deposition Process

Electrophoretic deposition (EPD), is a term for a broad range of industrial processes which includes **electrocoating, e-coating, cathodic electrodeposition, anodic electrodeposition, and electrophoretic coating, or electrophoretic painting**. A characteristic feature of this process is that colloidal particles suspended in a liquid medium migrate under the influence of an electric field (electrophoresis) and are deposited onto an electrode. All colloidal particles that can be used to form stable suspensions and that can carry a charge can be used in electrophoretic deposition. This includes materials such as polymers, pigments, dyes, ceramics and metals.

The process is useful for applying materials to any electrically conductive surface. The materials which are being deposited are the major determining factor in the actual processing conditions and equipment which may be used.

Due to the wide utilization of electrophoretic painting processes in many industries, aqueous EPD is the most common commercially used EPD process. However, non-aqueous electrophoretic deposition applications are known. Applications of non-aqueous EPD are currently being explored for use in the fabrication of electronic components and the production of ceramic coatings. Non-aqueous processes have the advantage of avoiding the electrolysis of water and the oxygen evolution which accompanies electrolysis.

Uses of EPD

This process is industrially used for applying coatings to metal fabricated products. It has been widely used to coat automobile bodies and parts, tractors and heavy equipment, electrical switch gear, appliances, metal furniture, beverage containers, fasteners, and many other industrial products.

EPD processes are often applied for the fabrication of supported titanium dioxide (TiO_2) photocatalysts for water purification applications, using precursor powders which can be immobilised using EPD methods onto various support materials. Thick films produced this way allow cheaper and more rapid synthesis relative to sol-gel thin-films, along with higher levels of photocatalyst surface area.

EPD processed have a number of advantages which have made such methods widely used

1. The process applies coatings which generally have a very uniform coating thickness without porosity.
2. Complex fabricated objects can easily be coated, both inside cavities as well as on the outside surfaces.
3. Relatively high speed of coating.
4. Relatively high purity.
5. Applicability to wide range of materials (metals, ceramics, polymers, etc.)
6. Easy control of the coating composition.
7. The process is normally automated and requires less human labor than other coating processes.
8. Highly efficient utilization of the coating materials result in lower costs relative to other processes.
9. The aqueous process which is commonly used has less risk of fire relative to the solvent-borne coatings that they have replaced.
10. Modern electrophoretic paint products are significantly more environmentally friendly than many other painting technologies.

Process of electrophoretic painting

The overall industrial process of electrophoretic deposition consists of several sub-processes:

1. The object to be coated needs to be prepared for coating. This normally consists of some kind of cleaning process and may include the application of a conversion coating, typically an inorganic phosphate coating.
2. The coating process itself. This normally involves submerging the part into a container or vessel which holds the coating bath or solution and applying direct current electricity through the EPD bath using electrodes. Typically voltages of 25 - 400 volts DC are used in electrocoating or electrophoretic painting applications. The object to be coated is one of the electrodes, and a set of "counter-electrodes" are used to complete the circuit.
3. After deposition, the object is normally rinsed to remove the undeposited bath. The rinsing process may utilize an ultrafilter to dewater a portion of the bath from the coating vessel to be used as rinse material. If an ultrafilter is used, all of the rinsed off materials can be returned to the coating vessel, allowing for high utilization efficiency of the coating materials, as well as reducing the amount of waste discharged into the environment.
4. A baking or curing process is normally used following the rinse. This will [crosslink](#) the polymer and allows the coating, which will be porous due to the evolution of gas during the deposition process, to flow out and become smooth and continuous.

Power Supply for electrolytic process

Electrolysis is a method of using a direct electric current (DC) to drive an otherwise non-spontaneous chemical reaction. Electrolysis is commercially highly important as a stage in the separation of elements from naturally occurring sources such as ores using an electrolytic cell. The voltage that is needed for electrolysis to occur is called decomposition potential.

Electrolysis is the passage of a direct electric current through an ionic substance that is either molten or dissolved in a suitable solvent, resulting in chemical reactions at the electrodes and separation of materials.

The main components required to achieve electrolysis are:

An electrolyte : a substance containing free ions which are the carriers of electric current in the electrolyte. If the ions are not mobile, as in a solid salt then electrolysis cannot occur.

A direct current (DC) supply : provides the energy necessary to create or discharge the ions in the electrolyte. Electric current is carried by electrons in the external circuit.

Two electrodes : an electrical conductor which provides the physical interface between the electrical circuit providing the energy and the electrolyte

Electrodes of metal, graphite and semiconductor material are widely used. Choice of suitable electrode depends on chemical reactivity between the electrode and electrolyte and the cost of manufacture.

Energy changes during electrolysis

The amount of electrical energy that must be added equals the change in Gibbs free energy of the reaction plus the losses in the system. The losses can (in theory) be arbitrarily close to zero, so the maximum thermodynamic efficiency equals the enthalpy change divided by the free energy change of the reaction. In most cases, the electric input is larger than the enthalpy change of the reaction, so some energy is released in the form of heat. In some cases, for instance, in the electrolysis of steam into hydrogen and oxygen at high temperature, the opposite is true. Heat is absorbed from the surroundings, and the heating value of the produced hydrogen is higher than the electric input.

Expected Questions

1. What do you mean by Electrolysis process?
2. Explain the extraction of metals.
3. Define electro chemical equivalent and energy efficiency.
4. State and explain faradays laws of electrolysis.
5. Explain throwing power and polarisation.
6. What do you mean by electro deposition?
7. Explain the factors affecting electro deposition.

UNIT 3 & 4

ILLUMINATION**Radiations From a Hot Body**

The usual method of producing artificial light consists in raising a solid body or vapour to incandescence by applying heat to it. It is found that as the body is gradually heated above room temperature, it begins to radiate energy in the surrounding medium in the form of electromagnetic waves of various wavelengths. The *nature* of this radiant energy depends on the temperature of the hot body. Thus, when the temperature is low, radiated energy is in the form of heat waves only but when a certain temperature is reached, light waves are also radiated out in addition to heat waves and the body becomes luminous. Further increase in temperature produces an increase in the amount of both kinds of radiations but the colour of light or visible radiation changes from bright red to orange, to yellow and then finally, if the temperature is high enough, to white. As temperature is increased, the wavelength of the visible radiation goes on becoming shorter. It should be noted that heat waves are identical to light waves except that they are of longer wavelength and hence produce no impression on the retina. Obviously, from the point of view of light emission, heat energy represents so much wasted energy.

Radiations from a Hot Body

The usual method of producing artificial light consists in raising a solid body or vapour to incandescence by applying heat to it. It is found that as the body is gradually heated above room temperature, it begins to radiate energy in the surrounding medium in the form of electromagnetic waves of various wavelengths. The *nature* of this radiant energy depends on the temperature of the hot body. Thus, when the temperature is low, radiated energy is in the form of heat waves only but when a certain temperature is reached, light waves are also radiated out in addition to heat waves and the body becomes luminous. Further increase in temperature produces an increase in the amount of both kinds of radiations but the colour of light or visible radiation changes from bright red to orange, to yellow and then finally, if the temperature is high enough, to white. As temperature is increased, the wavelength of the visible radiation goes

on becoming shorter. It should be noted that heat waves are identical to light waves except that they are of longer wavelength and hence produce no impression on the retina. Obviously, from the point of view of light emission, heat energy represents so much wasted energy.

$$1 \text{ A.U.} = 10^{-8} \text{ cm} = 10^{-10} \text{ m}$$

Hence, the wave-length of red light becomes $\lambda_r = 7800 \times 10^{-10} \text{ m}$ or 7800 A.U. and $\lambda_v = 3900 \times 10^{-10} \text{ m}$ or 3900 A.U. The sensation of colour is due to the difference in the wavelengths and hence frequencies of the light radiations.

Solid Angle

Consider an area A which is part of a sphere of radius r (Fig. 3.1). Let us find the solid angle ω subtended by this area at the centre C of the sphere. For this purpose, let point C be joined to every point on the edges of the area A . Then, the angle enclosed by the cone at point C gives the solid angle. Its value is

$$\omega = \frac{A}{r^2} \text{ steradian}$$

The unit of solid angle is **steradian** (sr). If, in the above equation, $A = r^2$, then $\omega = 1$ steradian. Hence, steradian is defined as the angle subtended at the centre of a sphere by a part of its surface having an area equal to (radius)².

Obviously, the solid angle subtended at the centre by whole of the spherical surface = $4\pi \frac{r^2}{r^2} = 4\pi$ steradian (sr).

Definitions

Before proceeding further, definitions of a few principal terms employed in connection with illumination, are given below :

1. Candela. It is the unit of luminous intensity of a source. It is defined as 1/60th of the luminous intensity per cm² of a black body radiator at the temperature of solidification of platinum (2045°K). A source of one candela (cd) emits one lumen per steradian. Hence, total flux emitted by it allround is

$$4\pi \times 1 = 4 \text{ lumen}$$

2. Luminous Flux (F or Φ). It is the light energy radiated out per second from the body in the form of luminous light waves. Since, it is a rate of flow of energy, it is a sort of *power* unit. Unit of

luminous flux is *lumen* (ϕ lm). It is defined as the *flux contained per unit solid angle of a source of one candela or standard candle*

(Fig. 3.2). Approximate relation between lumen and electric unit of power *i.e.* watt is given as

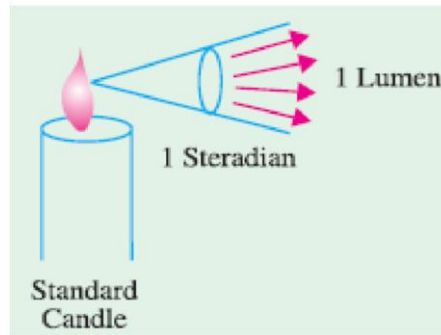

Fig 3.2

3. Lumen-hour. It is the quantity of light delivered in one hour by a flux of one lumen.*

4. Luminous Intensity (I) or Candle-power of a point source in any particular direction is given by the *luminous flux radiated out per unit solid angle in that direction*. In other words, it is solid angular flux density of a source in a specified direction. If $d\phi$ is the luminous flux radiated out by a source within a solid angle of $d\omega$ steradian in any particular direction, then $I = d\phi/d\omega$.

If flux is measured in lumens and solid angle in steradian, then its unit is lumen/steradian (lm/sr) or candela (*cd*).

If a source has an average luminous intensity of I lm/sr (or I candela), then total flux radiated by it all around is $\phi = \omega I = 4\pi I$ lumen.

Generally, the luminous intensity or candle power of a source is different in different directions.

The average candle-power of a source is the average value of its candle power in all directions.

Obviously, it is given by total flux (in lm) emitted in all directions in all planes divided by 4π .

This average candle-power is also known as *mean spherical candle-power* (M.S.C.P.).

$$\text{M.S.C.P.} = \frac{\text{total flux in lumens}}{4\pi}$$

If the average is taken over a hemisphere (instead of sphere), then this average candle power is known as *mean hemispherical candle-power* (M.H.S.C.P.).

It is given by the total flux emitted in a hemisphere (usually the lower one) divided by the solid angle subtended at the point source by the hemisphere.

$$\text{M.H.S.C.P.} = \frac{\text{flux emitted in a hemisphere}}{2 \pi}$$

5. **Reduction Factor** of a source is given by the ratio, $f = \text{M.S.C.P.}/\text{M.H.C.P.}$ where M.H.C.P. is the mean horizontal candle power.

It is also referred to as spherical reduction factor.

6. **Illuminance or Illumination (E).** When the luminous flux falls on a surface, it is said to be illuminated. The illumination of a surface is measured by the normal luminous flux per unit area received by it.

If $d\phi$ is the luminous flux incident normally on an area dA , then $E = d\phi/dA$ or $E = \phi/A$.

Luminance (L) of an Extended Source. Suppose ΔA is an element of area of an *extended* source and ΔI its luminous intensity when viewed in a direction making an angle ϕ with the perpendicular to the surface of the source (Fig. 49.3), then luminance of the source element is given by

$$L = \frac{\Delta I}{\Delta A \cos \phi} = \frac{\Delta I}{\Delta A'} \text{ cd/m}^2 \dots(i)$$

where $\Delta A' = \Delta A \cos \phi$

= area of the source element projected onto a plane perpendicular to the specified direction.

As will be seen from Art. 49.5.

$$E = \frac{I \cos \theta}{d^2} \quad \text{or} \quad \Delta E = \frac{\Delta I}{d^2} \cos \theta$$

Substituting the value of ΔI from Eq. (i) above, we get

$$\Delta E = \frac{L \cdot \Delta A'}{d^2} \cos \theta = L \cos \theta \cdot d\omega$$

where $d\omega = \Delta A'/d^2$ steradian

$$E = \int L \cos \theta \cdot d\omega = L \int \cos \theta \cdot d\omega$$

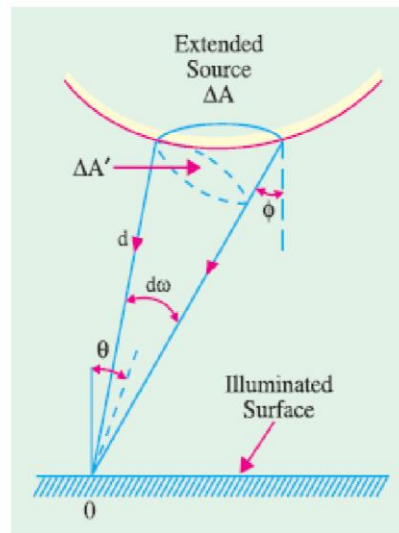

Fig. 49.3

—if L is constant.

8. **Luminous Exitance (M) of a Surface.** The luminous exitance (M) at a point on a surface is defined as luminous flux emitted per unit area in all directions. If an element of an illuminated area ΔA emits a total flux of $\Delta \Phi$ in all directions (over a solid angle of 2π steradian)

$$M = \Delta \Phi / \Delta A \quad \text{lm/m}^2$$

□

It can be proved that $M = L$ in the case of a uniform diffuse source.

Transmittance (T) of an Illuminated Diffuse Reflecting Surface. It is defined as the ratio of the total luminous flux transmitted by it to the total flux incident on it.

The relation between luminous exitance (M) of a surface transmitting light and illuminance (E) on the other side of it is

$$M = TE \quad \text{or} \quad T = M/E$$

Since light falling on a surface is either transmitted, reflected or absorbed the following relation holds good

$$T + \rho + \alpha = 1 \quad \text{where } \alpha \text{ is the absorptance of the surface.}$$

Reflection Ratio or Coefficient of Reflection or Reflectance (ρ). It is given by the luminous flux reflected from a small area of the surface to the total flux incident upon it $\rho = M/E$ i.e. ratio of luminous exitance and illuminance.

It is always less than unity. Its value is zero for ideal 'black body' and unity for a perfect reflector.

11. Specific Output or Efficiency of a lamp is the ratio of luminous flux to the power intake. Its unit is lumen/watt (lm/W). Following relations should be taken note of :

$$\begin{aligned} (a) \quad & \frac{\text{lumen}}{\text{watt}} = \frac{4\pi \times \text{M.S.C.P.}}{\text{watt}} \\ \text{or} \quad & \frac{\text{lm}}{\text{W}} = \frac{4\pi}{\text{watt/M.S.C.P.}} \\ (b) \quad & \text{since} \quad f = \text{M.S.C.P./M.H.C.P.} \quad \therefore \quad \text{lm/W} = \frac{4\pi f}{\text{watt/M.S.C.P.}} \\ (c) \quad & \text{Obviously, } \text{watts/M.S.C.P.} = \frac{4\pi}{\text{lm/W}} = \frac{\text{watt/M.H.C.P.}}{f} \\ (d) \quad & \text{Also} \quad \text{watts/M.H.C.P.} = \frac{4\pi f}{\text{lm/W}} = f \times \text{watts/M.S.C.P.} \end{aligned}$$

12. Specific Consumption. It is defined as the ratio of the power input to the average candlepower.

It is expressed in terms of watts per average candle or watts/M.S.C.P.

The summary of the above quantities along with their units and symbol is given in Table 49.1.

Table 49.1

Name of Qty	Unit	Symbols
Luminous Flux	Lumen	F or Φ
Luminous Intensity (candle-power)	Candela	I
Illumination or Illuminance	lm/m^2 or lux	E
Luminance or Brightness	cd/m^2	L or B
Luminous Exitance	lm/m^2	M

Calculation of Luminance (L) of a Diffuse Reflecting Surface

The luminance (or brightness) of a surface largely depends on the character of the surface, if it is itself not the emitter. In the case of a polished surface, the luminance depends on the angle of viewing. But if the surface is matt and diffusion is good, then the luminance or brightness is practically independent of the angle of viewing. However, the reflectance of the surface reduces the brightness proportionately. In Fig. 3.4 is shown a perfectly diffusing surface of small area A . Suppose that at point M on a hemisphere with centre O and radius R , the illuminance is $L \text{ cd/m}^2$.

Obviously, **luminous intensity** at point M is $= L \cdot A \cos \theta$ candela (or lumen/steradian). Now, the hemisphere can be divided into a number of zones as shown.

Consider one such zone MN between θ and $(\theta + d\theta)$. The width of this zone is $R \cdot d\theta$ and length $2R \sin \theta$ so that its area (shown shaded) is $= 2R^2 \sin \theta \cdot d\theta$. Hence, it subtends a solid angle $= 2R^2 \sin \theta \cdot d\theta / R^2 = 2 \sin \theta \cdot d\theta$ steradian at point O . The luminous flux passing through this zone is $d\phi = L A \cos \theta \cdot 2 \sin \theta \cdot d\theta = L A \sin 2\theta \cdot d\theta$ lumen
 Total flux passing through the whole hemisphere is

$$\Phi = \int_0^{\pi/2} \pi L A \sin 2\theta \cdot d\theta = \pi L A \text{ lumen}$$

coefficient, then $\phi = \rho A E$ lumen.

Equating the two values of flux, we have $\pi L A = \rho A E$ or $L = \rho E / \pi \text{ cd/m}^2 = E \text{ lm/m}^2$ For example, consider a perfectly diffusing surface having $\rho = 0.8$ and held at a distance of 2 metres from a source of luminous intensity 100 candela at right angles to the direction of flux. Then

$$E = \frac{I}{r^2} = \frac{100}{2^2} = 25 \text{ lm/m}^2$$

$$L = \frac{\rho}{\pi} \cdot 25 = \frac{0.8}{\pi} \cdot 25 = 6.36 \text{ cd/m}^2 = 636 \text{ lm/m}^2$$

Laws of Illumination or Illuminance

The illumination (E) of a surface depends upon the following factors. The source is assumed to be a point source or is otherwise sufficiently away from the surface to be regarded as such. (i) E is directly proportional to the luminous intensity (I) of the source or $E \propto I$

(ii) **Inverse Square Law.** The illumination of a surface is inversely proportional to the square of the distance of the surface from the source. In other words, $E \propto 1/r^2$

Proof In Fig. 49.5 are shown portions of the surfaces of three spheres whose radii are in the ratio 1 : 2 : 3. All these portions, obviously, subtend the same solid angle at the source and hence receive the same amount of total flux. However, since their areas are in the ratio of 1 : 4 : 9, their illuminations are in the ratio 1 : 1/4 : 1/9

(iii) **Lambert’s Cosine Law.** According to this law, E is directly proportional to the cosine of the angle made by the normal to the illuminated surface with the direction of the incident flux.

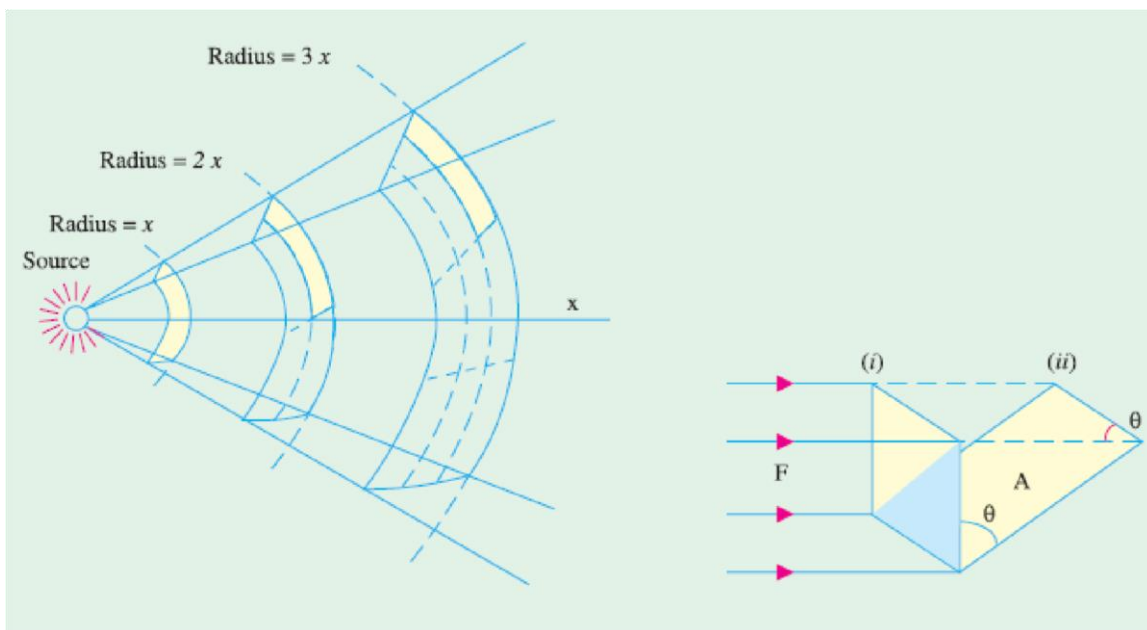

Fig 3.5

Proof

As shown in Fig. 3.6, let ϕ be the flux incident on the surface of area A when in position 1. When this surface is turned back through an angle θ , then the flux incident on it is $\phi \cos \theta$. Hence, illumination of the surface when in position 1 is $E_1 = \phi/A$. But when in position 2,

$$E_2 = \frac{\Phi \cos \theta}{A} \quad \therefore \quad E_2 = E_1 \cos \theta$$

Combining all these factors together, we get $E = I \cos \theta / r^2$. The unit is lm/m².

ϕ

The above expression makes the determination of illumination possible at a given point provided the position and the luminous intensity or candle power (in the given direction) of the source (or sources) by which it is illuminated are known as illustrated by the following examples.

Consider a lamp of uniform luminous intensity suspended at a height h above the working plane as shown in Fig. 49.7. Let us consider the value of illumination at point A immediately below the lamp and at other points B, C, D etc., lying in the working plane at different distances from A .

$$E_A = \frac{I}{h^2} \text{ — since } \theta = 0 \text{ and } \cos \theta = 1$$

$$E_B = \frac{I}{LB^2} \times \cos \theta_1. \quad \text{Since, } \cos \theta_1 = h / LB$$

$$E_B = \frac{I}{LB^2} \times \frac{h}{LB} = I \times \frac{h}{LB^3} = \frac{1}{h^2} \cdot \frac{h^3}{LB^3} = \frac{1}{h^2} \left(\frac{h}{LB} \right)^3$$

$$\text{Now } \frac{1}{h^2} = E_A \text{ and } \left(\frac{h}{LB} \right)^3 = \cos^3 \theta_1$$

$$\therefore E_B = E_A \cos^3 \theta_1$$

$$\text{Similarly, } E_C = E_A \cdot \cos^3 \theta_2 \text{ and } E_D = E_A \cos^3 \theta_3 \text{ and so on.}$$

Laws Governing Illumination of Different Sources

The laws applicable to the illumination produced by the following three types of sources will be considered. (i) **Point Source**

As discussed in Art. 3.5, the law governing changes in illumination due to point source of light is $E = I \cos \Theta / d^2$.

(ii) **Line Source**

Provided the line source is of infinite length and of uniform intensity, the illumination at a point lying on a surface parallel to and facing the line source is given by

$$E = I / 2d \text{ lm/m}^2$$

where I = luminous intensity normal to the line source (in candles per-meter length of the sources)

$$E = \frac{\pi I}{2 d} \text{ lm/m}^2$$

where I = luminous intensity normal to the line source (in candles per-meter length of the sources)

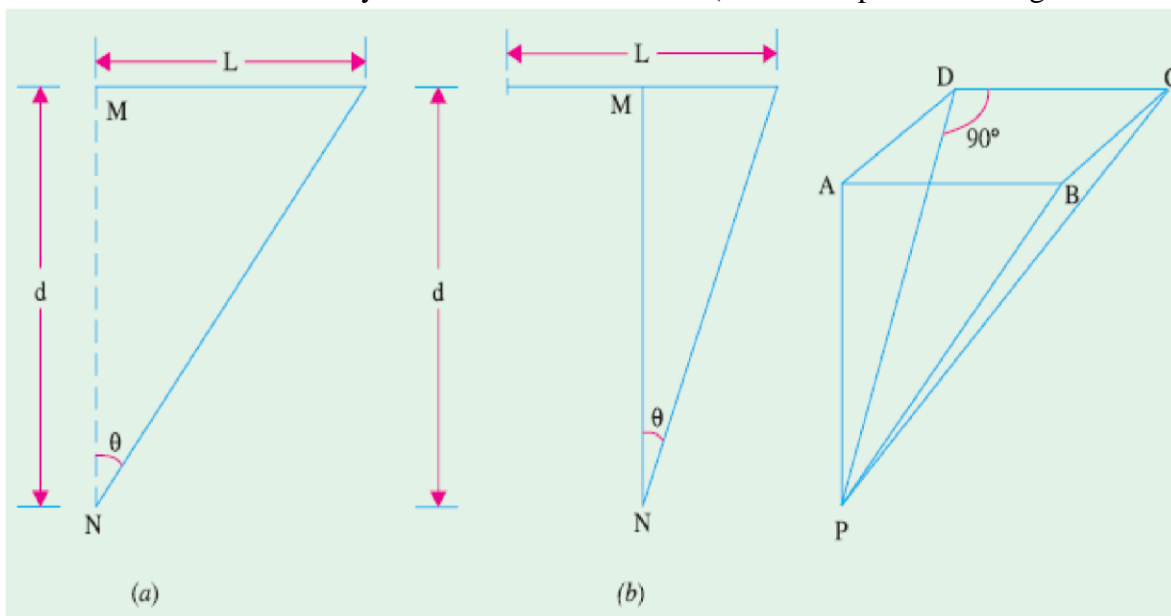

Fig. 49.18

Fig. 49.19

However, in practice, the line sources are of finite length, so that the following law applies

$$E = \frac{I}{4 d} (\sin 2\theta + 2\theta) \text{ lm/m}^2 \dots\dots\dots 49.8(a)$$

$$= \frac{I}{2 d} (\sin 2\theta + 2\theta) \text{ lm/m}^2 \dots\dots\dots 49.8(b)$$

where I = candle power per metre length in a direction normal to the line source

$$= \frac{\Phi}{\pi^2 L} \text{ cd/m}$$

where Φ is the total flux of the source in lumens and L is the length of the line source in metres

Polar Curves of C.P. Distribution

All our calculations so far were based on the tacit assumption that the light source was of equal luminous intensity or candle-power in all directions. However, lamps and other sources of light, as a rule, do not give uniform distribution in the space surrounding them. If the actual luminous intensity of a source in various directions be plotted to scale along lines radiating from the centre of the source at corresponding angles, we obtain the polar curve of the candle power. Suppose we construct a figure consisting of large number of spokes radiating out from a point—the length of each spoke representing to some scale the candle power or luminous intensity of the source in that particular direction. If now we join the

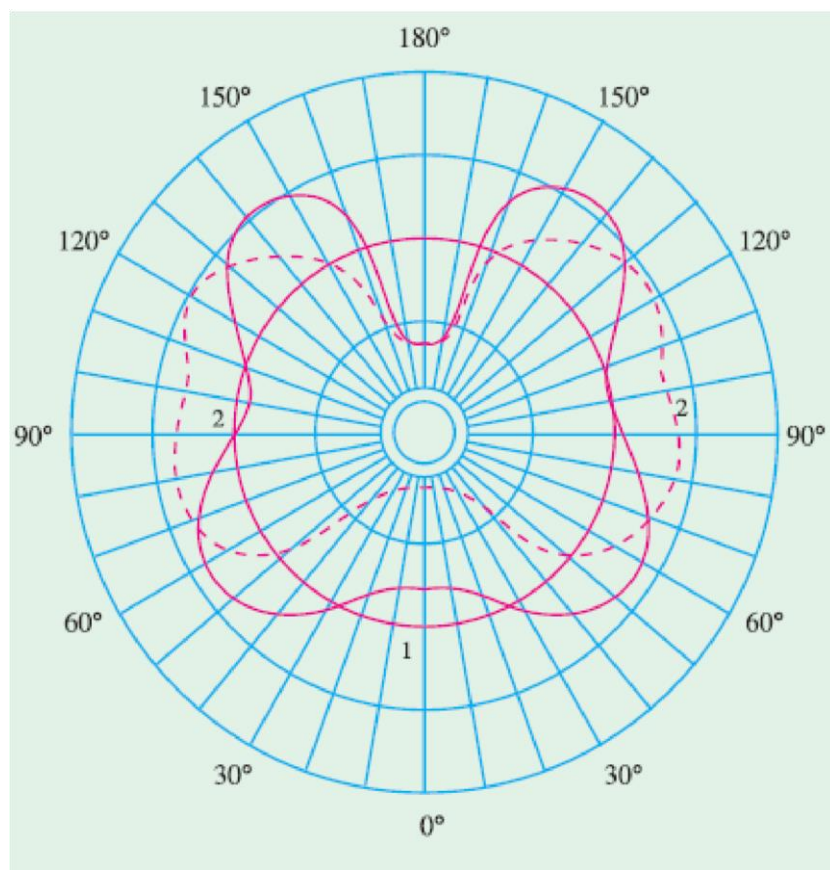

Fig. 49.20

ends of these spokes by some suitable material, say, by linen cloth, then we get a surface whose shape will represent to scale the three dimensional candle power distribution of the source placed at the centre. In the ideal case of a point source having equal distribution in all directions, the surface would be spherical. It would be realized that it is difficult to give a

graphic representation of such a 3-dimensional model in a plane surface. Therefore, as with engineering drawings, it is usual to draw only one or more elevations and a plan of sections through the centre of the source. Elevations represent c.p. distribution in the **vertical** plane and the plans represent c.p. distribution in **horizontal** plane. The number of elevations required to give a complete idea of the c.p. distribution of the source in all directions depends upon the shape of the plan *i.e.* on the horizontal distribution. If the distribution is uniform in every horizontal plane *i.e.* if the polar curve of horizontal distribution is a circle, then only one vertical curve is sufficient to give full idea of the space distribution. In Fig.

3.20 are shown two polar curves of c.p. distribution in a vertical plane. Curve 1 is for

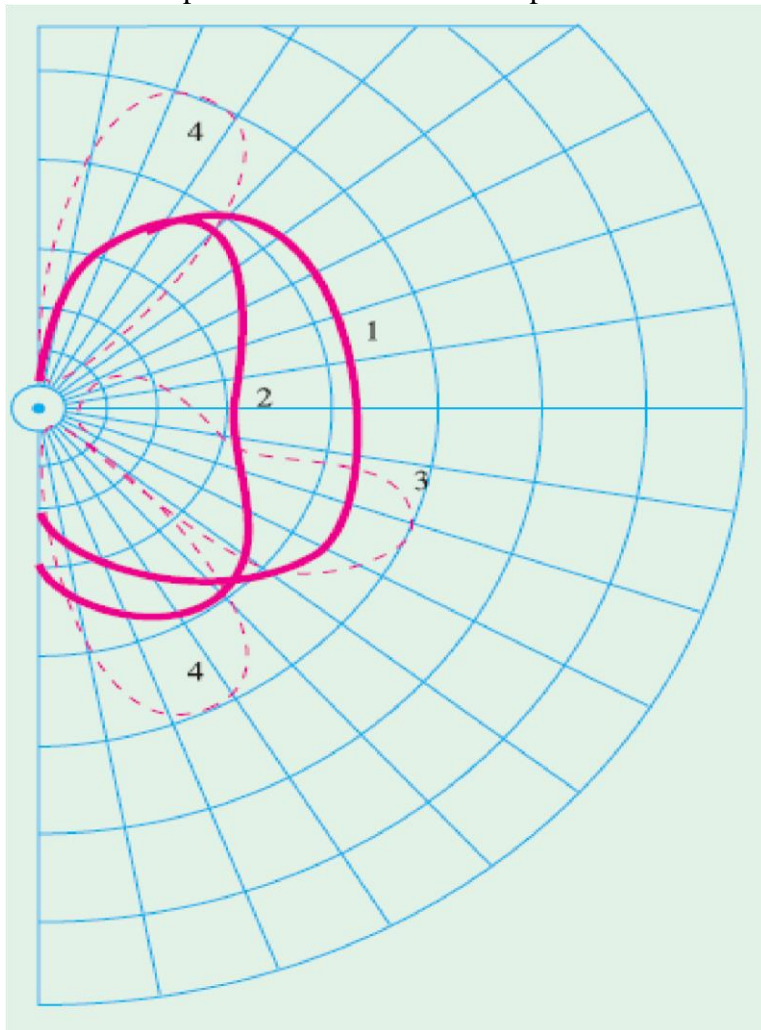

Fig 3.21

vacuum type tungsten lamp with zig-zag filament whereas curve 2 is for gas filled tungsten lamp with filament arranged as a horizontal ring.

If the polar curve is symmetrical about the vertical axis as in the figures given below, then it is sufficient to give only the polar curve within one semicircle in order to completely define the

distribution of c.p. as shown in Fig. 3.21. The curves 1 and 2 are as in Fig. 3.20, curves 3 is for d.c. open arc with plain carbons and curve 4 is for a.c. arc with plain carbons. However, if the source and/or reflector are not symmetrical about vertical axis, it is impossible to represent the space distribution of c.p. by a single polar diagram and even polar diagrams for two planes at right angles to each other give no definite idea as to the distribution in the intermediate planes.

Consider a filament lamp with a helmet-type reflector whose axis is inclined and cross-section elliptical—such reflectors are widely used for lighting shop windows. Fig. 3.22 represents the distribution of luminous intensity of such source and its reflector in two planes at right angles to each other. The importance of considering the polar curves in different planes when the c.p. distribution in asymmetrical is even more strikingly depicted by the polar curves in *YY* plane and *XX* plane of a lamp with a special type of reflector designed for street lighting purposes (Fig. 3.23).

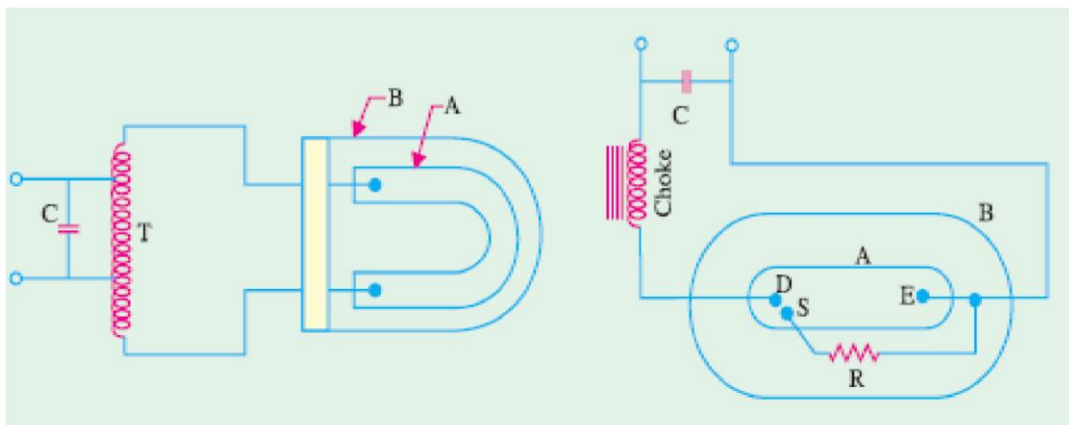

Fig 3.22

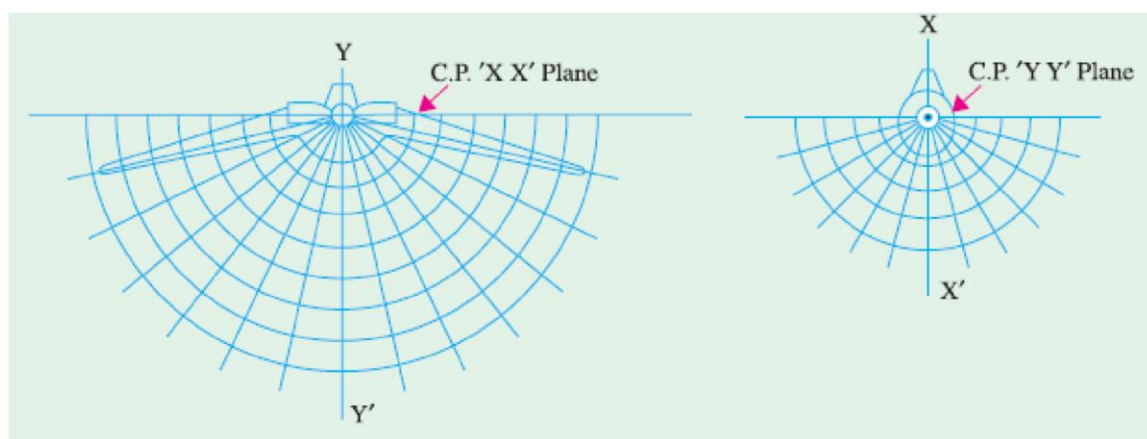

Fig 3.33

It would be realized from above that the polar distribution of light from any source can be given any desired form by using reflectors and/or refractors of appropriate shape.

In Fig. 3.24 is shown the polar curve of c.p. distribution of a straight type of lamp in a horizontal plane.

Uses of Polar Curves

Polar curves are made use of in determining the M.S.C.P. etc. of a source. They are also used in determining the actual illumination of a surface *i.e.* while calculating the illumination in a particular direction, the c.p. in that particular direction as read from the vertical polar curve, should be employed.

Determination of M.S.C.P. and M.H.C.P. from Polar Diagrams

In Fig. 3.25 (a) is shown the polar distribution curve of a filament lamp in a horizontal plane and the polar curve in

Fig. 3.25 (b) represents the c.p. distribution in a vertical plane. It will be seen that the horizontal candle-power is almost uniform in all directions in that plane. However, in the vertical plane, there is a large variation in the candle power which falls to zero behind the cap of the lamp. The curve in Fig. 3.25 (a)

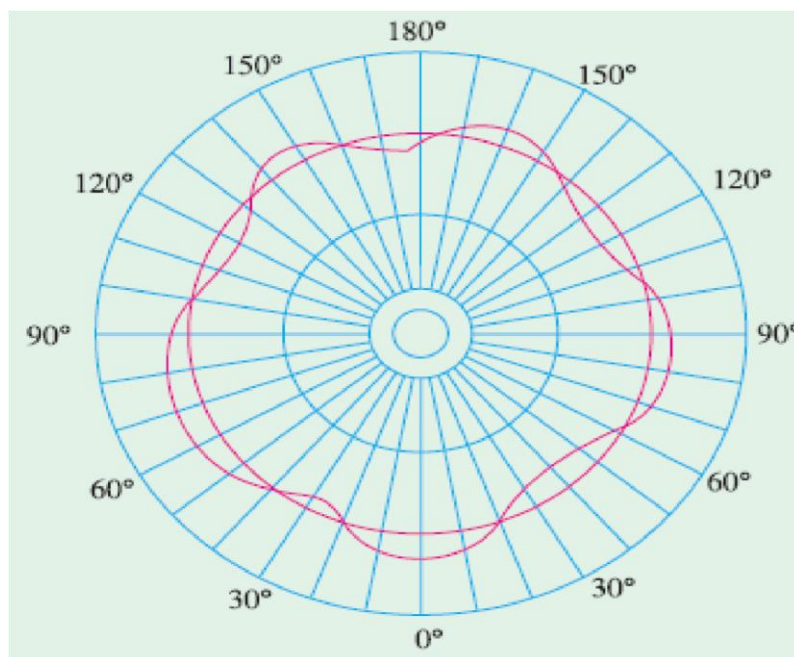

Fig 3.24

has been drawn with the help of a photometer while the lamp is rotated about a vertical axis, say, 10° at a time. But the curve in Fig. 49.25 (b) was drawn while the lamp was rotated in a vertical plane about a horizontal axis passing through the centre of the filament. The M.H.C.P. is taken as the mean of the readings in Fig. 49.25 (a). However, a more accurate result can be

obtained by plotting candle power on an angular base along the rectangular axes and by determining the mean height of the curve by the mid-ordinate or by Simpson’s rule. The M.S.C.P. of the lamp can be obtained from the vertical polar curve of Fig. 3.25 (b) by

Rousseau’s construction as explained below :

Only half of the vertical polar curve is shown in the figure (Fig. 49.26) since it is symmetrical about the vertical axis. With O is the centre and radius OR equal to the maximum radius of the polar curve, a semi-circle LRM is drawn. A convenient number of points on this semi-circle (say 10° points) are projected onto any vertical plane as shown. For example, points a, b, c etc. are projected to d, e, f and so on. From point d , the horizontal line dg is drawn equal to the intercept OA of the polar diagram on the radius oa . Similarly, $eh = OB$, $fk = OC$ and so on. The points g, h, k etc., define the

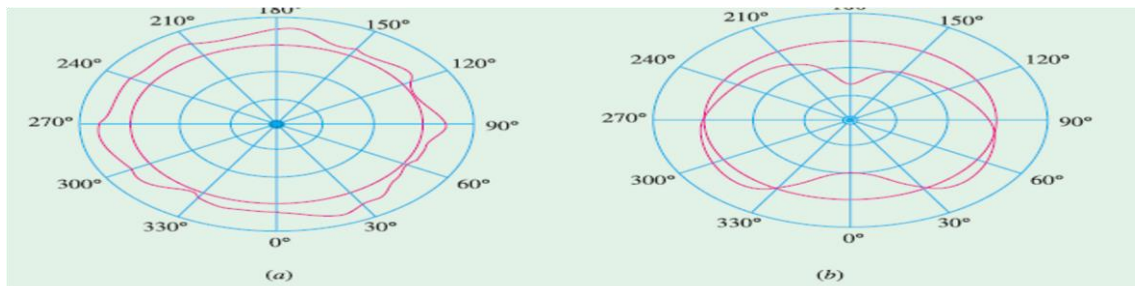
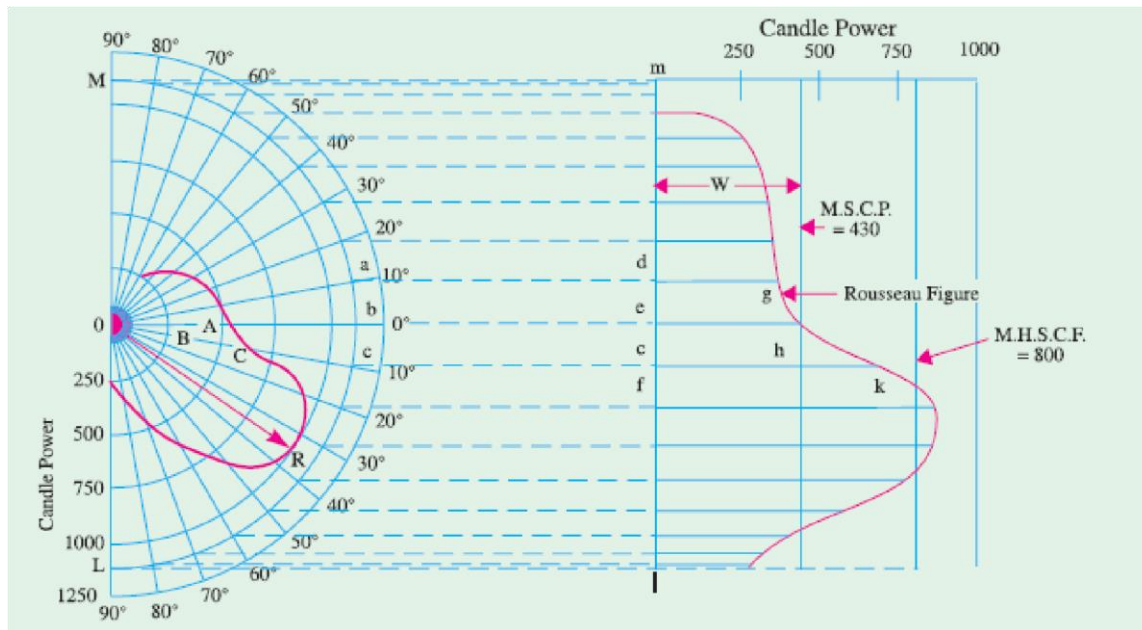

Fig 3.25

Rousseau figure. The average width w of this figure represents the M.S.C.P. to the same scale as that of the candle powers in the polar curve. The average width is obtained by dividing the Rousseau area by the base of the Rousseau figure *i.e.* length lm which is the projection of the semi-circle LM on the

vertical axis. The area may be determined by Simpson’s rule or by using a planimeter



∴
$$\text{M.S.C.P.} = \frac{\text{area of Rousseau figure}}{\text{length of the base}}$$

As explained earlier, the M.H.C.P. of an incandescent lamp can be easily obtained by mounting the lamp with its axis vertical and taking photometer readings in the horizontal plane while the lamp is rotated about its axis in steps of 10° or so. A definite ratio exists between the M.H.C.P. and M.S.C.P. of each particular type of filament. M.S.C.P. of a lamp can be found by multiplying M.H.C.P. by a factor known as spherical reduction factor which, as defined earlier, is

Spherical reduction factor $f = \frac{\text{M.S.C.P.}}{\text{M.H.C.P.}}$ ∴ $\text{M.S.C.P.} = f \times \text{M.H.C.P.}$

For the particular lamp considered, $f = 430/80 = 0.54$ (approx.)
 Typical values of this factor are : Ordinary vacuum-type tungsten lamp having zig-zag filament 0.76 – 0.78
 Gas-filled tungsten lamp with filament in the form of broad shallow V's 0.85 – 0.94
 Gas-filled tungsten lamp with filament in the shape of a horizontal ring 1.0 – 1.2

The total lumen output is given by the relation ; lumen output = 4π × M.S.C.P. In the present case,
 lumen output = 4π × 430
 = 5,405 lm

Integrating Sphere or Photometer

The M.S.C.P. is usually measured by means of an integrating photometer, the most accurate form of which consists of a hollow sphere (as originally proposed by Ulbricht) whose diameter is large (at least 6 times) as compared to that of the lamp under test. The interior surface of the hollow sphere is whitened by means of a special matt white paint. When the lamp is placed inside the sphere (not

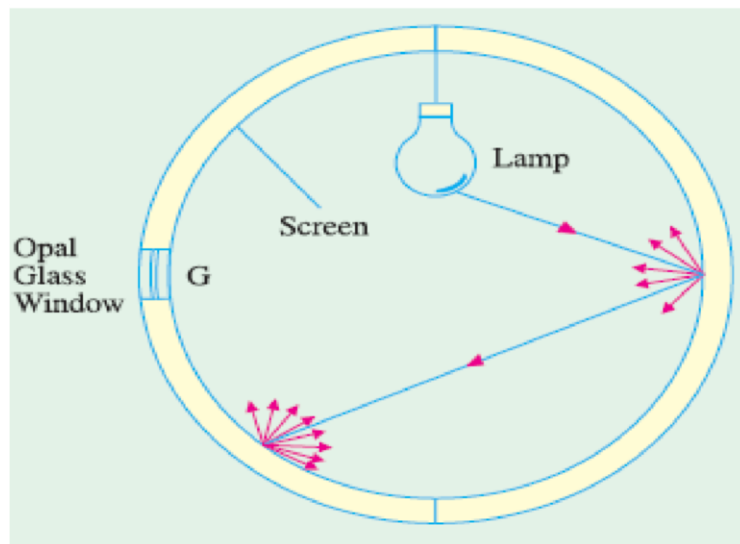

Fig 3.27

necessarily at its centre) then due to successive reflections, its light is so diffused as to produce a uniform illumination over the whole surface. At some point, a small matt opal-glass window, shaded from the direct rays of the source, is made in the hollow sphere. The brightness of the matt opal glass is proportional to that of the interior surface of the sphere.

By using a suitable illumination photometer, the illumination of the window can be measured which can be used to find out the total flux emitted by the source.

Total flux = illumination (lm/m^2) \times surface area of the sphere (m^2) \therefore M.S.C.P. = total flux/4 candela

Theory. In Fig. 3.28 is shown a light source L of luminous intensity I candela and having a total flux output of FL placed at the centre of an integrating sphere of radius r and reflection factor ρ . Let EA and EB represent the illuminations at two points A and B , each of infinitely small area da and db respectively and distance m apart. We will now consider total illumination (both direct and reflected) at point A . Obviously EA directly due to $L = I/r^2$ EB directly due to $L = I/r^2$

Luminous intensity of B in the direction of A is

$$I_B = \frac{\rho \cdot E_B \cdot A_B}{\pi} \text{ candela} \quad \text{---Art. 45.4}$$

where $A_B =$ projected area of B at right angles to the line $BA = db \cdot \cos \theta$

$$\therefore I_B = \frac{\rho \cdot I \cdot db \cos \theta}{\pi r^2} \text{ candela}$$

Hence, illumination of A due to B is $= \frac{I_B \cos \theta}{m^2} = \frac{\rho I \cdot db \cos^2 \theta}{\pi r^2 \times m^2}$

Now, as seen from Fig. 49.28, $m = 2r \cos \theta$

\therefore illumination of A due to B becomes

$$= \frac{\rho \cdot I \cdot db \cos^2 \theta}{\pi r^2 \times 4r^2 \cos^2 \theta} = \frac{\rho}{4\pi r^2} \times \frac{I}{r^2} \times db = \frac{\rho}{S} \cdot E_B \cdot db = \frac{\rho F_B}{D}$$

where $F_B =$ flux incident on B and $A =$ surface area of the sphere

Hence, total illumination due to first reflection $= \sum \frac{\rho F_B}{S} = \frac{\rho F_B}{S}$

Now, consider any other point C . Illumination on B due to point $C = \rho F_L/S$. The illumination on A due to C as reflected from B .

$$= \left[\rho \cdot \left(\frac{\rho F_L}{S} \right) \times \frac{db \cos \theta}{\pi} \right] \times \frac{\cos \theta}{m^2} = \frac{\rho F_L}{S} \times \frac{\rho \cdot db \cos \theta}{\pi} \times \frac{\cos \theta}{4r^2 \cos^2 \theta}$$

$$= \frac{\rho F_L}{S} \times \frac{\rho \cdot db}{S}$$

Total illumination due to two reflections $= \sum \frac{\rho F_L}{S} \times \frac{\rho \cdot db}{S} = \frac{\rho^2 F_L}{S} \quad (\because \sum ab = S)$

Continuing this way, it can be proved that total illumination at point A from all reflections from all points

$$= \frac{\rho F_L}{S} (1 + \rho^2 + \rho^3 + \dots + \rho^{n-1}) = \frac{\rho F_L}{S} \left(\frac{1}{1-\rho} \right)$$

Hence, total illumination at A from direct and reflected lights is

$$= E_A + \frac{\rho F_L}{S} \left(\frac{1}{1-\rho} \right)$$

If A is shielded from lamp L , then its illumination is proportional to FL because $\frac{\rho}{S} \left(\frac{1}{1-\rho} \right)$ is a constant factor. Obviously, if either brightness or illumination at one point in the sphere is measured, it would be proportional to the light output of the source. This fact is made use of while using this sphere as a globe photometer.

Floodlighting

It means ‘flooding’ of large surfaces with the help of light from powerful projectors. Flooding is employed for the following purposes :

1. For aesthetic purposes as for enhancing the beauty of a building by night *i.e.* flood lighting of ancient monuments, religious buildings on important festive occasions etc.

2. For advertising purposes *i.e.* flood lighting, huge hoardings and commercial buildings.
3. For industrial and commercial purposes as in the case of railway yards, sports stadiums and quarries etc.

Usually, floodlight projectors having suitable reflectors fitted with standard 250-, 500, or 1,000-watt gas-filled tungsten lamps, are employed. One of the two typical floodlight installations often used is as shown in

Fig. 3.44(a). The projector is kept 15 m to 30 m away from the surface to be floodlighted and provides approximately parallel beam having beam spread of 25° to 30° . Fig. 3.44(b) shows the case when the projector cannot be located away from the building. In that case, an asymmetric reflector is used which directs more intense light towards the top of the building. The total luminous flux required to floodlight a building can be found from the relation, $\Phi = \frac{EA}{\eta p}$.

However, in the case of flood-lighting, one more factor has to be taken into account. That factor is known as waste-light factor (W). It is so because when several projectors are used, there is bound to be a certain amount of overlap and also because some light would fall beyond the edges of the area to be illuminated. These two factors are taken into account by multiplying the theoretical value of the flux required by a waste-light factor which has a value of nearly 1.2 for regular surfaces and about

1.5 for irregular objects like statues etc. Hence, the formula for calculation of total flux required for floodlighting purposes is

$$\Phi = \frac{EAW}{\eta p}$$

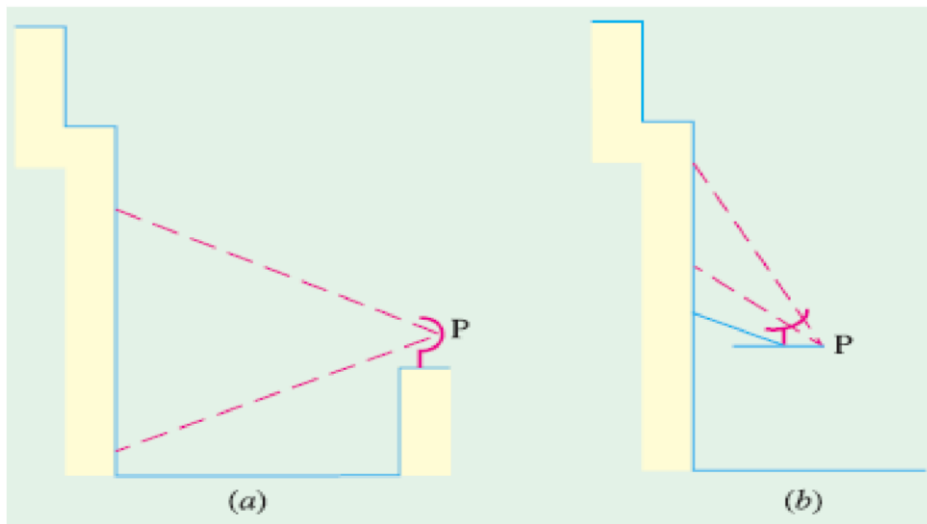

Fig 3.44

Artificial Sources of Light

The different methods of producing light by electricity may, in a broad sense, be divided into three groups.

1. By *temperature incandescence*. In this method, an electric current is passed through a filament of thin wire placed in vacuum or an inert gas. The current generates enough heat to raise the temperature of the filament to luminosity.

Incandescent tungsten filament lamps are examples of this type and since their output depends on the temperature of their filaments, they are known as *temperature radiators*.

2. By establishing an arc between two carbon electrodes. The source of light, in their case, is the incandescent electrode.

3. *Discharge Lamps*. In these lamps, gas or vapour is made luminous by an electric discharge through them. The colour and intensity of light *i.e.* candle-power emitted depends on the nature of the gas or vapour only. It should be particularly noted that these discharge lamps are luminiscentlight lamps and do not depend on temperature for higher efficiencies. In this respect, they differ radically from incandescent lamps whose efficiency is dependent on temperature. Mercury vapour lamp, sodium-vapour lamp, neon-gas lamp and fluorescent lamps are examples of light sources based on discharge through gases and vapours.

Incandescent Lamp

An incandescent lamp essentially consists of a fine wire of a high-resistance metal placed in an evacuated glass bulb and heated to luminosity by the passage of current through it. Such lamps were

* It indicates the divergence of a beam and may be defined as the angle within which the minimum illumination on a surface normal to the axis of the beam is 1/10th of the maximum. produced commercially for the first time by Edison in 1879.

His early lamps had filaments of carbonized paper which were, later on, replaced by carbonized bamboo. They had the disadvantage of negative temperature coefficient of resistivity. In 1905, the metallized carbon-filament lamps were put in the market whose filaments had a positive temperature coefficient of resistivity (like metals). Such lamps gave 4 lm/W. At approximately the same time, osmium lamps were manufactured which had filaments made of osmium which is very rare and expensive metal. Such lamps had a very fair maintenance of candle-power during their useful life and an average efficiency of 5 lm/W. However, osmium filaments were found to be very fragile.

In 1906 tantalum lamps having filaments of tantalum were produced which had an initial efficiency of 5 lm/watt. All these lamps were superseded by tungsten lamps which were commercially produced in about 1937 or so. The superiority of tungsten lies mainly in its ability to withstand a high operating temperature without undue vaporisation of the filament. The necessity of high working temperature is due to the fact that the amount of visible radiation increases with temperature and so does the radiant efficiency of the luminous source. The melting temperature of tungsten is 3655°K whereas that of osmium is 2972°K and that of tantalum is 3172°K. Actually, carbon has a higher melting point than tungsten but its operating temperature is limited to about 2073°K because of rapid vaporization beyond this temperature.

In fact, the ideal material for the filament of incandescent lamps is one which has the following properties :

1. A high melting and hence operating temperature
2. A low vapour pressure
3. A high specific resistance and a low temperature coefficient
4. Ductility and
5. Sufficient mechanical strength to withstand vibrations. Since tungsten possesses practically all the above mentioned qualities, it is used in almost all modern incandescent lamps. The earlier lamps had a square-cage type filament supported from a central glass stem enclosed in an evacuated glass bulb.

The object of vacuum was two fold : (a) to prevent oxidation and

(b) to minimize loss of heat by convection and the consequent lowering of filament temperature. However, vacuum favoured the evaporation of the filament with the resulting blackening of the lamp so that the operating temperature had to be kept as low as 2670° K with serious loss in luminous efficiency

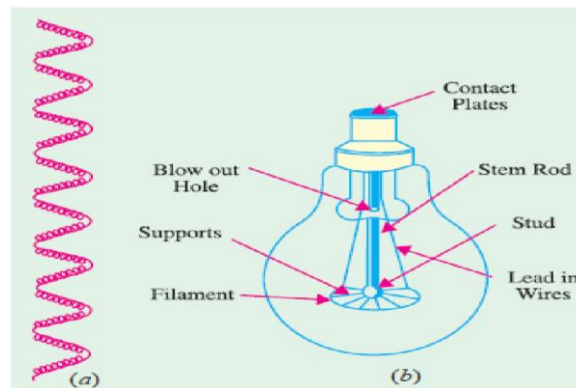

Fig 3.46

It was, later on, found that this difficulty could be solved to a great extent by inserting a chemically inert gas like nitrogen or argon. The presence of these gases within the glass bulb decreased the evaporation of the filament and so lengthened its life. The filament could now be run at a relatively higher temperature and hence higher luminous efficiency could be realized. In practice, it was found that an admixture of 85% argon and about 15 percent nitrogen gave the best results. However, introduction of gas led to another difficulty *i.e.* loss of heat due to convection which offsets the additional increase in efficiency. However, it was found that for securing greater efficiency, a concentrated filament having a tightly-wound helical construction was necessary. Such a coiled filament was less exposed to circulating gases, its turns supplying heat to each other and further the filament was mechanically stronger. The latest improvement is that the coiled filament is itself

‘coiled’ resulting in ‘coiled-coil’ filament Fig. 3.46 (a) which leads to further concentrating the heat, reducing the effective exposure to gases and allows higher temperature operation, thus giving greater efficiency. The construction of a modern coiledcoil gas-filled filament lamp is shown in Fig. 49.46

(b). The lamp has a ‘wreath’ filament *i.e.* a coiled filament arranged in the form of a wreath on radial supports

Filament Dimensions

There is found to be a definite relation between the diameter of a given filament and the current.

Consider a filament operating at a fixed temperature and efficiency.

Then since no heat is being utilized for further raising the temperature, all the heat produced in a given time is mostly lost by radiation (if vacuum is good). In other words, Heat produced per second = heat lost per second by radiation

$$\text{Now, power intake} = I^2 R = I^2 \times \frac{\rho l}{A} = \frac{I^2 \rho l}{\pi d^2 / 4} = I^2 \left(\frac{4\rho l}{\pi d^2} \right)$$

where, I = filament current in amperes, l = filament length A = filament cross-section d = filament diameter ρ = resistivity of filament material at the working temperature.

Heat radiated per second from the surface is proportional to the area of the surface and emissivity of the material

$$\begin{aligned} \therefore \text{heat lost/second} &\propto \text{surface area} \times \text{emissivity } \sigma \\ \therefore I^2 \left(\frac{4\rho l}{\pi d^2} \right) &\propto l \times \pi d \times \sigma \quad \text{or} \quad I^2 \propto d^3 \quad \dots(i) \\ \therefore I &\propto d^{1.5} \quad \text{or} \quad d \propto I^{2/3} \end{aligned}$$

In general, for two filaments of the same material working at the same temperature and efficiency, the relation as seen from (i) above is

$$\left(\frac{I_1}{I_2} \right)^2 = \left(\frac{d_1}{d_2} \right)^3$$

It would be noticed that the above expressions are similar to those concerning fusing current of a given material under stated conditions (Preece's Rule).

Moreover, for two filaments working at the same temperature, the flux per unit area is the same. Denoting their lengths by l_1 and l_2 and their diameters by d_1 and d_2 respectively, we have, Lumen output $\propto l_1 d_1^2 \propto l_2 d_2^2$ or $l_1 d_1^2 = l_2 d_2^2 = \text{constant}$.

Incandescent Lamp Characteristics

The operating characteristics of an incandescent lamp are materially affected by departure from its normal working voltage. Initially, there is a rapid heating up of the lamp due to its low thermal capacity, but then soon its power intake becomes steady. If the filament resistance were not dependent on its temperature, the rate of generation of heat would have been directly proportional to the square of voltage applied across the lamp. However, because of *(i)* positive temperature coefficient of resistance and *(ii)* complex mechanism of heat transfer from filament to gas, the relations between the lamp characteristics and its voltage are mostly experimental. Some of the characteristics of gasfilled lamps are given below.

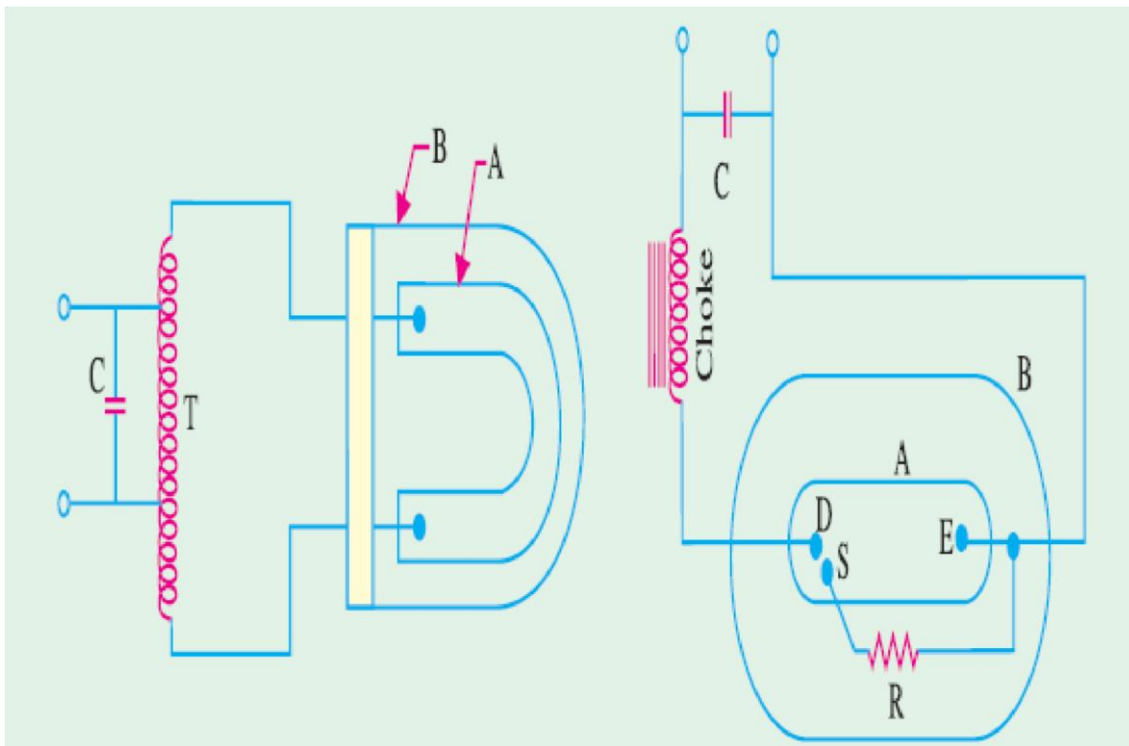

Fig 3.47

It is found that candle power or lumen output of the lamp varies with the voltage as lumen Output $\propto V^{3.3}$.

(ii) Variation of lumen output in terms of current is given by : lumen output $\propto I^5$

(iii) Life of the lamp is given by : life $\propto 1/V^{1.3}$

(iv) Wattage is given by $W \propto V^{1.43}$

(v) Its lumen/watt is given by : lm/watt $\propto V^2$

The characteristic curves are plotted in Fig. 49.47. The life characteristic is very revealing.

Even a small undervoltage considerably increases its life whereas overvoltage of as small a value as 5% shortens its life by 50%.

High-pressure Mercury Vapour Lamp

Like sodium-vapour lamp, this lamp is also classified as electric discharge lamp in which light is produced by gaseous conduction. Such a lamp usually consists of two bulbs — an arc-tube containing the electric discharge and an outer bulb which protects the arc-tube from changes in temperature. The

inner tube or arc tube A is made of quartz (or hard glass) the outer bulb B of hard glass. As shown in Fig. 3.49, the arc tube contains a small amount of mercury and argon gas and houses three electrodes D , E and S . The main electrodes are D and E whereas S is the auxiliary starting electrode. S is connected through a high resistance R (about $50\text{ k}\Omega$) to the main electrode situated at the outer end of the tube. The main electrodes consist of tungsten coils with electron-emitting coating or elements of thorium metal.

When the supply is switched on, initial discharge for the few seconds is established in the argon gas between D and S and then in the argon between D and E . The heat produced due to this discharge through the gas is sufficient to vaporise mercury. Consequently, pressure inside A increases to about one or two atmospheres and the p.d. across D and E grows from about 20 to 150 V, the operation taking about 5-7 minutes. During this time, discharge is established through the mercury vapours which emit greenish-blue light.

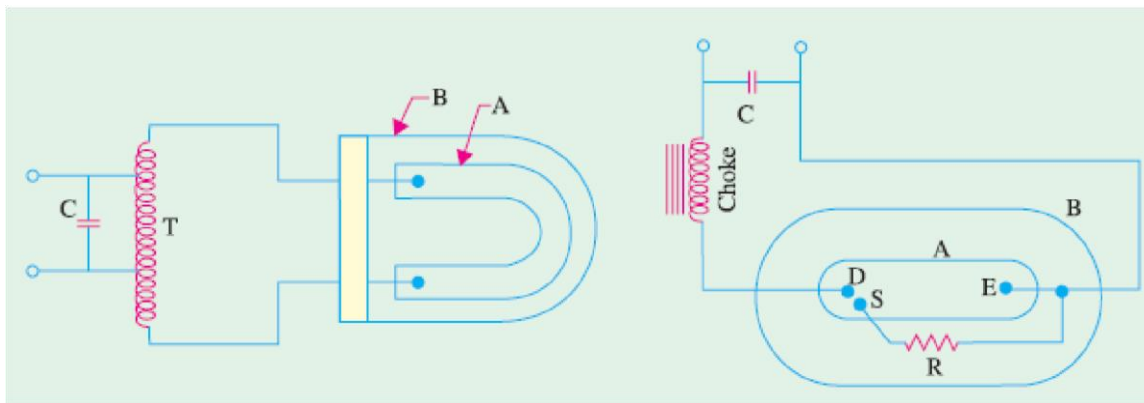

Fig 3.48

The choke serves to limit the current drawn by the discharge tube A to a safe limit and capacitor C helps to improve the power factor of the circuit.

True colour rendition is not possible with mercury vapour lamps since there is complete absence of red-light from their radiations. Consequently, red objects appear black, all blues appear mercury-spectrum blue and all greens the mercury-spectrum green with the result that colour values are distorted.

Correction for colour distortion can be achieved by

1. Using incandescent lamps (which are rich in red light) in combination with the mercury lamps.
2. Using colour-corrected mercury lamps which have an inside phosphor coat to add red colour to the mercury spectrum.

Stroboscopic (Flickering) effect in mercury vapour lamps is caused by the 100 on and off arc strikes when the lamps are used on the 50-Hz supply. The effect may be minimized by

1. Using two lamps on lead-lag transformer
2. Using three lamps on separated phases of a 3-phase supply
- and 3. Using incandescent lamps in combination with mercury lamps.

In the last few years, there has been tremendous improvement in the construction and operation of mercury-vapour lamps, which has increased their usefulness and boosted their application for all types of industrial lighting, floodlighting and street lighting etc. As compared to an incandescent lamp, a mercury-vapour lamp is (a) smaller in size (b) has 5 to 10 times longer operating life and (c) has 3 times higher efficiency *i.e.* 3 times more light output for given electrical wattage input.

Typical mercury-vapour lamp applications are :

1. High-bay industrial lighting — where high level illumination is required and colour rendition is not important.
2. Flood-lighting and street-lighting

Fluorescent Lamp Circuit with Thermal Switch

The circuit arrangement is shown in Fig. 3.52. The switch has a bimetallic strip close to a resistance R which produces heat. The switch is generally enclosed in hydrogen-filled glass bulb G . The two switch electrodes $E1$ and $E2$ are normally closed when the lamp is not in operation. When normal supply is switched on, the lamp filament electrodes A and B are connected together

through the thermal switch and a large current passes through them. Consequently, they are heated to incandescence. Meanwhile heat produced in resistance R causes the bimetallic strip $E2$ to break contact. The inductive surge of about 1000 V produced by the choke is sufficient to start discharge through mercury vapours as explained in Art. 3.27. The heat produced in R keeps the switch contacts

$E1$ and $E2$ open during the time lamp is in operation.

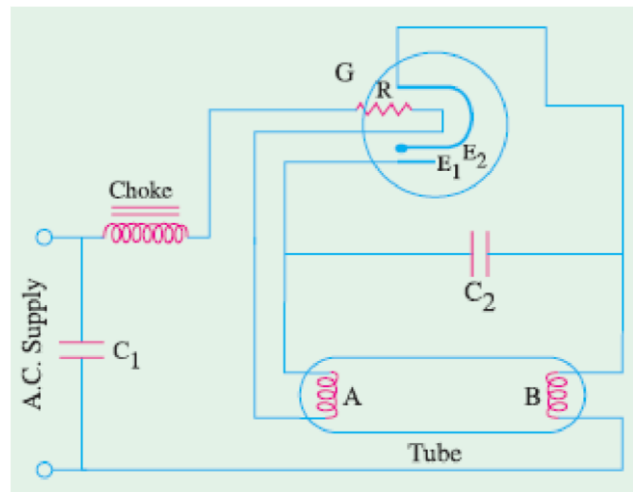

Fig. 49.52

Comparison of Different Light Sources

1. Incandescent Lamps. They have instantaneous start and become momentarily off when the supply goes off. The colour of their light is very near the natural light. Their initial cost of installation is minimum but their running cost is maximum. They work equally well both on d.c. and a.c. supply and frequent switching does not affect their life of operation. Change of supply voltage affects their efficiency, output and life in a very significant way. They have an average working life of 1000 hours and luminous efficiency of 12 lm/W. Since their light has no stroboscopic effects, the incandescent lamps are suitable for domestic, industrial, street lighting and floodlights etc. They are available in a wide range of voltage ratings and, hence are used in automobiles, trains, emergency lights, aeroplanes and signals for railways etc.

2. Fluorescent Lamps. They have a reaction time of one second or a little more at the start. They go off and restart when the supply is restored. The colour of their light varies with the phosphor coating. Their initial cost of installation is maximum but running cost is minimum. Since stroboscopic effect is present, they are suitable for semi-direct lighting, domestic, industrial, commercial, roads and halls etc. Change in voltage affects their starting although light output does not change as remarkably as in the case of incandescent lamps. Colour of their light changes with the different phosphor coating on the inner side of the tube. Frequent switching affects their life period. They have quite high utility but their voltage rating is limited. Hence, their use is confined to mains voltage or complicated inverter circuits which convert 12

V d.c. into high volt d.c.. They have an average working life of 4000 hours and a luminous efficiency of 40 lm/W.

3. Mercury Vapour Lamps. They take 5 to 6 minutes for starting. They go off and cannot be restarted after the recovery of the voltage till the pressure falls to normal. They suffer from high colour distortion. Their initial cost of installation is high but lesser than that of fluorescent lamps. Their running cost is much less than incandescent lamps but higher than fluorescent tubes for the same levels of illumination. Stroboscopic effect is present in their light. They are suitable for open space like yards, parks and highway lighting etc. Change in voltage affects their starting time and colour of radiations emitted by them. Switching does not affect their life period. They have very limited utility that too on mains voltage. They are suitable for vertical position of working. They have an average working life of 3000 hours and an efficiency of 40 lm/W.

4. Sodium Vapour Lamps. They have a starting time of 5 to 6 minutes. They go off and cannot be restarted after the recovery of the voltage till its value falls to the normal value. The colour of their light is yellowish and produces colour distortion. Their initial cost of installation is maximum although their running cost is less than for filament lamps but more than for fluorescent lamps. They have stroboscopic effect and are suitable for use in open spaces, highways and street lighting etc. Change in voltage affects their starting time and colour of their radiations. They work on a.c. voltage and frequent switching affects their life. They are not suitable for local lighting. The colour of their light cannot be changed. They are very suitable for street lighting purposes. Their position of working is horizontal. They have a working life of about 3000 hours and efficiency of 60-70 lm/W.

Expected Questions

1. A directly beneath the source. How far is B from A if the illumination at B is only $1/10$ as great as at A? Let the intensity of the lamp be I and the distance between A and B be x metres as shown in

Illumination at point A, $E_A = I/10^2 = I/100$ lux Illumination at point B,

2. A corridor is lighted by 4 lamps spaced 10 m apart and suspended at a height of 5 m above the centre line of the floor. If each lamp gives 200 C.P. in all directions below the horizontal, find the illumination at the point on the floor mid-way between the second and third lamps.
3. Two lamps A and B of 200 candela and 400 candela respectively are situated 100 m apart. The height of A above the ground level is 10 m and that of B is 20 m. If a photometer is placed at the centre of the line joining the two lamp posts, calculate its reading.

Solution: When the illumination photometer is placed at the centre point, it will read the value of combined illumination produced by the two lamps

4. The average luminous output of an 80-W fluorescent lamp 1.5 metre in length and 3.5 cm diameter is 3300 lumens. Calculate its average brightness. If the auxiliary gear associated with the lamp consumes a load equivalent to 25 percent of the lamp, calculate the cost of running a twin unit for 2500 hours at 30 paise per kWh.
5. A small area 7.5 m in diameter is to be illuminated by a lamp suspended at a height of 4.5 m over the centre of the area. The lamp having an efficiency of 20 lm/w is fitted with a reflector which directs the light output only over the surface to be illuminated, giving uniform candle power over this angle. Utilisation coefficient = 0.40. Find out the wattage of the lamp. Assume 800 lux of illumination level from the lamp.
6. A room 8 m × 12 m is lighted by 15 lamps to a fairly uniform illumination of 100 lm/m². Calculate the utilization coefficient of the room given that the output of each lamp is 1600 lumens.
7. The illumination in a drawing office 30 m × 10 m is to have a value of 250 lux and is to be provided by a number of 300-W filament lamps. If the coefficient of utilization is 0.4 and the depreciation factor 0.9, determine the number of lamps required. The luminous efficiency of each lamp is 14 lm/W
8. Find the total saving in electrical load and percentage increase in illumination if instead of using twelve 150 W tungsten-filament lamps, we use twelve 80 W fluorescent tubes. It may be assumed that (i) there is a choke loss of 25 per cent of rated lamp wattage (ii) average luminous efficiency

throughout life for each lamp is 15 lm/W and for each tube 40 lm/W and (iii) coefficient of utilization remains the same in both cases

9. A football pitch $120\text{ m} \times 60\text{ m}$ is to be illuminated for night play by similar banks of equal 1000 W lamps supported on twelve towers which are distributed around the ground to provide approximately uniform illumination of the pitch. Assuming that 40% of the total light emitted reaches the playing pitch and that an illumination of 1000 lm/m^2 is necessary for television purposes, calculate the number of lamps on each tower. The overall efficiency of the lamp is to be taken as 30 lm/W .
10. If the filament of a 32 candela, 100-V lamp has a length l and diameter d , calculate the length and diameter of the filament of a 16 candela 200-V lamp, assuming that the two lamps run at the same intrinsic brilliance.
11. An incandescent lamp has a filament of 0.005 cm diameter and one metre length. It is required to construct another lamp of similar type to work at double the supply voltage and give half the candle power. Assuming that the new lamp operates at the same brilliancy, determine suitable dimensions for its filament.
12. A 60 candle power, 250-V metal filament lamp has a measured candle power of 71.5 candela at 260 V and 50 candela at 240 V. (a) Find the constant for the lamp in the expression $C = aV^b$ where $C =$ candle power and $V =$ voltage. (b) Calculate the change of candle power per volt at 250 V. Determine the percentage variation of candle power due to a voltage variation of $\pm 4\%$ from the normal value.

PART B

UNIT-5, 6 & 7

ELECTRIC TRACTION

Introduction: By electric traction is meant locomotion in which the driving (or tractive) force is obtained from electric motors. It is used in electric trains, tramcars, trolley buses and diesel-electric vehicles etc.

Electric traction has many advantages as compared to other non-electrical systems of traction including steam traction.

Traction Systems

Broadly speaking, all traction systems may be classified into two categories :

(a) Non-electric traction systems

They do not involve the use of electrical energy at *any stage*. Examples are : steam engine drive used in railways and internal-combustion-engine drive used for road transport.

(b) Electric traction systems

They involve the use of electric energy at some stage or the other. They may be further subdivided into two groups :

1. First group consists of self-contained vehicles or locomotives. Examples are : battery-electric drive and diesel-electric drive etc.
2. Second group consists of vehicles which receive electric power from a distribution network fed at suitable points from either central power stations or suitably-spaced sub-stations.

Examples are : railway electric locomotive fed from overhead ac supply and tramways and trolley buses supplied with dc supply.

Direct Steam Engine Drive

Though losing ground gradually due to various reasons, steam locomotive is still the most widely adopted means of propulsion for railway work. Invariably, the reciprocating engine is employed because

1. it is inherently simple.
2. connection between its cylinders and the driving wheels is simple.
3. its speed can be controlled very easily.

However, the steam locomotive suffers from the following disadvantages :

1. since it is difficult to install a condenser on a locomotive, the steam engine runs non-condensing and, therefore, has a very low thermal efficiency of about 6-8 percent.
2. it has strictly limited overload capacity.
3. it is available for hauling work for about 60% of its working days, the remaining 40% being spent in preparing for service, in maintenance and overhaul.

Diesel-electric Drive

It is a self-contained motive power unit which employs a diesel engine for direct drive of a dc generator. This generator supplies current to traction motors which are geared to the driving axles. In India, diesel locomotives were introduced in 1945 for shunting service on broad gauge (BG) sections and in 1956 for high-speed main-line operations on metre-gauge (MG) sections. It was only in 1958 that Indian Railways went in for extensive main-line dieselisation.* Diesel-electric traction has the following advantages :

1. no modification of existing tracks is required while converting from steam to diesel-electric traction.
2. it provides greater tractive effort as compared to steam engine which results in higher starting acceleration.
3. it is available for hauling for about 90% of its working days.
4. diesel-electric locomotive is more efficient than a steam locomotive (though less efficient than an electric locomotive). **Disadvantages**

1. for same power, diesel-electric locomotive is costlier than either the steam or electric locomotive.
2. overload capacity is limited because diesel engine is a constant-kW output prime mover.
3. life of a diesel engine is comparatively shorter.

4. diesel-electric locomotive is heavier than plain electric locomotive because it carries the main engine, generator and traction motors etc.
5. regenerative braking cannot be employed though rheostatic braking can be.

Battery-electric Drive

In this case, the vehicle carries secondary batteries which supply current to dc motors used for driving the vehicle. Such a drive is well-suited for shunting in railway yards, for traction in mines, for local delivery of goods in large towns and large industrial plants. They have low maintenance cost and are free from smoke. However, the scope of such vehicles is limited because of the small capacity of the batteries and the necessity of charging them frequently.

Advantages of Electric Traction

As compared to steam traction, electric traction has the following advantages :

1. Cleanliness. Since it does not produce any smoke or corrosive fumes, electric traction is most suited for underground and tube railways. Also, it causes no damage to the buildings and other apparatus due to the absence of smoke and flue gases.

2. Maintenance Cost. The maintenance cost of an electric locomotive is nearly 50% of that for a steam locomotive. Moreover, the maintenance time is also much less.

3. Starting Time. An electric locomotive can be started at a moment's notice whereas a steam locomotive requires about two hours to heat up.

4. High Starting Torque. The motors used in electric traction have a very high starting torque. Hence, it is possible to achieve higher accelerations of 1.5 to 2.5 km/h/s as against 0.6 to 0.8 km/h/s in steam traction. As a result, we are able to get the following additional advantages:

(i) high schedule speed

(ii) increased traffic handling capacity

(iii) because of (i) and (ii) above, less terminal space is required—a factor of great importance in urban areas.

5. Braking. It is possible to use regenerative braking in electric traction system. It leads to the following advantages :

- (i) about 80% of the energy taken from the supply during ascent is returned to it during descent.
- (ii) goods traffic on gradients becomes safer and speedier.
- (iii) since mechanical brakes are used to a very small extent, maintenance of brake shoes, wheels, tyres and track rails is considerably reduced because of less wear and tear.

6. Saving in High Grade Coal. Steam locomotives use costly high-grade coal which is not so abundant. But electric locomotives can be fed either from hydroelectric stations or pit-head thermal power stations which use cheap low-grade coal. In this way, high-grade coal can be saved for metallurgical purposes.

7. Lower Centre of Gravity. Since height of an electric locomotive is much less than that of a steam locomotive, its centre of gravity is comparatively low. This fact enables an electric locomotive to negotiate curves at higher speeds quite safely.

8. Absence of Unbalanced Forces. Electric traction has higher coefficient of adhesion since there are no unbalanced forces produced by reciprocating masses as is the case in steam traction. It not only reduces the weight/kW ratio of an electric locomotive but also improves its riding quality in addition to reducing the wear and tear of the track rails.

Disadvantages of Electric Traction

1. The most vital factor against electric traction is the initial high cost of laying out overhead electric supply system. Unless the traffic to be handled is heavy, electric traction becomes uneconomical.
2. Power failure for few minutes can cause traffic dislocation for hours.
3. Communication lines which usually run parallel to the power supply lines suffer from electrical interference. Hence, these communication lines have either to be removed away from the rail track or else underground cables have to be used for the purpose which makes the entire system still more expensive.
4. Electric traction can be used only on those routes which have been electrified. Obviously, this restriction does not apply to steam traction.

5. Provision of a negative booster is essential in the case of electric traction. By avoiding the flow of return currents through earth, it curtails corrosion of underground pipe work and interference with telegraph and telephone circuits.

Systems of Railway Electrification

Presently, following four types of track electrification systems are available:

1. Direct current system—600 V, 750 V, 1500 V, 3000 V
2. Single-phase ac system—15-25 kV, 16 23, 25 and 50 Hz
3. Three-phase ac system—3000-3500 V at 16 2 3 Hz
4. Composite system—involving conversion of single-phase ac into 3-phase ac or dc.

Direct Current System

Direct current at 600-750 V is universally employed for tramways in urban areas and for many suburban railways while 1500-3000 V dc is used for main line railways. The current collection is from third rail (or conductor rail) up to 750 V, where large currents are involved and from overhead wire for 1500 V and 3000 V, where small currents are involved. Since in majority of cases, track (or running) rails are used as the return conductor, only one conductor rail is required. Both of these contact systems are fed from substations which are spaced 3 to 5 km for heavy suburban traffic and 40-50 km for main lines operating at higher voltages of 1500 V to 3000 V. These sub-stations themselves receive power from 110/132 kV, 3-phase network (or grid). At these substations, this high-voltage 3-phase supply is converted into low-voltage 1-phase supply with the help of Scott connected or V-connected 3-phase transformers (Art. 31.9). Next, this low ac voltage is converted into the required dc voltage by using suitable rectifiers or converters (like rotary converter, mercury arc,

metal or semiconductor rectifiers). These substations are usually automatic and are remote controlled.

The dc supply so obtained is fed via suitable contact system to the traction motors which are either dc series motors for electric locomotive or compound motors for tramway and trolley buses where regenerative braking is desired.

It may be noted that for *heavy suburban service*, low voltage dc system is undoubtedly superior to 1-phase ac system due to the following reasons:

1. dc motors are better suited for frequent and rapid acceleration of heavy trains than ac motors.
2. dc train equipment is lighter, less costly and more efficient than similar ac equipment.
3. when operating under similar service conditions, dc train consumes less energy than a 1-phase ac train.
4. the conductor rail for dc distribution system is less costly, both initially and in maintenance than the high-voltage overhead ac distribution system.
5. dc system causes no electrical interference with overhead communication lines.

The only disadvantage of dc system is the necessity of locating ac/dc conversion sub-stations at relatively short distances apart.

Single-Phase Low-frequency AC System

In this system, ac voltages from 11 to 15 kV at 23 16 or 25 Hz are used. If supply is from a generating station exclusively meant for the traction system, there is no difficulty in getting the electric supply of 23 16 or 25 Hz. If, however, electric supply is taken from the high voltage transmission lines at 50 Hz, then in addition to step-down transformer, the substation is provided with a frequency converter. The frequency converter equipment consists of a 3-phase synchronous motor which drives a I-phase alternator having or 25 Hz frequency.

The 15 kV 23 16 or 25 Hz supply is fed to the electric locomotors via a single over-head wire (running rail providing the return path).

A step-down transformer carried by the locomotive reduces the 15-kV voltage to 300-400 V for feeding the ac series motors. Speed regulation of ac series motors is achieved by applying variable voltage from the tapped secondary of the above transformer. Low-frequency ac supply is used because apart from improving the commutation properties of ac motors, it increases their efficiency and power factor. Moreover, at low frequency, line reactance is less so that line impedance drop and hence line voltage drop is reduced. Because of this reduced line drop, it is feasible to space the substations 50 to 80 k

Three-phase Low-frequency AC System

It uses 3-phase induction motors which work on a 3.3 kV, 23 16 Hz supply. Sub-stations receive power at a very high voltage from 3-phase transmission lines at the usual industrial frequency of 50 Hz. This high voltage is stepped down to 3.3 kV by transformers whereas frequency is reduced from 50 Hz to 23 16 Hz by frequency converters installed at the substations. Obviously, this system employs *two* overhead contact wires, the track rail forming the third phase (of course, this leads to insulation difficulties at the junctions). Induction motors used in the system are quite simple and robust and give trouble-free operation.

They possess the merits of high efficiency and of operating as a generator when driven at speeds above the synchronous speed. Hence, they have the property of automatic regenerative braking during the descent on gradients. However, it may be noted that despite all its advantages, this system has not found much favor and has; in fact, become obsolete because of its certain inherent limitations given below:

1. The overhead contact wire system becomes complicated at crossings and junctions.
2. constant-speed characteristics of induction motors are not suitable for traction work.
3. Induction motors have speed/torque characteristics similar to dc shunt motors. Hence, they are not suitable for parallel operation because, even with little difference in rotational speeds caused by unequal diameters of the wheels, motors will become loaded very unevenly.

Composite System

Such a system incorporates good points of two systems while ignoring their bad points. Two such composite systems presently in use are:

1. 1-phase to 3-phase system also called Kando system
2. 1-phase to dc system.

Kando System

In this system, single-phase 16-kV, 50 Hz supply from the sub-station is picked up by the locomotive through the single overhead contact wire. It is then converted into 3-phase ac supply at the same frequency by means of phase converter equipment carried on the locomotives. This 3-phase supply is then fed to the 3-phase induction motors.

As seen, the complicated overhead two contact wire arrangement of ordinary 3-phase system is replaced by a single wire system. By using silicon controlled rectifier as inverter, it is possible to get variable-frequency 3-phase supply at 1/2 to 9 Hz frequency. At this low frequency, 3-phase motors develop high starting torque without taking excessive current. In view of the above, Kando system is likely to be developed further.

Single-phase AC to DC System

This system combines the advantages of high-voltage ac distribution at industrial frequency with the dc series motors traction. It employs overhead 25-kV, 50-Hz supply which is stepped down by the transformer installed in the locomotive itself. The low-voltage ac supply is then converted into dc supply by the rectifier which is also carried on the locomotive. This dc supply is finally fed to dc series traction motor fitted between the wheels. The system of traction employing 25-kV, 50-Hz, 1phase ac supply has been adopted for all future track electrification in India.

Advantages of 25-kV, 50-Hz AC System

Advantages of this system of track electrification over other systems particularly the dc system are as under :

1. Light Overhead Catenary

Since voltage is high (25 kV), line current for a given traction demand is less. Hence, crosssection of the overhead conductors is reduced. Since these small-sized conductors are light, supporting structures and foundations are also light and simple. Of course, high voltage needs higher insulation which increases the cost of overhead equipment (OHE) but the reduction in the size of conductors has an overriding effect.

2. Less Number of Substations

Since in the 25-kV system, line current is less, line voltage drop which is mainly due to the resistance of the line is correspondingly less. It improves the voltage regulation of the line which fact makes larger spacing of 50-80 km between sub-stations possible as against 5-15 km with 1500 V dc system and 15-30 km with 3000 V dc system. Since the required number of substations along the track is considerably reduced, it leads to substantial saving in the capital expenditure on track electrification.

3. Flexibility in the Location of Substations

Larger spacing of substations leads to greater flexibility in the selection of site for their proper location. These substations can be located near the national high-voltage grid which, in our country,

fortunately runs close to the main railway routes. The substations are fed from this grid thereby saving the railway administration lot of expenditure for erecting special transmission lines for their substations. On the other hand, in view of closer spacing of dc substations and their far away location, railway administration has to erect its own transmission lines for taking feed from the national grid to the substations which consequently increases the initial cost of electrification.

4. Simplicity of Substation Design

In ac systems, the substations are simple in design and layout because they do not have to install and maintain rotary converters or rectifiers as in dc systems. They only consist of static transformers alongwith their associated switchgear and take their power directly from the high-voltage national grid running over the length and breadth of our country. Since such sub-stations are remotely controlled, they have few attending personnel or even may be unattended.

5. Lower Cost of Fixed Installations

The cost of fixed installations is much less for 25 kV ac system as compared to dc system. In fact, cost is in ascending order for 25 kV ac, 3000 V dc and 1500 V dc systems. Consequently, traffic densities for which these systems are economical are also in the ascending order

6. Higher Coefficient of Adhesion

The straight dc locomotive has a coefficient of adhesion of about 27% whereas its value for ac rectifier locomotive is nearly 45%. For this reason, a lighter ac locomotive can haul the same load as a heavier straight dc locomotive. Consequently, ac locomotives are capable of achieving higher speeds in coping with heavier traffic.

7. Higher Starting Efficiency

An ac locomotive has higher starting efficiency than a straight dc locomotive. In dc locomotive supply voltage at starting is reduced by means of ohmic resistors but by on-load primary or secondary tap-changer in ac locomotives.

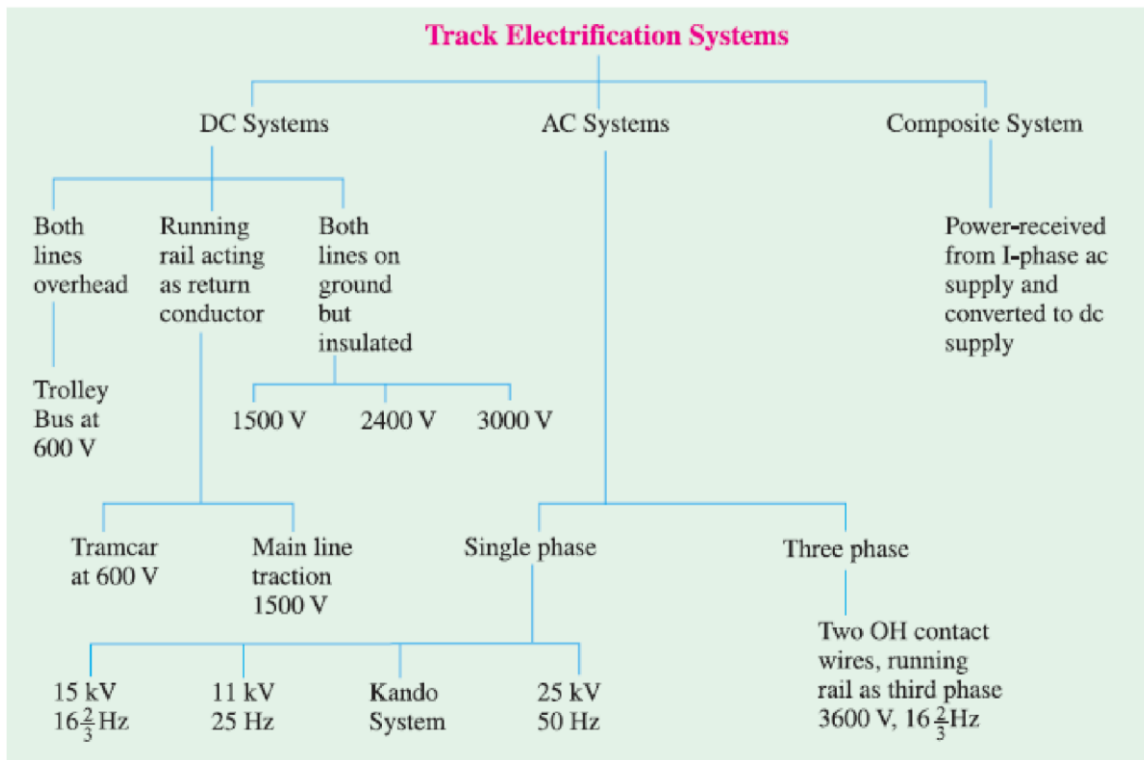

Block Diagram of an AC Locomotive

The various components of an ac locomotive running on single-phase 25-kV, 50-Hz ac supply are numbered in Fig. 43.1.

1. OH contact wire
2. pantograph
3. circuit breakers
4. on-load tap-changers
5. transformer
6. rectifier
7. smoothing choke
8. dc traction motors.

As seen, power at 25 kV is taken via a pantograph from the overhead contact wire and fed to the step-down transformer in the locomotive. The low ac voltage so obtained is converted into pulsating dc voltage by means of the rectifier. The pulsations in the dc voltage are then removed by the smoothing choke before it is fed to dc series traction motors which are mounted between the wheels. The function of circuit breakers is to immediately disconnect the locomotive from the overhead supply in case of any fault in its electrical system. The on-load tap-changer is used to change the **1.** voltage across the motors and hence regulate their speed.

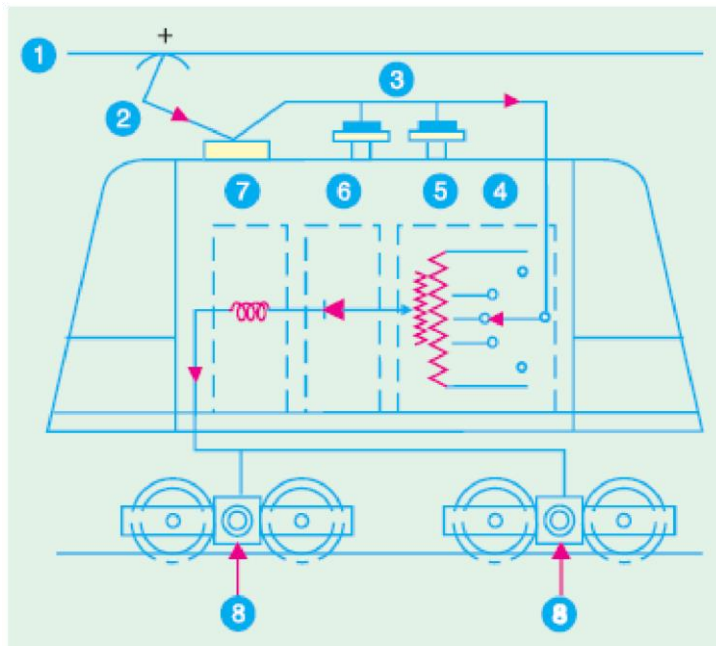

Fig. 43.1

The Tramways

It is the most economical means of transport for very dense traffic in the congested streets of large cities. It receives power through a bow collector or a grooved wheel from an overhead conductor at about 600 V dc, the running rail forming the return conductor. It is provided with at least two driving axles in order to (i) secure necessary adhesion (ii) start it from either end and (iii) use two motors with series-parallel control. Two drum-type controllers, one at each end, are used for controlling the tramcar. Though these controllers are connected in parallel, they have suitable interlocking arrangement meant to prevent their being used simultaneously.

Tramcars are being replaced by trolley-buses and internal-combustion-engined omnibuses because of the following reasons :

1. tramcars lack flexibility of operation in congested areas.
2. the track constitutes a source of danger to other road users.

The Trolleybus

It is an electrically-operated pneumatic-tyred vehicle which needs *no track in the roadway*. It receives its power at 600 V dc from two overhead contact wires. Since adhesion between a rubber-tyred wheel and ground is sufficiently high, only a single driving axle and, hence, a single motor is used. The trolleybus can manoeuvre through traffic a metre or two on each side of the centre line of the trolley wires

Overhead Equipment (OHE)

Broadly speaking, there are two systems of current collection by a traction unit :

(i) third rail system and (ii) overhead wire system.

It has been found that current collection from overhead wire is far superior to that from the third rail. Moreover, insulation of third rail at high voltage becomes an impracticable proposition and endangers the safety of the working personnel.

The simplest type of OHE consists of a single contact wire of hard drawn copper or silico-bronze supported either by bracket or an overhead span. To facilitate connection to the supports, the wire is grooved as shown in Fig. 43.2. Because there is appreciable sag of the wire between supports, it limits the speed of the traction unit to about 30 km/h. Hence, single contact wire system is suitable for tramways and in complicated yards and terminal stations where speeds are low and simplicity of layout is desirable.

For collection of current by high-speed trains, the contact (or trolley) wire has to be kept level without any abrupt changes in its height between the supporting structures. It can be done by using the single catenary system which consists of one catenary or messenger wire of steel with high sag and the trolley (or contact) wire supported from messenger wire by means of droppers clipped to both wires as shown in Fig. 43.3.

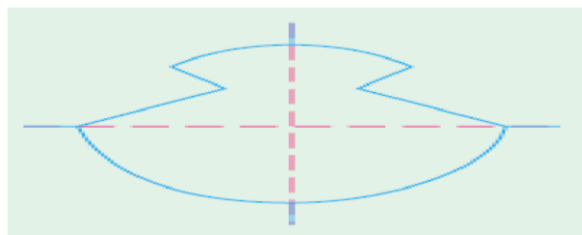

Fig. 43.2

Collector Gear for OHE

The most essential requirement of a collector is that it should keep continuous contact with trolley wire at all speeds. Three types of gear are in common use :

1. trolley collector
2. bow collector
3. pantograph collector.

To ensure even pressure on OHE, the gear equipment must, be flexible in order to follow variations in the sag of the contact wire. Also, reasonable precautions must be taken to prevent the collector from leaving the overhead wire at points and crossings.

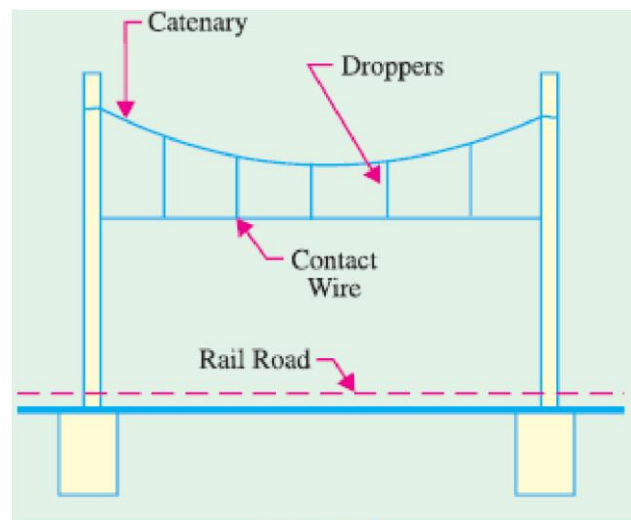
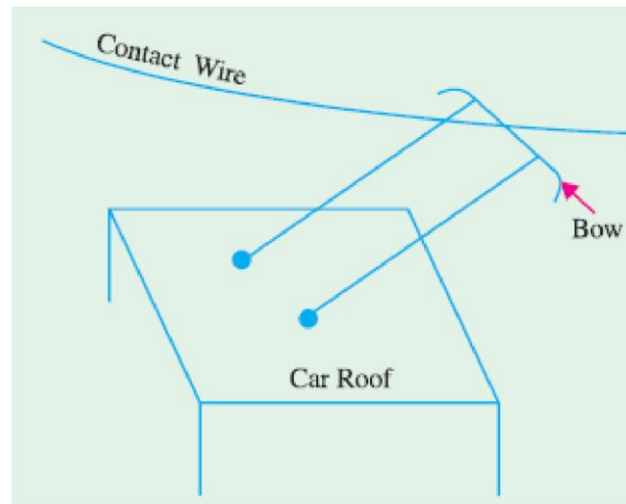

Fig. 43.3

The Trolley Collector

This collector is employed on tramways and trolley buses and is mounted on the roof of the vehicle. Contact with the OH wire is made by means of either a grooved wheel or a sliding shoe carried at the end of a light trolley pole attached to the top of the vehicle and held in contact with OH wire by means of a spring. The pole is hinged to a swivelling base so that it may be reversed for reverse running thereby making it unnecessary for the trolley wire to be accurately maintained above the centre of the track. Trolley collectors always operate in the trailing position. The trolley collector is suitable for low speeds upto 32 km/h beyond which there is a risk of its jumping off the OH contact wire particularly at points and crossing.

The Bow Collector It can be used for higher speeds. As shown in Fig. 43.4, it consists of two roofmounted trolley poles at the ends of which is placed a light metal strip (or bow) about one metre long for current collection. The collection strip is purposely made of soft material (copper, aluminium or carbon) in order that most of the wear may occur on it rather than on the trolley wire. The bow collector also operates in the trailing position. Hence, it requires provision of either duplicate bows or an arrangement for reversing the bow for running in the reverse direction. Bow collector is not suitable for railway work where speeds up to 120 km/h and currents up to 3000 A are encountered. It is so because the inertia of the bow collector is too high to ensure satisfactory current collection.



d

Fig. 43.4

The Pantograph Collector

Its function is to maintain link between overhead contact wire and power circuit of the electric locomotive at different speeds under all wind conditions and stiffness of OHE. It means that positive pressure has to be maintained at all times to avoid loss of contact and sparking but the pressure must be as low as possible in order to minimize wear of OH contact wire. A 'diamond' type single-pan pantograph is shown in Fig. 43.5. It consists of a pentagonal framework of high-tensile alloy-steel tubing. The contact portion consists of a pressed steel pan fitted with renewable copper wearing strips which are forced against the OH contact wire by the upward action of pantograph springs. The pantograph can be raised or lowered from cabin by air cylinders.

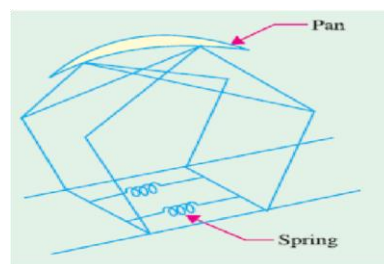

Fig. 43.5

Train Movement

The movement of trains and their energy consumption can be conveniently studied by means of speed/time and speed/distance curves. As their names indicate, former gives speed of the train at

various *times* after the start of the run and the later gives speed at various *distances* from the starting point. Out of the two, speed/time curve is more important because

1. its slope gives acceleration or retardation as the case may be.
2. area between it and the horizontal (*i.e.* time) axis represents the distance travelled.
3. energy required for propulsion can be calculated if resistance to the motion of train is known.

Typical Speed/Time Curve

Typical speed/time curve for electric trains operating on passenger services is shown in Fig. 43.8. It may be divided into the following **five** parts :

1. Constant Acceleration Period (0 to t_1)

It is also called notching-up or starting period because during this period, starting resistance of the motors is gradually cut out so that the motor current (and hence, tractive effort) is maintained nearly constant which produces constant acceleration alternatively called ‘rheostatic acceleration’ or ‘acceleration while notching’.

2. Acceleration on Speed Curve

(t_1 to t_2)

This acceleration commences after the starting resistance has been all cutout at point t_1 and full supply voltage has been applied to the motors. During this period, the motor current and torque decrease as train speed increases. Hence, acceleration gradually *decreases* till torque developed by motors exactly balances that due to resistance to the train motion. The shape of the portion *AB* of the speed/time curve depends primarily on the torque/speed characteristics of the traction motors.

3. Free-running Period (t_2 to t_3)

The train continues to run at the speed reached at point t_2 . It is represented by portion *BC* in Fig. 43.8 and is a constant-speed period which occurs on level tracks.

4. Coasting (t_3 to t_4)

Power to the motors is cut off at point t_3 so that the train runs under its momentum, the speed gradually falling due to friction, windage etc. (portion *CD*). During this period, retardation remains practically constant. Coasting is desirable because it utilizes some of the kinetic energy of the train which would, otherwise, be wasted during braking. Hence, it helps to reduce the energy consumption of the train.

5. Braking (t_4 to t_5)

At point t_4 , brakes are applied and the train is brought to rest at point t_5 .

It may be noted that coasting and braking are governed by train resistance and allowable retardation respectively.

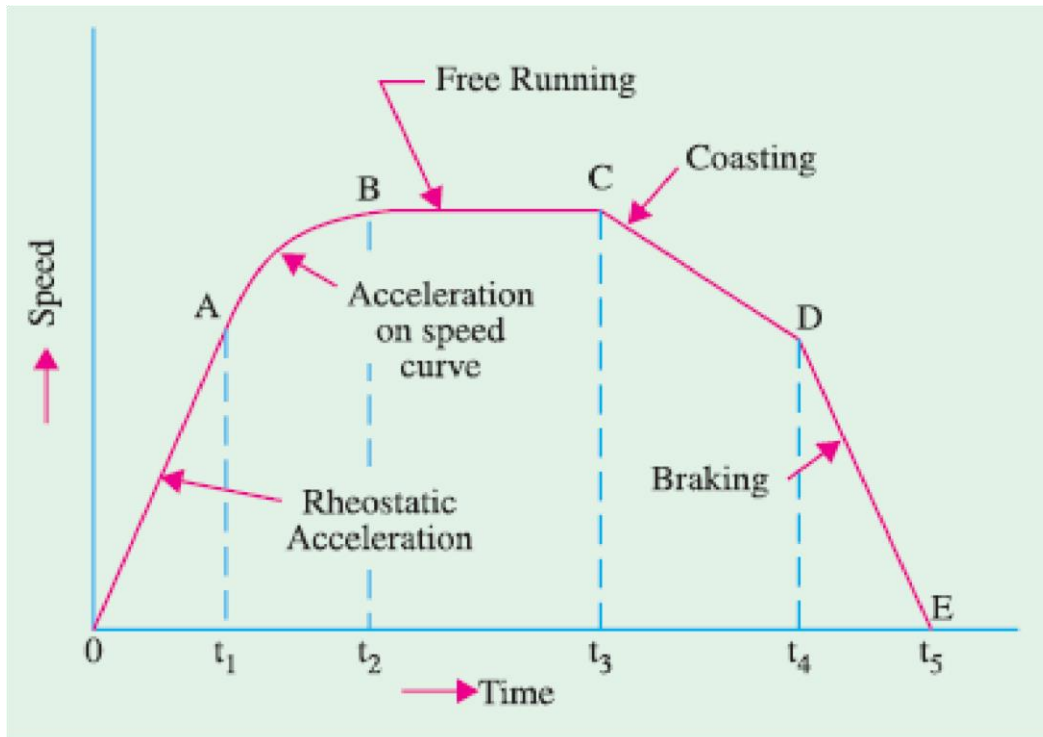

Fig. 43.8

Speed/Time Curves for Different Services

Fig. 43.9 (a) is representative of city service where relative values of acceleration and retardation are high in order to achieve moderately high average speed between stops. Due to short

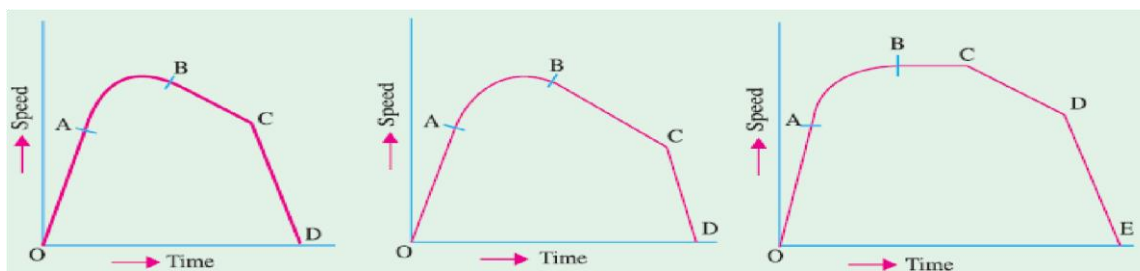

Fig. 43.9

Distances between stops, there is no possibility of free-running period though a short coasting period is included to save on energy consumption.

In suburban services [Fig. 43.9 (b)], again there is no free-running period but there is comparatively *longer* coasting period because of longer distances between stops. In this case also, relatively high

values of acceleration and retardation are required in order to make the service as attractive as Possible.

For main-line service [Fig. 43.9 (c)], there are long periods of free-running at high speeds. The accelerating and retardation periods are relatively unimportant.

Simplified Speed/Time Curve

For the purpose of comparative performance for a given service, the actual speed/time curve of Fig. 43.8 is replaced by a simplified speed/time curve which does not involve the knowledge of motor characteristics. Such a curve has simple geometric shape so that simple mathematics can be used to find the relation between acceleration, retardation, average speed and distance etc. The simple curve would be fairly accurate provided it (i) *retains the same acceleration and retardation and (ii) has The same area as the actual speed/time curve*. The simplified speed/time curve can have either of the two shapes:

(i) trapezoidal shape $OA1B1C$ of Fig. 43.10 where speed-curve running and coasting periods of the actual speed/time curve have been replaced by a constant speed period.

(ii) Quadrilateral shape $OA2B2C$ where the same two periods are replaced by the extensions of initial constant acceleration and coasting periods. It is found that trapezoidal diagram $OA1B1C$ gives simpler relationships between the principal quantities involved in train movement and also gives closer approximation of actual energy consumed during *main-line service on level track*. On the other hand, quadrilateral diagram approximates more closely to the actual conditions in *city and suburban services*.

Average and Schedule Speed

While considering train movement, the following three speeds are of importance :

1. Crest Speed. It is the maximum speed (V_m) attained by a train during the run.

2. Average Speed = distance between stops actual time of run

In this case, only running time is considered but *not the stop time*.

3. Schedule Speed = distance between stops actual time of run + stop time

Obviously, schedule speed can be obtained from average speed by including the duration of stops.

For a given distance between stations, higher values of acceleration and retardation will mean lesser

running time and, consequently, higher schedule speed. Similarly, for a given distance between stations and for fixed values of acceleration and retardation, higher crest speed will result in higher schedule speed. For the same value of average speed, increase in duration of stops decreases the schedule speed.

SI Units in Traction Mechanics

In describing various quantities involved in the mechanics of train movement, only the latest SI system will be used. Since SI system is an ‘absolute system’, only absolute units will be used while gravitational units (used hitherto) will be discarded.

1. Force. It is measured in newton (N)

2. Mass. Its unit is kilogram (kg). Commonly used bigger units is tonne (*t*), 1 tonne = 1000 kg

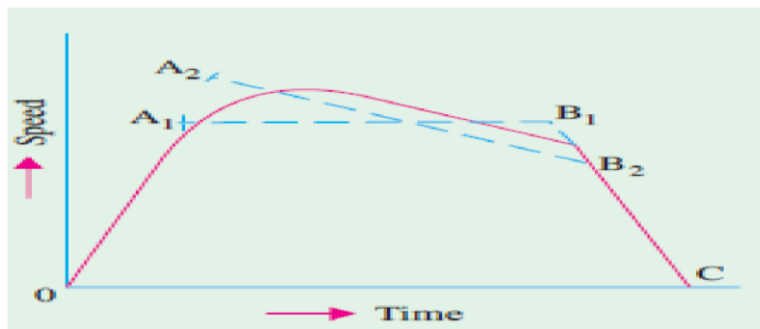

Fig. 43.10

3. Energy. Its basic unit is joule (J). Other units often employed are watt-hour (Wh) and kilowatt-hour (kWh).

$$1 \text{ Wh} = 1 \text{ J/s} \times 3600 \text{ s} = 3600 \text{ J} = 3.6 \text{ kJ}$$

$$1 \text{ kWh} = 1000 \text{ Wh} = 1000 \times 3600 \text{ J} = 36 \times 10^5 \text{ J} = 3.6 \text{ MJ}$$

4. Work. Its unit is the same as that of energy.

5. Power. Its unit is watt (W) which equals 1 J/s. Other units are kilowatt (kW) and megawatt (MW).

6. Distance. Its unit is metre. Other unit often used is kilometre (km).

7. Velocity. Its absolute unit is metre per second (m/s). If velocity is given in km/h (or km.ph), it can be easily converted into the SI unit of m/s by multiplying it with a factor of

$$(1000/3600) = 5/18 = 0.2778. \text{ For example, } 72 \text{ km.ph} =$$

$$72 \times 5/18 = 72 \times 0.2778 = 20 \text{ m/s.}$$

8. Acceleration. Its unit is metre/second² (m/s²). If acceleration is given in km/h/s (or kmph. ps), then it can be converted into m/s² by simply multiplying it by the factor $(1000/3600) = 5/18 = 0.2778$ *i.e.* the same factor as for velocity.

For example, 1.8 km.ph.ps = $1.8 \times \frac{5}{18} = 1.8 \times 0.2778 = 0.5 \text{ m/s}^2$

Quantities Involved in Traction Mechanics

Following principal quantities are involved in train movement :

D = distance between stops

M = dead mass of the train

M_e = effective mass of the train

W = dead weight of the train W_e =

effective weight of the train α =

acceleration during starting period β =

retardation during coasting β =

retardation during braking

V_a = average speed

V_m = maximum (or crest) speed.

t = total time for the run t_1 = time of acceleration t_2 = time of free running = $t - (t_1 + t_3)$ t_3 = time of braking

F_t = tractive effort

T = torque

Relationship Between Principal Quantities in Trapezoidal Diagram

As seen from Fig. 43.11.

$\alpha = V_m / t_1$ or $t_1 = V_m / \alpha$

$\beta = V_m / t_3$ or $t_3 = V_m / \beta$

As we know, total distance D between the two stops is given by the area of trapezium $OABC$. therefore

$D = \text{area } OABC$

= area OAD + area $ABED$ + area BCE

$$= \frac{1}{2} V_m t_1 + V_m t_2 + \frac{1}{2} V_m t_3$$

$$= \frac{1}{2} V_m t_1 + V_m [t - (t_1 + t_3)] + \frac{1}{2} V_m t_3$$

$$= V_m \left[\frac{t_1}{2} + t - t_1 - t_3 + \frac{t_3}{2} \right]$$

$$= V_m \left[t - \frac{1}{2} (t_1 + t_3) \right]$$

$$= V_m \left[t - \frac{V_m}{2} \left(\frac{1}{\alpha} + \frac{1}{\beta} \right) \right]$$

Let, $K = \frac{1}{2} \left(\frac{1}{\alpha} + \frac{1}{\beta} \right)$. Substituting this value

of K in the above equation, we get

$$D = V_m (t - KV_m)$$

or $KV_m^2 - V_m t + D = 0$... (i)

$$\therefore V_m = \frac{t \pm \sqrt{t^2 - 4KD}}{2K}$$

Rejecting the positive sign which gives impracticable value, we get

$$V_m = \frac{t \pm \sqrt{t^2 - 4KD}}{2K}$$

From Eq. (i) above, we get

$$KV_m^2 = V_m t - D \quad \text{or} \quad K = \frac{t}{V_m} - \frac{D}{V_m^2} = \frac{D}{V_m^2} \left(V_m \cdot \frac{t}{D} - 1 \right)$$

Now, $V_a = \frac{D}{t} \quad \therefore \quad K = \frac{D}{V_m^2} \left(\frac{V_m}{V_a} - 1 \right)$

Obviously, if V_m , V_a and D are given, then value of K and hence of α and β can be found (Ex. 43.2).

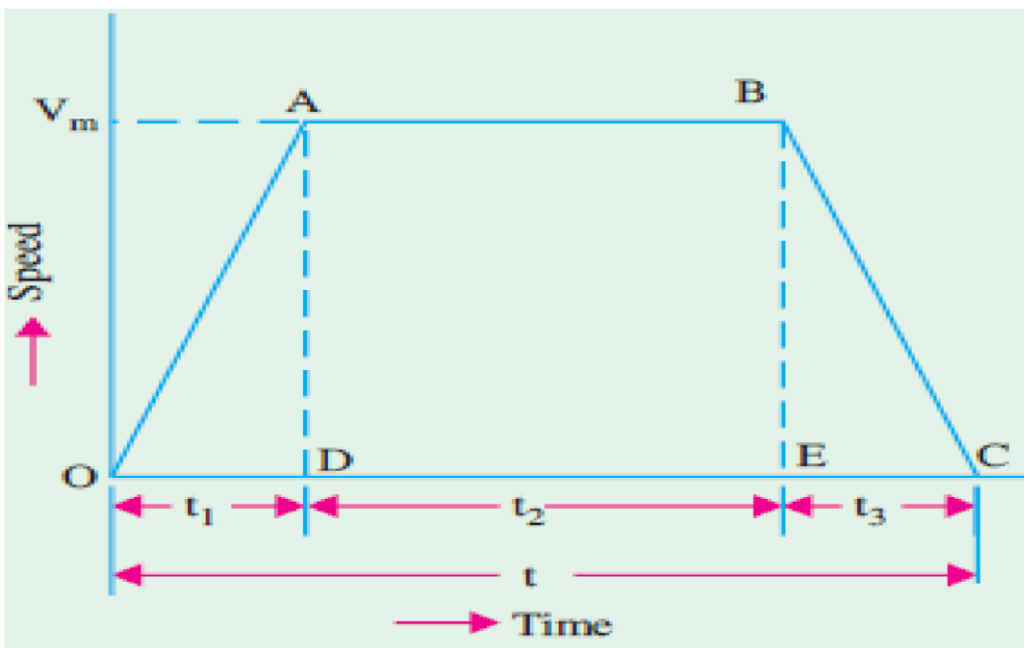

Fig. 43.11

Relationship Between Principal Quantities in Quadrilateral Diagram

The diagram is shown in Fig. 43.12. Let βc represent the retardation during coasting period. As before,

$$\begin{aligned}
 t_1 &= V_1/\alpha, \quad t_2 = (V_2 - V_1)/\beta_c \quad \text{and} \quad t_3 = V_2/\beta \\
 D &= \text{area } OABC \\
 &= \text{area } OAD + \text{area } ABED + \text{area } BCE \\
 &= \frac{1}{2} V_1 t_1 + t_2 \left(\frac{V_1 + V_2}{2} \right) + \frac{1}{2} V_2 t_3 \\
 &= \frac{1}{2} V_1 (t_1 + t_2) + \frac{1}{2} V_2 (t_2 + t_3) \\
 &= \frac{1}{2} V_1 (t - t_3) + \frac{1}{2} V_2 (t - t_1) \\
 &= \frac{1}{2} t (V_1 + V_2) - \frac{V_1 t_1}{2} - \frac{V_2 t_3}{2} \\
 &= \frac{1}{2} t (V_1 + V_2) - \frac{1}{2} V_1 V_2 \left(\frac{1}{\alpha} + \frac{1}{\beta} \right) \\
 &= \frac{1}{2} t (V_1 + V_2) - KV_1 V_2
 \end{aligned}$$

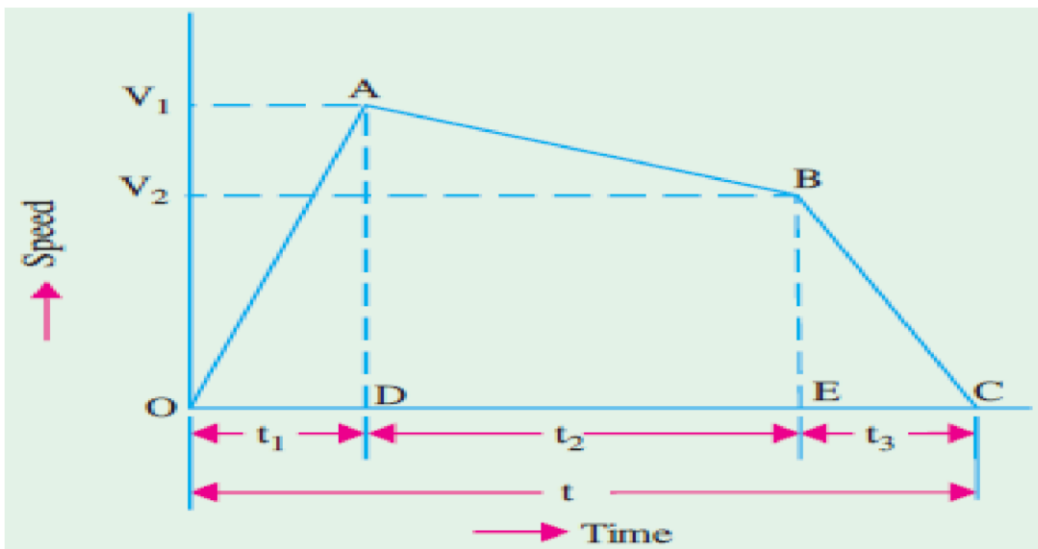

Fig. 43.12

$$\text{where } K = \frac{1}{2} \left(\frac{1}{\alpha} + \frac{1}{\beta} \right) = \frac{\alpha + \beta}{2\alpha\beta} \quad \text{Also, } \beta_c = \frac{(V_1 - V_2)}{t_2}$$

$$\begin{aligned} \therefore V_2 &= V_1 - \beta_c t_2 = V_1 - \beta_c (t - t_1 - t_3) \\ &= V_1 - \beta_c \left(t - \frac{V_1}{\alpha} - \frac{V_2}{\beta} \right) = V_1 \beta_c \left(t - \frac{V_1}{\alpha} \right) + \beta_c \frac{V_2}{\beta} \end{aligned}$$

$$\text{or } V_2 \left(1 - \frac{\beta_c}{\beta} \right) = V_1 - \beta_c \left(t - \frac{V_1}{\alpha} \right) \quad \therefore V_2 = \frac{V_1 - \beta_c (t - V_1/\alpha)}{(1 - \beta_c/\beta)}$$

Tractive Effort for Propulsion of a Train

The tractive effort (Ft) is the force developed by the traction unit at the rim of the driving wheels for moving the unit itself and its train (trailing load). The tractive effort required for train propulsion on a *level track* is

$$Ft = Fa + Fr$$

If gradients are involved, the above expression becomes

$$Ft = Fa + Fg + Fr \text{ — for ascending gradient} = Fa -$$

$$Fg + Fr \text{ — for descending gradient}$$

where Fa = force required for giving linear acceleration to the train

Fg = force required to overcome the effect of gravity

Fr = force required to overcome resistance to train motion.

(a) Value of Fa

If M is the dead (or stationary) mass of the train and a its linear acceleration, then

$$Fa = Ma$$

Since a train has rotating parts like wheels, axles, motor armatures and gearing etc., its *effective* (or accelerating) mass Me is more (about 8 – 15%) than its stationary mass.

These parts have to be given angular acceleration at the same time as the whole train is accelerated in the linear direction.

Hence, $Fe = Mea$

(ii) If Me is in tonne and a in km/h/s, then converting them into absolute units, we have
 $Fa = (1000 Me) \times (1000/3600) a = 277.8 Me a$ newton

(b) Value of F_g

As seen from Fig. 43.13, $F_g = W \sin \theta = Mg \sin \theta$

In railway practice, gradient is expressed as the rise (in metres) a track distance of 100 m and is called percentage gradient.

Therefore % $G = 100/100$

BC/BC

$AC/AC = 100 \sin \theta$ Substituting the value of $\sin \theta$ in the above equation, we

Get $F_g = Mg G/100 = 9.8 \times 10^{-2} MG$

(i) When M is in kg, $F_g = 9.8 \times 10^{-2} MG$ newton

(ii) When M is given in tonne, then

$F_g = 9.8 \times 10^{-2} (1000 M) G = 98 MG$ Newton

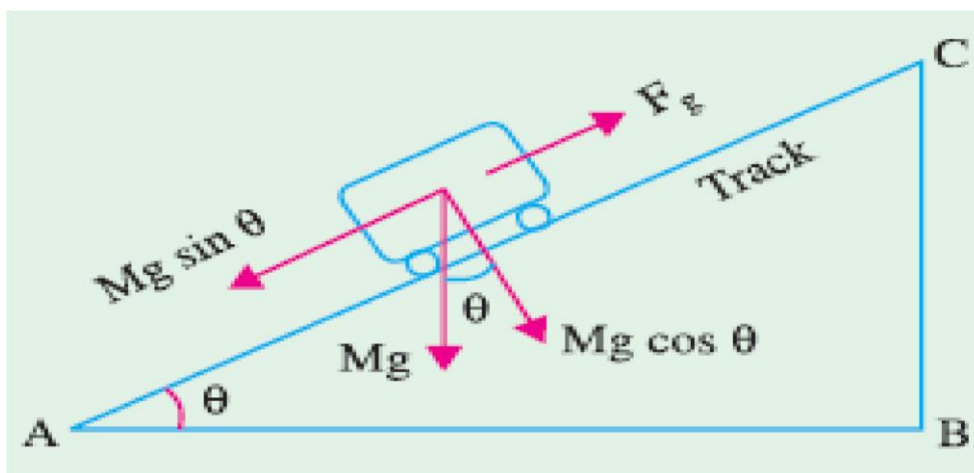

Fig. 43.13

Value of F_r

Train resistance comprises all those forces which oppose its motion. It consists of mechanical resistance and wind resistance. Mechanical resistance itself is made up of internal and external resistances. The internal resistance comprises friction at journals, axles, guides and buffers etc. The external resistance consists of friction between wheels and rails and flange friction etc. Mechanical resistance is almost independent of train speed but depends on its weight. The wind friction varies directly as the square of the train speed. If r is specific resistance of the train *i.e.* resistance offered per unit mass of the train, then $F_r = M.r$.

(i) If r is in newton per kg of train mass and M is the train mass in kg, then

$$Fr = M.r \text{ newton}$$

(ii) If r is in newton per tonne train mass (N/t) and M is in tonne (t), then

$$Fr = M \text{ tonne} \times r = Mr \text{ newton}^*$$

Hence, expression for total tractive effort becomes

$$Ft = Fa \pm Fg + Fr = (277.8 \alpha Me \pm 98 MG + Mr) \text{ newton}$$

Please remember that here M is in tonne, α in km/h/s, G is in metres per 100 m of track length (*i.e.* % G) and r is in newton/tonne (N/t) of train mass.

The positive sign for Fg is taken when motion is along an ascending gradient and negative sign when motion is along a descending gradient.

Power Output from Driving Axles

If Ft is the tractive effort and v is the train velocity, then output power = $Ft \times v$

(i) If Ft is in newton and v in m/s, then output power = $Ft \times v$ watt

(ii) If Ft is in newton and v is in km/h, then converting v into m/s, we have **Fig. 43.13**

* If r is in kg (wt) per tonne train mass and M is in tonne, then $Fr = M \text{ tonne} \times (r \times 9.8) \text{ newton/tonne} = 9.8$

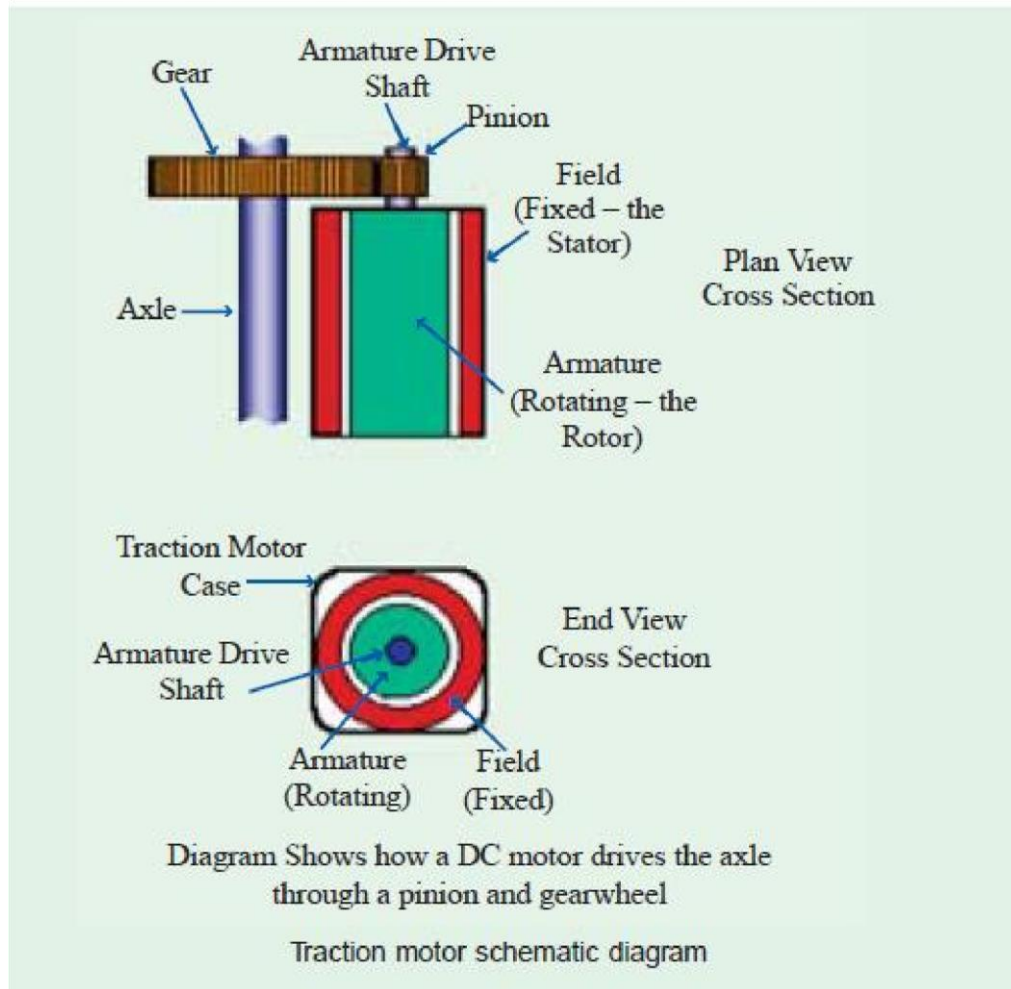

$$\text{output power} = F_t \times \left(\frac{1000}{3600}\right) v \text{ watt} = \frac{F_t v}{3600} \text{ kW}$$

If η is the efficiency of transmission gear, then power output of motors is

$$= F_t \cdot v / \eta \text{ watt} \quad \text{--- } v \text{ in m/s}$$

$$= \frac{F_t v}{3600 \eta} \text{ kW} \quad \text{--- } v \text{ in km/h}$$

Energy Output from Driving Axles

Energy (like work) is given by the product of power and time. $E = (F_t \times v) \times t = F_t \times (v \times t) = F_t \times D$ where D is the distance travelled in the direction of tractive effort.

Total energy output from driving axles for the run is

E = energy during acceleration + energy during free run

As seen from Fig. 43.11

$E = Ft \times \text{area } OAD + Ft' \times \text{area } ABED = Ft \times 1/2Vm t_1 + Ft' \times 1/2Vm t_2$ where Ft is the tractive effort during accelerating period and Ft' that during free running period. Incidentally, Ft will consist of all the three components given in Art. 43.37 whereas Ft' will consist of $(98 MG + Mr)$ provided there is an ascending gradient.

Specific Energy Output

It is the energy output of the driving wheel expressed in watt-hour (Wh) per tonne-km (t -km) of the train. It can be found by first converting the energy output into Wh and then dividing it by the mass of the train in tonne and route distance in km.

Hence, unit of specific energy output generally used in railway work is : Wh/tonne-km (Wh/t-km).

Evaluation of Specific Energy Output

We will first calculate the total energy output of the driving axles and then divide it by train mass in tonne and route length in km to find the specific energy output. It will be presumed that :

- (i) there is a gradient of G throughout the run and
- (ii) power remains ON upto the end of free run in the case of trapezoidal curve and upto the accelerating period in the case of quadrilateral curve

Now, output of the driving axles is used for the following purposes :

1. for accelerating the train
2. for overcoming the gradient
3. for overcoming train resistance.

(a) Energy required for train acceleration (Ea)

As seen from trapezoidal diagram

$$\begin{aligned}
 E_a &= F_a \times \text{distance } OAD = 277.8 \alpha M_e \times \frac{1}{2} V_m t_1 \text{ joules} \\
 &= 277.8 \alpha M_e \times \frac{1}{2} V_m \times \frac{V_m}{\alpha} \text{ joules} \quad \left(\overline{V} t_1 = \frac{V_m}{\alpha} \right) \\
 &= 277.8 \alpha M_e \times \left[\frac{1}{2} \cdot \frac{V_m \times 1000}{3600} \times \frac{V_m}{\alpha} \right] \text{ joules}
 \end{aligned}$$

It will be seen that since V_m is in km/h, it has been converted into m/s by multiplying it with the conversion factor of (1000/3600). In the case of (V_m / t) , conversion factors for V_m and t being the same, they cancel out. Since 1 Wh = 3600 J.

$$\therefore E_a = 277.8 \alpha M_e \left[\frac{1}{2} \cdot \frac{V_m \times 1000}{3600} \times \frac{V_m}{\alpha} \right] \text{ Wh} = 0.01072 \frac{V_m^2}{M_e} \text{ Wh}$$

(b) Energy required for overcoming gradient (E_g)

$$E_g = F_g \times D'$$

where ' D' ' is the *total distance over which power remains ON*. Its maximum value equals the distance represented by the area $OABE$ in Fig. 43.11 *i.e.* from the start to the end of free-running period in the case of trapezoidal curve [as per assumption (i) above].

Substituting the value of F_g from Art. 43.37, we get

$$E_g = 98 \text{ MG} \cdot (1000 D') \text{ joules} = 98,000 \text{ MGD}' \text{ joules}$$

It has been assumed that D' is in km.

When expressed in Wh, it becomes

$$E_g = 98,000 \text{ MGD}' \frac{1}{3600} \text{ Wh} = 27.25 \text{ MGD}' \text{ Wh}$$

(c) Energy required for overcoming resistance (E_r)

$$\begin{aligned}
 E_r &= F_r \times D' = M \cdot r \times (1000 D') \text{ joules} && \text{--- } D' \text{ in km} \\
 &= \frac{1000 Mr D'}{3600} \text{ Wh} = 0.2778 Mr D' \text{ Wh} && \text{--- } D' \text{ in km}
 \end{aligned}$$

\therefore total energy output of the driving axles is

$$E = E_a + E_g + E_r$$

$$= (0.01072 V_m^2 / M_e + 27.25 MGD' + 0.2778 Mr D' \text{ Wh}$$

Specific energy output

$$E_{spo} = \frac{E}{M \times D} \quad \text{--- } D \text{ is the total run length}$$

$$= \left(0.01072 \frac{V_m^2}{D} \cdot \frac{M_e}{M} + 27.25 G \frac{D'}{D} + 0.2778 r \frac{D'}{D} \right) \text{Wh/t-km}$$

It may be noted that if there is no gradient, then

$$E_{spo} = \left(0.01072 \frac{V_m^2}{D} \cdot \frac{M_e}{M} + 0.2778 r \frac{D'}{D} \right) \text{Wh/t-km}$$

Alternative Method

As before, we will consider the trapezoidal speed/time curve. Now, we will calculate energy output not **force-wise** but **period-wise**.

(i) Energy output during accelerating period

$$E_a = F_t \times \text{distance travelled during accelerating period}$$

$$= F_t \times \text{area } OAD \quad \text{---Fig. 43.11}$$

$$= F_t \times \frac{1}{2} V_m t_1 = \frac{1}{2} F_t \cdot V_m \cdot \frac{V_m}{\alpha}$$

$$= \frac{1}{2} \cdot F_t \left(\frac{1000}{3600} \cdot V_m \right) \cdot \frac{V_m}{\alpha} \text{ joules}$$

$$= \frac{1}{2} \cdot F_t \left(\frac{1000}{3600} \cdot V_m \right) \cdot \frac{V_m}{\alpha} \cdot \frac{1}{3600} \text{ Wh}$$

Substituting the value of F_t , we get

$$E_a = \frac{1000}{(3600)^2} \cdot \frac{V_m^2}{2\alpha} (277.8 \alpha M_e + 98 MG + Mr) \text{ Wh}$$

It must be remembered that during this period, **all the three forces are at work** (Art. 43.37)

(ii) Energy output during free-running period

Here, work is required only against two forces *i.e.* gravity and resistance (as mentioned earlier).

Energy $E_{fr} = F'_t \times \text{area } ABED \quad \text{---Fig. 43.11}$

$$= F'_t \times (V_m \times t_2) = F'_t \times \left(\frac{1000}{3600} V_m \right) \cdot t_2 \text{ joules}$$

$$= F'_t \times \left(\frac{1000}{3600} V_m \right) \times t_2 \times \frac{1}{3600} \text{ Wh} = \left(\frac{1000}{3600} \right) F'_t \times V_m t_2 \cdot \frac{1}{3600} \text{ Wh}$$

$$= \left(\frac{1000}{3600} \right) \cdot F'_t \times D_{fr} \text{ Wh} = \left(\frac{1000}{3600} \right) (98 MG + Mr) D_{fr} \text{ Wh}$$

where D_{fr} is the distance in km travelled during the free-running period*

Total energy required is the sum of the above two energies.

$$\therefore E = E_a + E_{fr}$$

$$= \frac{1000}{(3600)^2} \cdot \frac{V_m^2}{2\alpha} (277.8 \alpha \cdot M_e + 98 MG + Mr) + \frac{1000}{3600} (98 MG + Mr) D_{fr} \text{ Wh}$$

* $D_{fr} = \text{velocity in km/h} \times \text{time in hours}$
 $= V_m \times (t_2 / 3600)$ because times are always taken in seconds.

$$\begin{aligned}
 &= \frac{1000}{(3600)^2} \frac{V_m^2}{2\alpha} 277.8 \alpha M_e + \frac{1000}{(3600)^2} \cdot \frac{V_m^2}{2\alpha} (98 MG + Mr) + \frac{1000}{3600} (98 MG + Mr) \cdot D_{fr} \text{ Wh} \\
 &= 0.01072 V_m^2 \cdot M_e + \frac{1000}{3600} (98 MG + Mr) \left(\frac{V_m^2}{2\alpha \times 3600} + D_{fr} \right) \text{ Wh}
 \end{aligned}$$

Now,
$$\frac{V_m^2}{2\alpha \times 3600} = \frac{1}{2} \left(\frac{V_m}{3600} \right) \cdot \frac{V_m}{\alpha} = \frac{1}{2} \left(\frac{V_m}{3600} \right) \cdot t_1$$

= distance travelled during accelerating period i.e. D_a

$$\begin{aligned}
 \therefore E &= 0.01072 V_m^2 \cdot M_e + \frac{1000}{3600} (98 MG + Mr) (D_a + D_{fr}) \text{ Wh} \\
 &= 0.01072 V_m^2 \cdot M_e + (27.25 MG + 0.2778 Mr) D' \text{ Wh}
 \end{aligned}$$

It is the same expression as found above.

Energy Consumption

It equals the total energy input to the traction motors from the supply. It is usually expressed in Wh which equals 3600 J. It can be found by dividing the energy output of the driving wheels with the combined efficiency of transmission gear and motor.

$$\therefore \text{energy consumption} = \frac{\text{output of driving axles}}{\eta_{motor} \times \eta_{gear}}$$

Specific Energy Consumption

It is the energy consumed (in Wh) per tonne mass of the train per km length of the run. Specific energy consumption,

$$E_{spc} = \frac{\text{total energy consumed in Wh}}{\text{train mass in tonne} \times \text{run length in km}} = \frac{\text{specific energy output}}{\eta}$$

where η = overall efficiency of transmission gear and motor = $\eta_{gear} \times \eta_{motor}$

As seen from Art. 43.41, specific energy consumption is

$$E_{spc} = \left(0.01072 \cdot \frac{V_m^2}{\eta D} \cdot \frac{M_e}{M} + 27.25 \frac{G}{\eta} \cdot \frac{D'}{D} + 0.2778 \frac{r}{\eta} \cdot \frac{D'}{D} \right) \text{Wh/t-km}$$

If no gradient is involved, then specific energy consumption is

$$E_{spc} = \left(0.01072 \cdot \frac{V_m^2}{\eta D} \cdot \frac{M_e}{M} + 0.2778 \frac{r}{\eta} \cdot \frac{D'}{D} \right) \text{Wh/t-km}$$

The specific energy consumption of a train running at a given schedule speed is influenced by

1. Distance between stops
2. Acceleration
3. Retardation
4. Maximum speed
5. Type of train and equipment
6. Track configuration.

Adhesive Weight

It is given by the total weight carried on the driving wheels. Its value is $W_a = x W$, where W is dead weight and x is a fraction varying from 0.6 to 0.8.

Coefficient of Adhesion

Adhesion between two bodies is due to interlocking of the irregularities of their surfaces in contact.

The adhesive weight of a train is **equal to the total weight to be carried on the driving**

wheels. It is less than the dead weight by about 20 to 40%.

If $x = \frac{\text{adhesive weight, } W_a}{\text{dead weight } W}$, then, $W_a = x W$

Let, $F_t =$ tractive effort to slip the wheels
 or
 $=$ maximum tractive effort possible without wheel slip

Coefficient of adhesion, $\mu_a = F_t / W_a$

$\therefore F_t = \mu_a W_a = \mu_a x W = \mu_a x Mg$

If M is in tonne, then

$$F_t = 1000 \times 9.8 \times \mu_a M = 9800 \mu_a \times M \text{ newton}$$

It has been found that tractive effort can be increased by increasing the motor torque but only up to a certain point. Beyond this point, any increase in motor torque does not increase the tractive effort but merely causes the driving wheels to slip. It is seen from the above relation that for increasing F_t , it is not enough to increase the kW rating of the traction motors alone but the weight on the driving wheels has also to be increased.

Adhesion also plays an important role in braking. If braking effort exceeds the adhesive weight of the vehicle, skidding takes place.

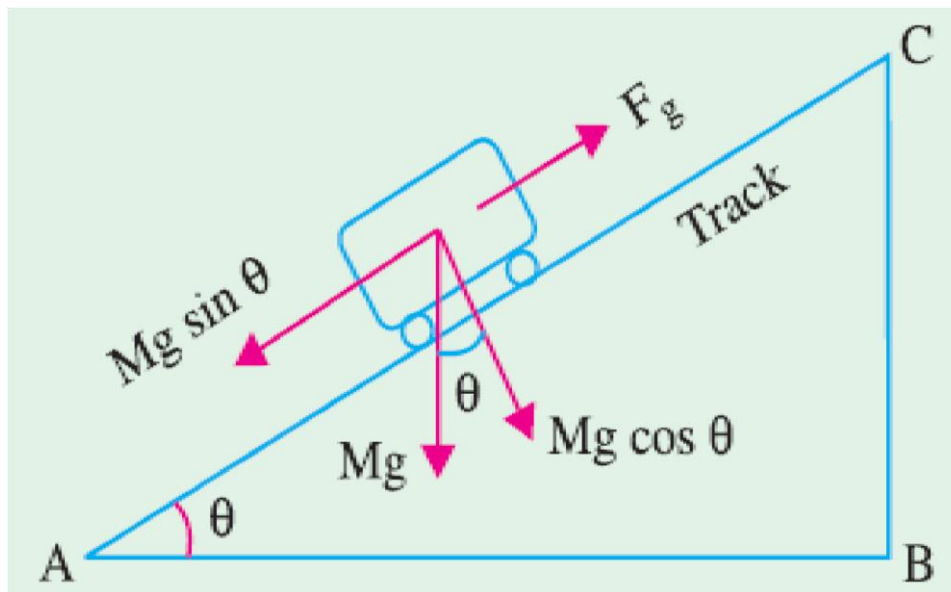

Fig. 43.14

Mechanism of Train Movement

The essentials of driving mechanism in an electric vehicle are illustrated in Fig. 43.14. The armature of the driving motor has a pinion which meshes with the gear wheel keyed to the axle of the driving wheel. In this way, motor torque is transferred to the wheel through the gear.

Let, T = torque exerted by the motor

F_1 = tractive effort at the pinion

F_t = tractive effort at the wheel

γ = gear ratio

Here, d_1, d_2 = diameters of the pinion and gear wheel respectively

D = diameter of the driving wheel

η = efficiency of power transmission from the motor to driving axle

Now, $T = F_1 \times d_1/2$ or $F_1 = 2T/d_1$

Tractive effort transferred to the driving wheel is

$$F_t = \eta F_1 \left(\frac{d_2}{D} \right) = \eta \cdot \frac{2T}{d_1} \left(\frac{d_2}{D} \right) = \eta T \left(\frac{2}{D} \right) \left(\frac{d_2}{d_1} \right) = 2 \gamma \eta \frac{T}{D}$$

For obtaining motion of the train without slipping, $F_t \leq \mu_a Wa$ where μ_a is the coefficient of adhesion (Art. 43.45) and Wa is the adhesive weight.

Control of D.C. Motors

The starting current of motor is limited to its normal rated current by starter during starting. At the instant of switching on the motor, back e.m.f. $E_b = 0$ therefore Supply voltage = $V = IR +$ Voltage drop across R_s .

At any other instant during starting

$V = IR +$ Voltage across $R_s + E_b$

At the end of accelerating period, when total R_s is cut-off $V = E_b + IR$

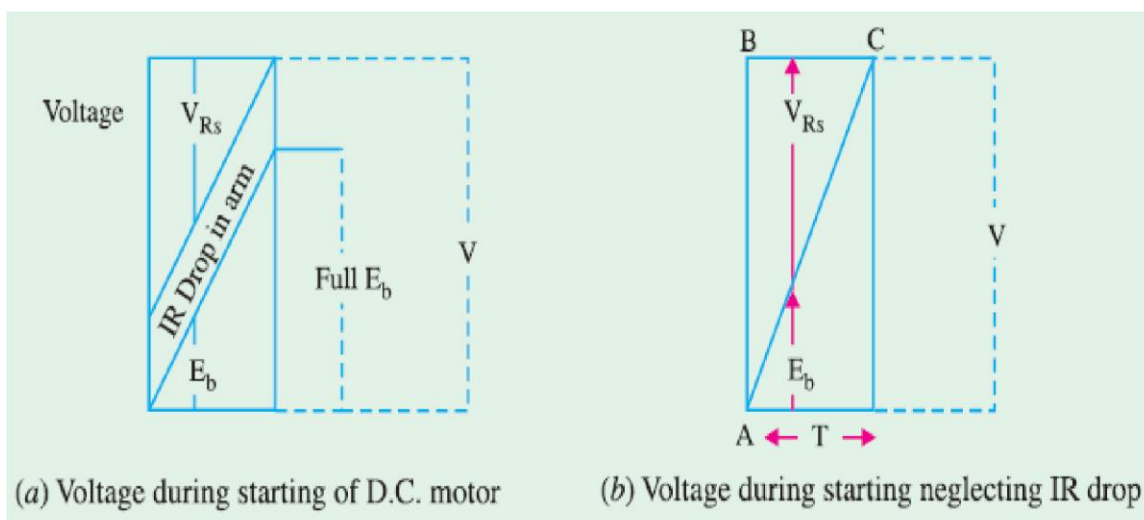

Fig. 43.28

If T is the time in sec. for starting and neglecting IR drop, total energy supplied = $V.IT$. watt-sec

From Fig. 43.28 (b) Energy wasted in $R_s = \text{Area of triangle } ABC \times I = \frac{1}{2} \cdot T.V.I. \text{ watt - sec.} = \frac{1}{2} VIT \text{ watt - sec.}$ But total energy supplied = $V.I.T \text{ watt - sec.}$

Therefore Half the energy is wasted in starting

Therefore $\eta_{\text{starting}} = 50\%$

Series - Parallel Starting

With a 2 motor equipment $\frac{1}{2}$ the normal voltage will be applied to each motor at starting as shown in Fig. 43.29 (a) (Series connection) and they will run upto approximate $\frac{1}{2}$ speed, at which instant they are switched on to parallel and full voltage is applied to each motor. R_s is gradually cutout, with motors in series connection and then reinserted when the motors are connected in parallel, and again gradually cut-out.

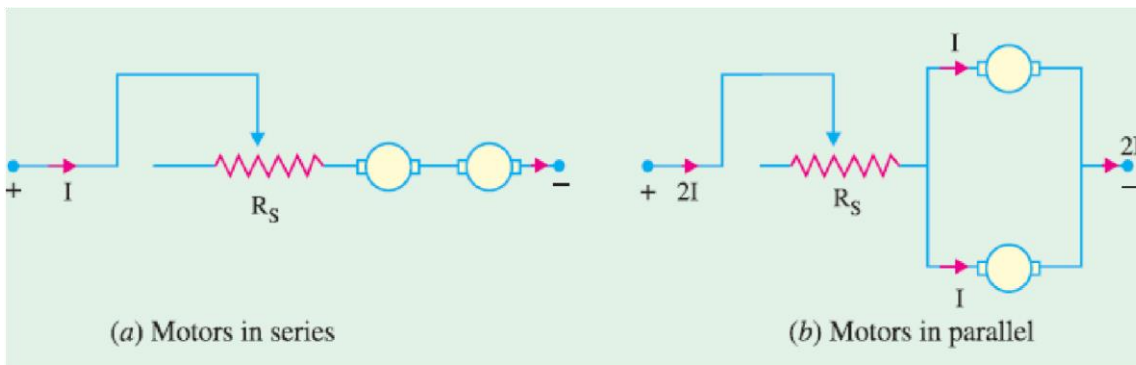

Fig. 43.29

In traction work, 2 or more similar motors are employed. Consider 2 series motors started by series parallel method, which results in saving of energy.

(a) Series operation. The 2 motors, are started in series with the help of R_s . The current during starting is limited to normal rated current I' per motor. During series operation, current I' is drawn from supply. At the instant of starting $OA = AB = IR$ drop in each motor. $OK = \text{Supply voltage } V$. The back e.m.fs. of 2 motors jointly develop along OM as shown in Fig. 43.30 (a). At point, E , supply voltage $V = \text{Back e.m.fs. of 2 motors} + IR \text{ drops of 2 motor}$. Any point on the line BC represents the sum of Back e.m.fs. of 2 motors + IR drops of 2 motors + Voltage across resistance R_s of 2 motors $OE = \text{time taken for series running}$.

At pt E at the end of series running period, each motor has developed a back e.m.f. $= 2V - IR$

$$EL = ED - LD$$

(b) Parallel operation. The motors are switched on in parallel at the instant $\underline{E'}$, with R_s reinserted as shown in Fig. 43.29 (b). Current drawn is $2I$ from supply. Back e.m.f. across each motor = EL . So the back e.m.f. now develops along LG . At point $\underline{H'}$ when the motors are in full parallel, ($R_s = 0$ and both the motors are running at rated speed)

Supply voltage = $V = HF = HG + GF =$ Normal Back e.m.f. of each motor + IR drop in each motor.

To find t_s , t_p and η of starting The values of time t_s during which the motors remain in series and t_p during which they are in parallel can be determined from Fig. 43.30 (a), (c). From Fig. 43.30 (a),

triangles OLE and OGH are similar

$$\therefore \frac{OE}{OH} = \frac{LE}{GH} \therefore \frac{t_s}{T} = \frac{DE - DL}{FH - FG} = \frac{V/2 - IR}{V - IR}$$

$$\therefore t_s = \frac{1}{2} \left(\frac{V - 2IR}{V - IR} \right) T$$

$$t_p = T - t_s = T - \left\{ \frac{1}{2} \left(\frac{V - 2IR}{V - IR} \right) T \right\}$$

$$t_p = T \left\{ 1 - \frac{1}{2} \left(\frac{V - 2IR}{V - IR} \right) \right\}$$

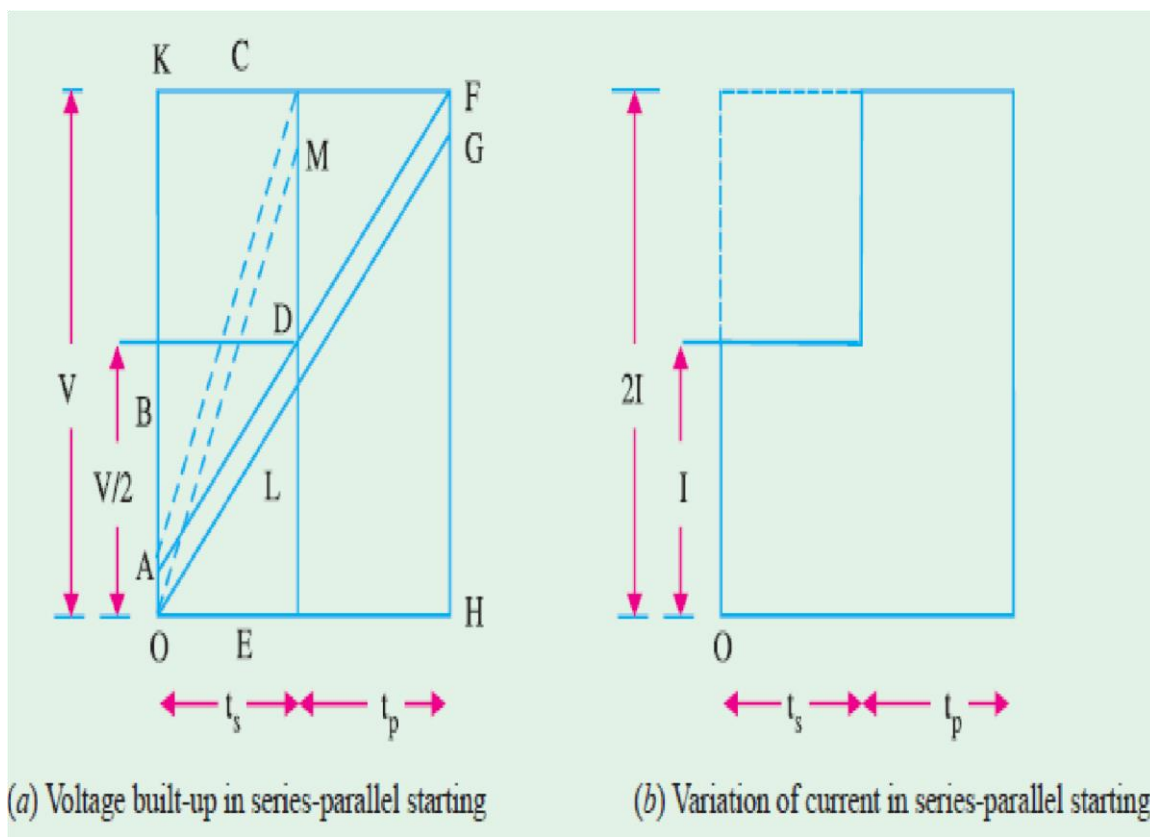

Fig. 43.30

To calculate \square of starting, neglect IR drop in armature circuit.

This modifies Fig. 43.30 (a) to Fig. 43.30 (c). D' is midpoint of CE and back e.m.f. develops along DF in parallel combination. $KC = CF$ i.e. time for series combination = time for parallel combination

i.e. $t_s = t_p = t$ and average starting current = I per motor.

But total energy supplied

$$= IVt + 2IVt \text{ (Series) (Parallel)} = 3VIt$$

$$\begin{aligned} \therefore \eta \text{ of starting} &= \frac{3VIt - VIt}{3VIt} \\ &= \frac{2}{3} = 66.6\% \end{aligned}$$

$\therefore \eta$ is increased by 16.66% as compared to pervious case. If there are 4 motors then $\eta_{\text{starting}} = 73\%$. So there is saving of energy lost in R_s , during starting period as compared with starting by both motors in parallel.

Series Parallel Control by Shunt Transition Method

The various stages involved in this method of series – parallel control are shown in Fig. 43.31 In steps 1, 2, 3, 4 the motors are in series and are accelerated by cutting out the R_s in steps. In step 4, motors are in full series. During transition from series to parallel, R_s is reinserted in circuit– step 5. One of the motors is bypassed -step 6 and disconnected from main circuit – step 7. It is then connected in parallel with other motor -step 8, giving 1st parallel position. R_s is again cut-out in steps completely and the motors are placed in full parallel.

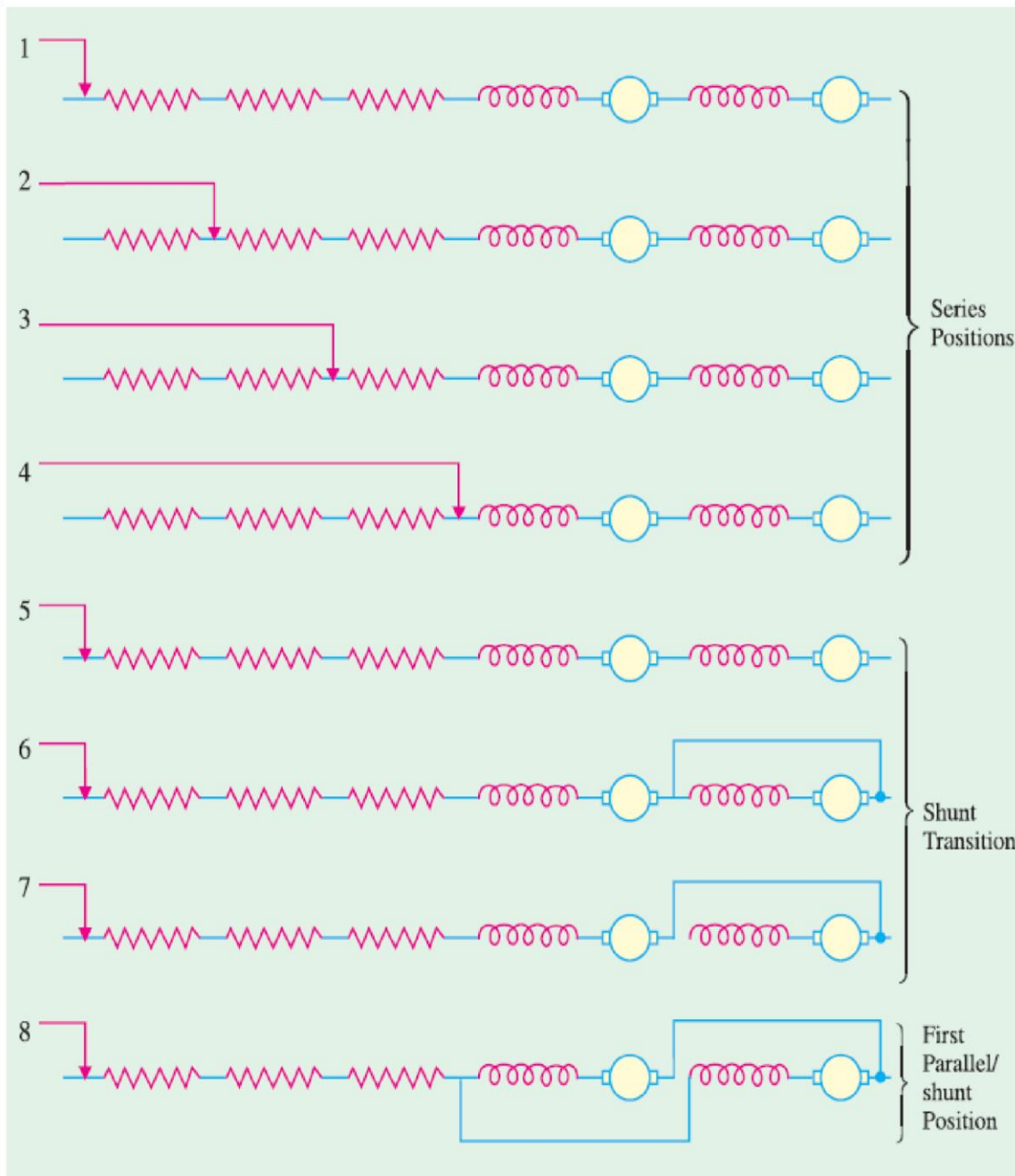

Fig. 43.31

The main difficulty with series parallel control is to obtain a satisfactory method of transition from series to parallel without interrupting the torque or allowing any heavy rushes of current.

In shunt transition method, one motor is short circuited and the total torque is reduced by about 50% during transition period, causing a noticeable jerk in the motion of vehicle. The Bridge transition is more complicated, but the resistances which are connected in parallel with or 'bridged' across the motors are of such a value that current through the motors is not altered in magnitude and the total torque is therefore held constant and hence it is normally used for railways.

So in this method it is seen that, both motors remain in circuit through-out the transition. Thus the jerks will not be experienced if this method is employed.

Series Parallel Control by Bridge Transition

(a) At starting, motors are in series with R_s i.e. link P in position = AA'

(b) Motors in full series with link P in position = BB' (No R_s in the circuit)

The motor and R_s are connected in the form of Wheatstone Bridge. Initially motors are in series with full R_s as shown in Fig. 43.32 (a). A and A' are moved in direction of arrow heads. In position BB' motors are in full series, as shown in Fig. 43.32 (b), with no R_s present in the circuit.

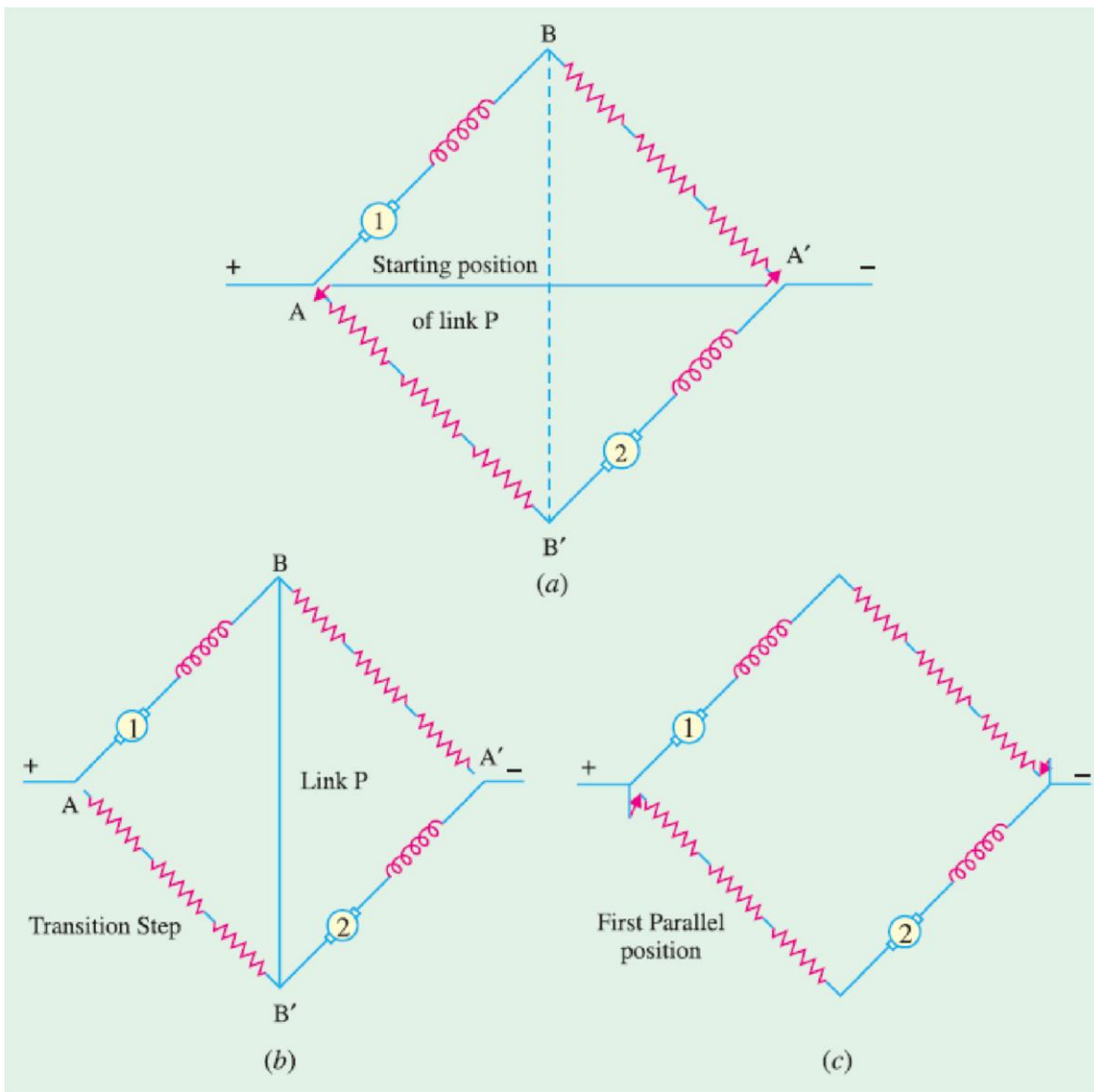

Fig. 43.32

In transition step the R_s is reinserted.

In 1st parallel step, link P is removed and motors are connected in parallel with full R_s as shown in Fig. 43.32 (c). Advantage of this method is that the normal acceleration torque is available from both the motors, through - out starting period. Therefore acceleration is smoother, without any jerks, which is very much desirable for traction motors.

Braking in Traction

Both electrical and mechanical braking is used. Mechanical braking provides holding torque. Electric Braking reduces wear on mechanical brakes, provides higher retardation, thus bringing a vehicle quickly to rest. Different types of electrical braking used in traction are discussed.

Rheostatic Braking

(a) Equalizer Connection (b) Cross Connection

(a) Equalizer Connection

For traction work, where 2 or more motors are employed, these are connected in parallel for braking, because series connection would produce too high voltage. K.E. of the vehicle is utilized in driving the machines as generators, which is dissipated in braking resistance in the form of heat.

To ensure that the 2 machines share the load equally, an equalizer connection is used as shown in Fig. 43.33 (a). If it is not used, the machine whose acceleration builds-up first would send a current through the 2nd machine in opposite direction, causing it to excite with reverse voltage. So that the 2 machines would be short circuited on themselves. The current would be dangerously high. Equalizer prevents such conditions. Hence Equalizer connection is important during braking in traction.

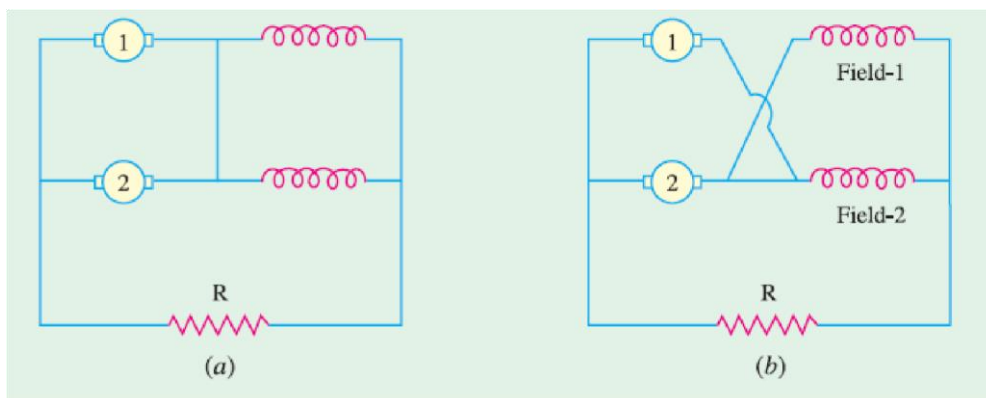

Fig. 43.33

(b) Cross Connection

In cross connection the field of machine 2 is connected in series with armature of machine 1 and the field of machine 1 is connected in series with armature of machine 2 as shown in Fig. 43.33 (b). Suppose the voltage of machine 1 is greater than that of 2. So it will send greater current through field of machine 2, causing it to excite to higher voltage. At the same time machine 1 excitation is low, because of lower voltage of machine 2. Hence machine 2 will produce more voltage and machine 1 voltage will be reduced. Thus automatic compensation is provided and the 2 machines operate satisfactorily.

Because of cross - connection during braking of traction motors, current in any of the motor will not go to a very high value.

Regenerative Braking with D.C. Motors

In order to achieve the regenerative braking, it is essential that (i) the voltage generated by the machine should exceed the supply voltage and (ii) the voltage should be kept at this value, irrespective of machine speed. Fig. 43.34 (a) shows the case of 4 series motors connected in parallel during normal running *i.e.* motoring.

One method of connection during regenerative braking, is to arrange the machines as shunt machines, with series fields of 3 machines connected across the supply in series with suitable resistance. One of the field winding is still kept in series across the 4 parallel armatures as shown in figure 43.34 (b).

The machine acts as a compound generator. (with slight differential compounding) Such an arrangement is quite stable; any change in line voltage produces a change in excitation which produces corresponding change in e.m.f. of motors, so that inherent compensation is provided *e.g.* let the line voltage tends to increase beyond the e.m.f. of generators. The increased voltage across the shunt circuit increases the excitation thereby increasing the generated voltage. Vice-versa is also true. The arrangement is therefore self compensating.

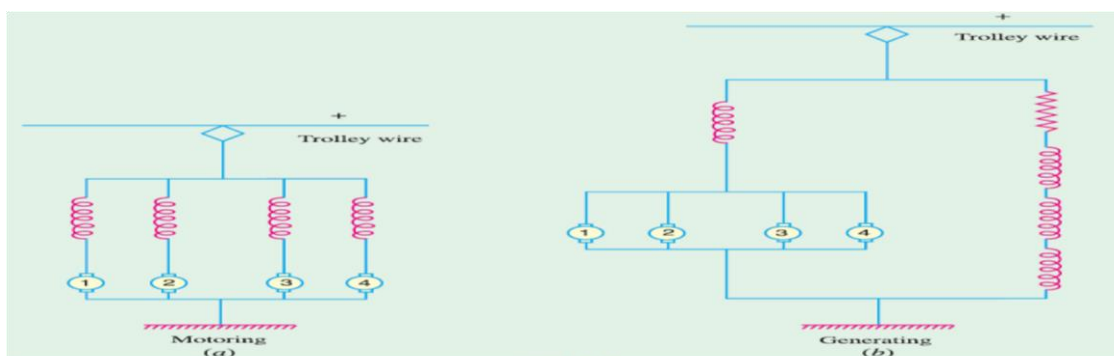

Fig. 43.34

D.C. series motor can't be used for regenerative braking without modification for obvious reasons. During regeneration current through armature reverses; and excitation has to be maintained. Hence field connection must be reversed.

Expected Questions

1. Find the schedule speed of an electric train for a run of 1.5 km if the ratio of its maximum to average speed is 1.25. It has a braking retardation of 3.6 km/h/s, acceleration of 1.8 km/h/s and stop time of 21 second. Assume trapezoidal speed/time curve.
2. A train runs between two stations 1.6 km apart at an average speed of 36 km/h. If the maximum speed is to be limited to 72 km/h, acceleration to 2.7 km/h/s, coasting retardation to 0.18 km/h/s and braking retardation to 3.2 km/h/s, compute the duration of acceleration, coasting and braking periods. Assume a simplified speed/time curve.

3. The peripheral speed of a railway traction motor cannot be allowed to exceed 44 m/s. If gear ratio is 18/75, motor armature diameter 42 cm and wheel diameter 91 cm, calculate the limiting value of the train speed.

4. A 250-tonne motor coach driven by four motors takes 20 seconds to attain a speed of 42 km/h, starting from rest on an ascending gradient of 1 in 80. The gear ratio is 3.5, gear efficiency 92%, wheel diameter 92 cm train resistance 40 N/t and rotational inertia 10 percent of the dead weight. Find the torque developed by each motor.

5. A 250-tonne motor coach having 4 motors, each developing a torque of 8000 N-m during acceleration, starts from rest. If up-gradient is 30 in 1000, gear ratio 3.5, gear transmission efficiency 90%, wheel diameter 90 cm, train resistance 50 N/t, rotational inertia effect 10%, compute the time taken by the coach to attain a speed of 80 km/h.

If supply voltage is 3000 V and motor efficiency 85%, calculate the current taken during the acceleration period.

6. A goods train weighing 500 tonne is to be hauled by a locomotive up an ascending gradient of 2% with an acceleration of 1 km/h/s. If coefficient of adhesion is 0.25, train resistance 40 N/t and effect of rotational inertia 10%, find the weight of locomotive and number of axles if load is not to increase beyond 21 tonne/axle.

7. An electric locomotive weighing 100 tonne can just accelerate a train of 500 tonne (trailing weight) with an acceleration of 1 km/h/s on an up-gradient of 0.1%. Train resistance is 45 N/t and rotational inertia is 10%. If this locomotive is helped by another locomotive of weight 120 tonne, find :

(i) the trailing weight that can now be hauled up the same gradient under the same conditions. (ii) the maximum gradient, if the trailing hauled load remains unchanged. Assume adhesive weight expressed as percentage of total dead weight as 0.8 for both locomotives.

8. The average distance between stops on a level section of a railway is 1.25 km. Motor-coach train weighing 200 tonne has a schedule speed of 30 km/h, the duration of stops being 30 seconds. The acceleration is 1.9 km/h/s and the braking retardation is 3.2 km/h/s. Train resistance to traction is 45 N/t. Allowance for rotational inertia is 10%. Calculate the specific energy output in Wh/t-km. Assume a trapezoidal speed/time curve.

9. A 350-tonne electric train runs up an ascending gradient of 1% with the following speed/time curves :

uniform acceleration of 1.6 km/h/s for 25 seconds. constant speed for 50 seconds 3. coasting for 30 seconds. braking at 2.56 km/h/s to rest.

Compute the specific energy consumption if train resistance is 50 N/t, effect of rotational inertia 10%, overall efficiency of transmission gear and motor, 75%.

10. An ore-carrying train weighing 5000 tonne is to be hauled down a gradient of 1 : 50 at a maximum speed of 30 km/h and started on a level track at an acceleration of 0.29 km/h/s. How many locomotives, each weighing 75 tonne, will have to be employed ? Train resistance during starting = 29.4 N/t, Train resistance at 30 km/h = 49 N/t Coefficient of adhesion = 0.3, Rotational inertia = 10%

11. A 200-tonne electric train runs according to the following quadrilateral speed/ time curve:

1. uniform acceleration from rest at 2 km/h/s for 30 seconds
2. coasting for 50 seconds
3. duration of braking : 15 seconds

If up-gradient is = 1%, train resistance = 40 N/t, rotational inertia effect = 10%, duration of stops = 15 s and overall efficiency of gear and motor = 75%, find

(i) schedule speed (ii) specific energy consumption (iii) how will the value of specific energy consumption change if there is a down-gradient of 1% rather than the up-gradient ?

12. An electric train has an average speed of 45 kmph on a level track between stops 1500 m apart. It is accelerated at 1.8 kmph/s and is braked at 3 kmph/s. Draw the speed – time curve for the run.

13. A train has schedule speed of 60 km per hour between the stops which are 9 km apart. Determine the crest speed over the run, assuming trapezoidal speed – time curve. The train accelerates at 3 kmph/s and retards at 4.5 kmph/s. Duration of stops is 75 seconds.

14. An electric train is to have acceleration and braking retardation of 1.2 km/ hour/sec and 4.8 km/hour/sec respectively. If the ratio of maximum to average speed is 1.6 and time for stops 35 seconds, find schedule speed for a run of 3 km. Assume simplified trapezoidal speedtime curve. 15 An electric train has a schedule speed of 25 kmph between stations 800 m apart. The duration of stop is 20 seconds, the maximum speed is 20 percent higher than the average running speed and the braking retardation is 3 kmph/s. Calculate the rate of acceleration required to operate this service.

16. A suburban electric train has a maximum speed of 80 kmph. The schedule speed including a station stop of 35 seconds is 50 kmph. If the acceleration is 1.5 kmph/s, find the value of retardation when the average distance between stops is 5 km.

17. A train is required to run between two stations 1.6 km apart at the average speed of 40 kmph. The run is to be made to a simplified quadrilateral speed-time curve. If the maximum speed is to be limited to 64 kmph, acceleration to 2.0 kmphs and coasting and braking retardation to 0.16 kmphs and 3.2 kmphs respectively, determine the duration of acceleration, coasting and braking periods.

18. The following figures give the magnetization curve of d.c. series motor when working as a separately excited generator at 600 rpm.:

Field Current (amperes) : 20 40 60 80

E.M.F. (volts) : 215 381 485 550

The total resistance of the motor is 0.8 ohm. Deduce the speed – torque curve for this motor when operating at a constant voltage of 600 volts.

UNIT-8

INTRODUCTION TO ELECTRIC AND HYBRID VEHICLES:

Advantages of Electric Drive

Almost all modern industrial and commercial undertakings employ electric drive in preference to mechanical drive because it possesses the following advantages :

1. It is simple in construction and has less maintenance cost
2. Its speed control is easy and smooth
3. It is neat, clean and free from any smoke or flue gases
4. It can be installed at any desired convenient place thus affording more flexibility in the layout
5. It can be remotely controlled
6. Being compact, it requires less space
7. It can be started immediately without any loss of time
8. It has comparatively longer life.

However, electric drive system has two inherent disadvantages:

1. It comes to stop as soon as there is failure of electric supply and
2. It cannot be used at far off places which are not served by electric supply.

However, the above two disadvantages can be overcome by installing diesel-driven dc generators and turbine-driven 3-phase alternators which can be used either in the absence of or on the failure of normal electric supply.

Classification of Electric Drives

Electric drives may be grouped into three categories : group drive, individual drive and multimotor drive.

In group drive, a single motor drives a number of machines through belts from a common shaft.

It is also called line shaft drive. In the case of an individual drive, each machine is driven by its own separate motor with the help of gears, pulley etc. In multi-motor drives separate motors are provided for actuating different parts of the driven mechanism. For example, in travelling cranes, three motors are used: one for hoisting, another for long travel motion and the third for cross travel motion.

Multimotor drives are commonly used in paper mills, rolling mills, rotary printing presses and metal working machines etc.

Each type of electric drive has its own advantages and disadvantages. The group drive has following advantages :

1. It leads to saving in initial cost because one 150-kW motor costs much less than ten 15-kW motors needed for driving 10 separate machines.
2. Since all ten motors will seldom be required to work simultaneously, a single motor of even 100kW will be sufficient to drive the main shaft. This diversity in load reduces the initial cost still further.
3. Since a single large motor will always run at full-load, it will have higher efficiency and power factor in case it is an induction motor.
4. Group drive can be used with advantage in those industrial processes where there is a sequence of continuity in the operation and where it is desirable to stop these processes simultaneously as in a flour mill.

However, group drive is seldom used these days due to the following disadvantages:

1. Any fault in the driving motor renders all the driven equipment idle. Hence, this system is unreliable.
2. If all the machines driven by the line shaft do not work together, the main motor runs at reduced load. Consequently, it runs with low efficiency and with poor power factor
3. Considerable amount of power is lost in the energy transmitting mechanism.
4. Flexibility of layout of different machines is lost since they have to be so located as to suit the position of the line shaft.
5. The use of line shaft, pulleys and belts etc. makes the drive look quite untidy and less safe to operate.
6. It cannot be used where constant speed is required as in paper and textile industry.
7. Noise level at the worksite is quite high.

Advantages of Individual Drive

It has the following advantages:

1. Since each machine is driven by a separate motor, it can be run and stopped as desired.
2. Machines not required can be shut down and also replaced with a minimum of dislocation.

3. There is flexibility in the installation of different machines.
4. In the case of motor fault, only its connected machine will stop whereas others will continue working undisturbed.
5. The absence of belts and line shafts greatly reduces the risk of accidents to the operating personnel.
6. Each operator has full control of the machine which can be quickly stopped if an accident occurs.
7. Maintenance of line shafts, bearings, pulleys and belts etc. is eliminated. Similarly there is no danger of oil falling on articles being manufactured—something very important in textile industry. The only disadvantage of individual drive is its initial high cost (Ex 44.1). However, the use of individual drives and multimotor drives has led to the introduction of automation in production processes which, apart from increasing the productivity of various undertakings, has increased the reliability and safety of operation.

Selection of a Motor

The selection of a driving motor depends primarily on the conditions under which it has to operate and the type of load it has to handle. Main guiding factors for such a selection are as follows :

(a) Electrical characteristics

1. Starting characteristics
2. Running characteristics
3. Speed control
4. Braking

(b) Mechanical considerations

1. Type of enclosure
2. Type of bearings
3. Method of power transmission
4. Type of cooling
5. Noise level

(c) Size and rating of motors

1. Requirement for continuous, intermittent or variable load cycle
2. Overload capacity

(d) Cost

1. Capital cost
2. Running cost

In addition to the above factors, one has to take into consideration the type of current available whether alternating or direct. However, the basic problem is one of matching the mechanical output of the motor with the load requirement *i.e.* to select a motor with the correct speed/torque characteristics as demanded by the load. In fact, the complete selection process requires the analysis and synthesis of not only the load and the proposed motor but the complete drive assembly and the control equipment which may include rectification or frequency changing.

Types of Enclosures

The main function of an enclosure is to provide protection not only to the working personnel but also to the motor itself against the harmful ingress of dirt, abrasive dust, vapours and liquids and solid foreign bodies such as a spanner or screw driver etc. At the same time, it should not adversely affect the proper cooling of the motor. Hence, different types of enclosures are used for different motors depending upon the environmental conditions. Some of the commonly used motor enclosures are as under:

- 1. Open Type.** In this case, the machine is open at both ends with its rotor being supported on pedestal bearings or end brackets. There is free ventilation since the stator and rotor ends are in free contact with the surrounding air. Such, machines are housed in a separate neat and clean room. This type of enclosure is used for large machines such as d.c. motors and generators.
- 2. Screen Protected Type.** In this case, the enclosure has large openings for free ventilation. However, these openings are fitted with screen covers which safeguard against accidental contacts and rats entering the machine but afford no protection from dirt, dust and falling water. Screen protected type motors are installed where dry and neat conditions prevail without any gases or fumes.
- 3. Drip Proof Type.** This enclosure is used in very damp conditions. *i.e.* for pumping sets. Since motor openings are protected by over-hanging cowls, vertically falling water and dust are not able to enter the machine.
- 4. Splash-proof Type.** In such machines, the ventilating openings are so designed that liquid or dust particles at an angle between vertical and 100° from it cannot enter the machine. Such type of motors can be safely used in rain.
- 5. Totally Enclosed (TE) Type.** In this case, the motor is completely enclosed and no openings are left for ventilation. All the heat generated due to losses is dissipated from the outer surface which is finned to increase the cooling area. Such motors are used for dusty atmosphere *i.e.* sawmills, coalhandling plants and stone-crushing quarries etc.
- 6. Totally-enclosed Fan-cooled (TEFC) Type.** In this case, a fan is mounted on the shaft external to the totally enclosed casing and air is blown over the ribbed outer surfaces of the stator and endshields (Fig. 44.1). Such motors are commonly used in flour mills, cement works and sawmills etc. They require little maintenance apart

from lubrication and are capable of giving years of useful service without any interruption of production.

7. Pipe-ventilated Type. Such an enclosure is used for very dusty surroundings. The motor is totally enclosed but is cooled by neat and clean air brought through a separate pipe from outside the dustladen area. The extra cost of the piping is offset by the use of a smaller size motor on account of better cooling.

8. Flame-proof (FLP) Type. Such motors are employed in atmospheres which contain inflammable gases and vapours *i.e.* in coal mines and chemical plants. They are totally enclosed but their enclosures are so constructed that any explosion within the motor due to any spark does not ignite the gases outside. The maximum operating temperature at the surface of the motor is much less than the ignition temperature of the surrounding gases.

Bearings

These are used for supporting the rotating parts of the machines and are of two types :

1. Ball or roller bearings **2. Sleeve or bush bearings**

(a) Ball Bearings

Upto about 75kW motors, ball bearings are preferred to other bearings because of their following advantages :

1. They have low friction loss
2. They occupy less space
3. They require less maintenance
4. Their use allows much smaller air-gap between the stator and rotor of an induction motor
5. Their life is long.

Their main disadvantages are with regard to cost and noise particularly at high motor speeds.

(b) Sleeve Bearings

These are in the form of self-aligning pourous bronze bushes for fractional kW motors and in the



Fig. 44.1. A three-phase motor

form of journal bearings for larger motors. Since they run very silently, they are fitted on super-silent motors used for driving fans and lifts in offices or other applications where noise must be reduced to the absolute minimum.

Transmission of Power

There are many ways of transmitting mechanical power developed by a motor to the driven machine.

1. Direct Drive. In this case, motor is coupled directly to the driven machine with the help of solid or flexible coupling. Flexible coupling helps in protecting the motor from sudden jerks. Direct drive is nearly 100% efficient and requires minimum space but is used only when speed of the driven machine equals the motor speed.

2. Belt Drive. Flat belts are extensively used for line-shaft drives and can transmit a maximum power of about 250 kW. Where possible, the minimum distance between the pulley centres should be 4 times the diameter of the larger pulley with a maximum ratio between pulley diameters of 6 : 1. The power transmitted by a flat belt increases in proportion to its width and varies greatly with its quality and thickness. There is a slip of 3 to 4 per cent in the belt drive.

3. Rope Drive. In this drive, a number of ropes are run in V-grooves over the pulleys. It has negligible slip and is used when the power to be transmitted is beyond the scope of belt drive.

4. Chain Drive. Though somewhat more expensive, it is more efficient and is capable of transmitting larger amounts of power. is noiseless, slipless and smooth in operation.

5. Gear Drive. It is used when a high-speed motor is to drive a low-speed machine. The coupling between the two is through a suitable ratio gear box. In fact motors for low-speed drives are manufactured with the reduction gear incorporated in the unit itself. Fig. 44.2 shows such a unit

consisting of a flange motor bolted to a high-efficiency gear box which is usually equipped with feet, the motor being overhung.

Noise

The noise produced by a motor could be magnetic noise, wind age noise and mechanical noise. Noise level must be kept to the minimum in order to avoid fatigue to the workers in a workshop. Similarly, motors used for domestic and hospital appliances and in offices and theatres must be almost noiseless. Transmission of noise from the building where the motor is installed to another building can be reduced if motor foundation is flexible *i.e.* has rubber pads and springs.



Fig. 44.2. Geared Motor Unit

Motors for Different Industrial Drives

- 1. D.C. Series Motor.** Since it has high starting torque and variable speed, it is used for heavy duty applications such as electric locomotives, steel rolling mills, hoists, lifts and cranes.
- 2. D.C. Shunt Motor.** It has medium starting torque and a nearly constant speed. Hence, it is used for driving constant-speed line shafts, lathes, vacuum cleaners, wood-working machines, laundry washing machines, elevators, conveyors, grinders and small printing presses etc.
- 3. Cumulative Compound Motor.** It is a varying-speed motor with high starting torque and is used for driving compressors, variable-head centrifugal pumps, rotary presses, circular saws, shearing machines, elevators and continuous conveyors etc.

- 4. Three-phase Synchronous Motor.** Because its speed remains constant under varying loads, it is used for driving continuously- operating equipment at constant speed such as ammonia and air compressors, motor-generator sets, continuous rolling mills, paper and cement industries.
- 5. Squirrel Cage Induction Motor.** This motor is quite simple but rugged and possesses high overload capacity. It has a nearly constant speed and poor starting torque. Hence, it is used for low and medium power drives where speed control is not required as for water pumps, tube wells, lathes, drills, grinders, polishers, wood planers, fans, blowers, laundry washing machines and compressors etc.
- 6. Double Squirrel Cage Motor.** It has high starting torque, large overload capacity and a nearly constant speed. Hence, it is used for driving loads which require high starting torque such as compressor pumps, reciprocating pumps, large refrigerators, crushers, boring mills, textile machinery, cranes, punches and lathes etc.
- 7. Slip-ring Induction Motor.** It has high starting torque and large overload capacity. Its speed can be changed up to 50% of its normal speed. Hence, it is used for those industrial drives which require high starting torque and speed control such as lifts, pumps, winding machines, printing presses, line shafts, elevators and compressors etc.
- 8. Single-phase Synchronous Motor.** Because of its constant speed, it is used in teleprinters, clocks, all kinds of timing devices, recording instruments, sound recording and reproducing systems.
- 9. Single-phase Series Motor.** It possesses high starting torque and its speed can be controlled over a wide range. It is used for driving small domestic appliances like refrigerators and vacuum cleaners etc.
- 10. Repulsion Motor.** It has high starting torque and is capable of wide speed control. Moreover, it has high speed at high loads. Hence, it is used for drives which require large starting torque and adjustable but constant speed as in coil winding machines.
- 11. Capacitor-start Induction-run Motor.** It has fairly constant speed and moderately high starting torque. Speed control is not possible. It is used for compressors, refrigerators and small portable hoists.
- 12. Capacitor-start-and-run Motor.** Its operating characteristics are similar to the above motor except that it has better power factor and higher efficiency. Hence, it is used for drives requiring quiet operations.

Advantages of Electrical Braking Over Mechanical Braking

1. In mechanical braking; due to excessive wear on brake drum, liner etc. it needs frequent and costly replacement. This is not needed in electrical braking and so electrical braking is more economical than mechanical braking.
2. Due to wear and tear of brake liner frequent adjustments are needed thereby making the maintenance costly.
3. Mechanical braking produces metal dust, which can damage bearings. Electrical braking has no such problems.
4. If mechanical brakes are not correctly adjusted it may result in shock loading of machine or machine parts in case of lift, trains which may result in discomfort to the occupants.
5. Electrical braking is smooth. Heavy duty hydraulic motor for high torque and low speeds
6. In mechanical braking the heat is produced at brake liner or brake drum, which may be a source of failure of the brake. In electric braking the heat is produced at convenient place, which in no way is harmful to a braking system.
7. In regenerative braking electrical energy can be returned back to the supply which is not possible in mechanical braking.
8. Noise produced is very high in mechanical braking. Only disadvantage in electrical braking is that it is ineffective in applying holding torque.

Types of Electric Braking

There are three types of electric braking as applicable to electric motors in addition to eddy current braking. These have already been discussed briefly in Art. 44.7.

1. Plugging or reverse-current braking.
2. Rheostatic or dynamic braking.
3. Regenerative braking.

In many cases, provision of an arrangement for stopping a motor and its driven load is as important as starting it. For example, a planning machine must be quickly stopped at the end of its stroke in order to achieve a high rate of production. In other cases, rapid stops are essential for preventing any danger to operator or damage to the product being manufactured. Similarly, in the case of lifts and hoists, effective braking must be provided for their proper functioning.

Plugging Applied to D.C. Motors

As discussed earlier in Art. 42.7, in this case, armature connections are reversed whereas *field winding connections remains unchanged*. With reversed armature connections, the motor develops a torque in the *opposite* direction. When speed reduces to zero, motor will accelerate in the opposite direction. Hence, the arrangement is made to disconnect the motor from the supply as soon as it comes to rest. Fig. 44.3 shows running and reversed connections for shunt motors whereas Fig. 44.4 shows similar conditions for series motors.

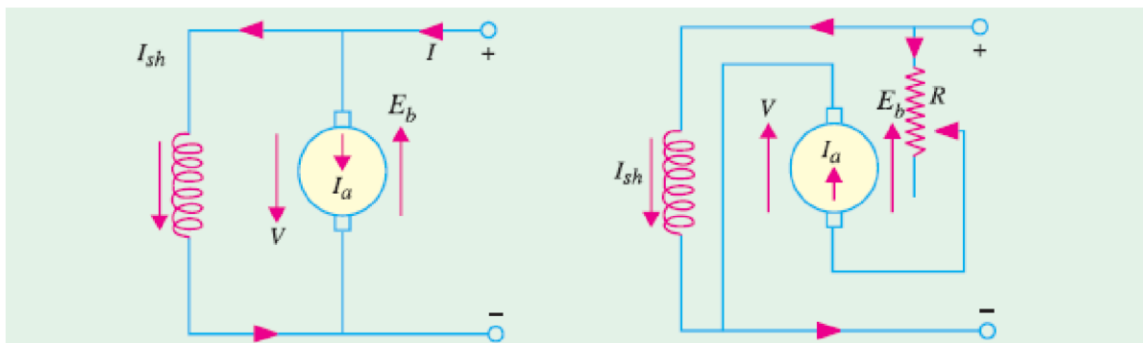

Fig. 44.3

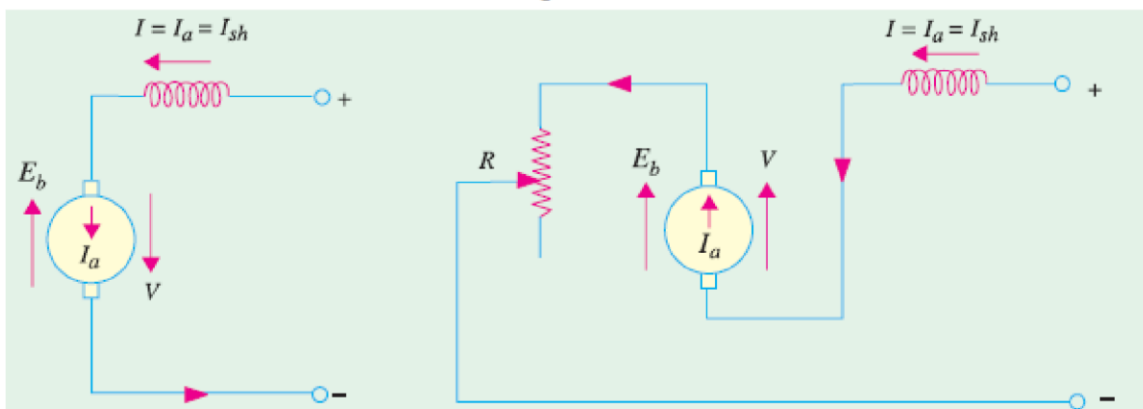

Fig. 44.4

Since with reversed connection, V and E_b are in the same direction, voltage across the armature is almost double of its normal value. In order to avoid excessive current through the armature, additional resistance R is connected in series with armature.

This method of braking is wasteful because in addition to wasting kinetic energy of the moving parts, it draws additional energy from the supply during braking.

Braking Torque. The electric braking torque is given by

$$T_B \propto \Phi I_a = k_1 \Phi I_a; \text{ Now, } I_a = (V + E_b)/R$$

$$\therefore T_B = K_1 \Phi \cdot \frac{V + E_b}{R} = k_1 \Phi \frac{V + k_2 \Phi N}{R} \quad (\because E_b \propto \Phi N)$$

$$= \frac{K_1 \Phi V}{R} + \frac{k_1 k_2 \Phi^2 N}{R} = k_3 \Phi + k_4 \Phi^2 N$$

Shunt Motor

Since in the case, Φ is practically constant, $T_B = k_5 + k_6 N$.

Series Motor

$$T_B = k_3 \Phi + k_4 \Phi^2 N = k_5 I_a + k_6 N I_a^2 \quad (\because \Phi \propto I_a)$$

The value of braking torque can be found with the help of magnetisation curve of a series motor.

Energy Saving in Regenerative Braking

We will now compute the amount of energy recuperated between any two points on a level track during which regenerative braking is employed. The amount of energy thus recovered and then returned to the supply lines depends on :

(i) initial and final velocities of the train during braking (ii) efficiency of the system and (iii) train resistance.

Suppose regenerative braking is applied when train velocity is V_1 km/h and ceases when it is V_2 km/h. If M tonne is the effective mass of the train, then

$$\begin{aligned} \text{K.E. of the train at } V_1 &= \frac{1}{2} M_e V_1^2 = \frac{1}{2} (1000 M_e) \times \left(\frac{1000 V_1}{3600} \right)^2 \text{ joules} \\ &= \frac{1}{2} (1000 M_e) \left(\frac{1000 V_1}{3600} \right)^2 \times \frac{1}{3600} \text{ Wh} \\ &= 0.01072 M_e V_1^2 \text{ Wh} = 0.01072 \frac{M_e}{M} V_1^2 \text{ Wh/tonne} \end{aligned}$$

$$\text{K.E. at } V_2 = 0.01072 \frac{M_e}{M} V_2^2 \text{ Wh/tonne}$$

Hence, energy available for recovery is $= 0.01072 \frac{M_e}{M} (V_1^2 - V_2^2) \text{ Wh/tonne}$

If $r \text{ N/t}$ is the specific resistance of the train, then total resistance $= rM$ newton.

If $d \text{ km}$ is the distance travelled during braking, then

$$\text{energy spent} = rM \times (1000 d) \text{ joules} = rMd \times \frac{1000}{3600} \text{ Wh} = 0.2778 rd \text{ Wh/tonne}$$

Hence, net energy recuperated during regenerative braking is

$$= 0.01072 \frac{M_e}{M} (V_1^2 - V_2^2) - 0.2778 rd \text{ Wh/tonne}$$

Gradient. If there is a *descending* gradient of G per cent over the same distance of $d \text{ km}$, then downward force is $= 98 \text{ MG}$ newton

Energy provided during braking

$$= 98 \text{ MG} \times (1000 d) \text{ joules} = 98 \text{ MG} d (1000 / 3600) \text{ Wh} = 27.25 Gd \text{ Wh/tonne}$$

Hence, net energy recuperated in this case is

$$\begin{aligned} &= \left[0.01072 \frac{M_e}{M} (V_1^2 - V_2^2) - 0.2778 rd + 27.25 Gd \right] \text{ Wh/tonne} \\ &= 0.01072 \frac{M_e}{M} (V_1^2 - V_2^2) + d (27.25 G - 0.2778 r) \text{ Wh/tonne} \end{aligned}$$

If η is the system efficiency, net energy returned to the line is

(i) **level track**

$$= \eta \left[0.01072 \frac{M_e}{M} (V_1^2 - V_2^2) - 0.2778 rd \right] \text{ Wh/tonne}$$

(ii) **descending gradient**

$$= \eta \left[0.01072 \frac{M_e}{M} (V_1^2 - V_2^2) + d (27.25 G - 0.2778 r) \right] \text{ Wh/tonne}$$

Expected Questions

- 1.What are the advantages of Electric drives.
- 2.What are Advantages of Electrical Braking Over Mechanical Braking
- 3.What do you mean by Regenerative Braking
4. How energy is converted to hybrid vehicles through motors
5. What do you mean by hybrid vehicles?
- 6.How hybrid vehicles are nature friendly
- 7.What are motors to be selected for interconnection with hybrid vehicles